

8-line L-C IPAD EMI filter and ESD protection in micro QFN package

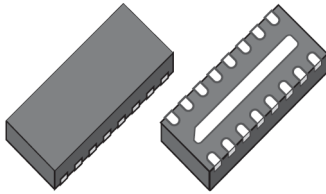

Micro QFN
3.3 x 1.35 16L

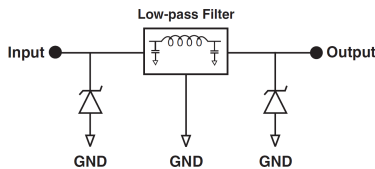

Product status

EMIF08-LCD04M16

Features

- High cut off frequency low-pass filter: $F_C = 400$ MHz at -6 dB
- High efficiency in EMI filtering: better than -35 dB from 900 MHz to 2 GHz
- Very low PCB space consuming with plastic micro-package 3.3 x 1.35 mm
- Very thin package: 0.55 mm max.
- High efficiency in ESD (IEC 61000-4-2 level 4)
- High reliability offered by monolithic integration
- High reduction of parasitic elements through integration and μ QFN packaging
- **ECOPACK2** compliant

Complies with the following standards

- IEC 61000-4-2, level 4 on external pins:
 - ± 15 kV (air discharge)
 - ± 8 kV (contact discharge)

Applications

Where EMI filtering in ESD sensitive equipment is required:

- [Mobile POS](#)
- [Human machine interface \(HMI\): STEVAL-PLC001V1](#)
- [Home automation HMI](#)

Description

The EMIF08-LCD04M16 is an 8-line inductor capacitor (LC) EMI filter designed to suppress EMI/RFI noise in all systems subjected to electromagnetic interferences requiring a large bandwidth.

This filter includes an ESD protection circuitry, which prevents damage to the application when subjected to ESD surges up 15 kV contact discharge.

1 Characteristics

Figure 1. Pin configuration

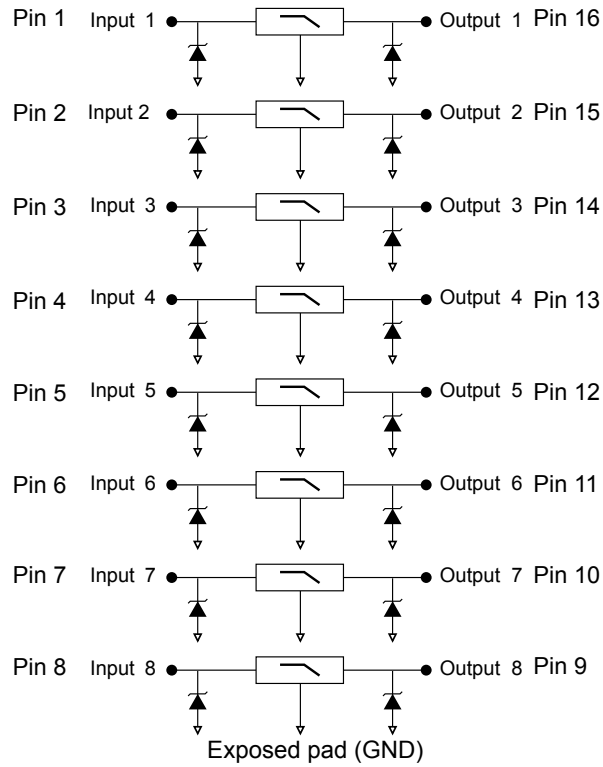
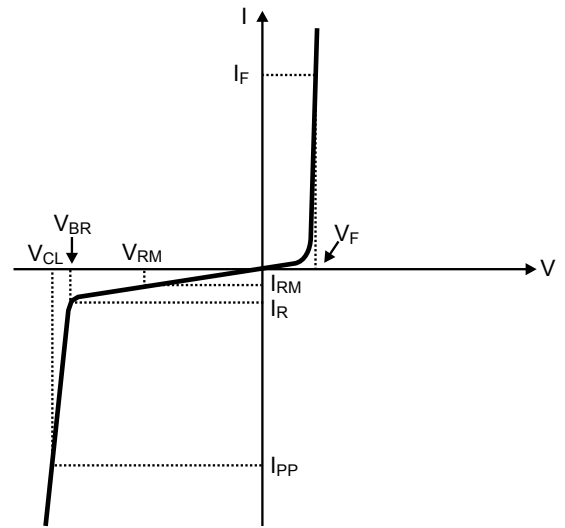

Table 1. Absolute maximum ratings ($T_{amb} = 25\text{ }^{\circ}\text{C}$)

Symbol	Parameter	Value	Unit
V_{PP}	ESD IEC 61000-4-2, contact discharge:	± 15	kV
T_j	Maximum junction temperature	125	$^{\circ}\text{C}$
T_{op}	Operating temperature range	- 40 to + 85	$^{\circ}\text{C}$
T_{stg}	Storage temperature range	- 55 to + 150	$^{\circ}\text{C}$

Figure 2. Electrical characteristics (definitions)

Symbol	Parameter
V_{BR}	Breakdown voltage
I_{RM}	Leakage current at V_{RM}
V_{RM}	Stand-off voltage
V_{CL}	Clamping voltage
R_d	Dynamic resistance
I_{PP}	Peak pulse current
$R_{I/O}$	Series resistance between Input and Output
C_{line}	Input capacitance per line

Table 2. Electrical characteristics ($T_{amb} = 25\text{ }^{\circ}\text{C}$)

Symbol	Test conditions	Min.	Typ.	Max.	Unit
V_{BR}	$I_R = 1\text{ mA}$	6			V
I_{RM}	$V_{RM} = 3\text{ V per line}$			100	nA
L	Inductance		12		nH
R	Parasitic resistance of the inductance	9	12.5	20	Ω
F_C	50 Ω source and 50 Ω load termination at -6 dB		400		MHz
C_{line}	$V_R = 3\text{ V dc}$, $V_{OSC} = 30\text{ mV}$, $F = 1\text{ MHz}$	17	18	19	pF

1.1 Characteristics (curves)

Figure 3. S21 attenuation measurements

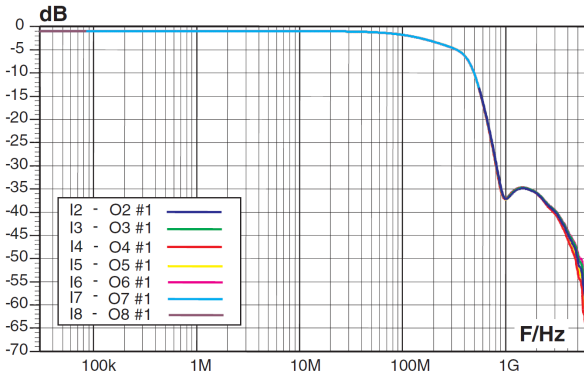

Figure 4. Analog cross talk measurements

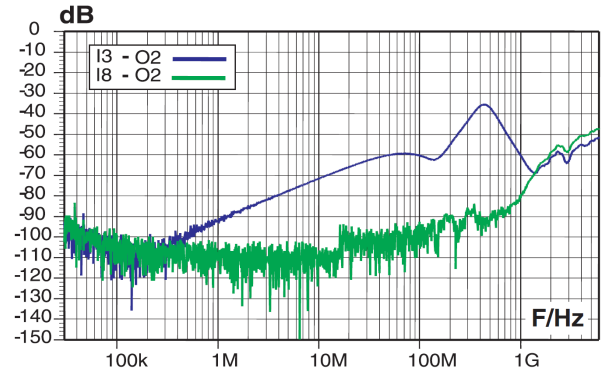

Figure 5. ESD response to IEC 61000-4-2 (+15 kV air discharge)

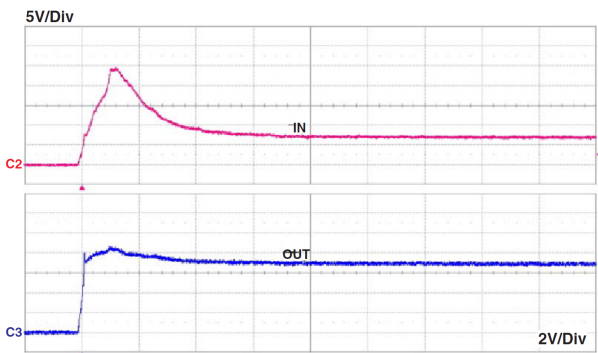

Figure 6. ESD response to IEC 61000-4-2 (-15 kV air discharge)

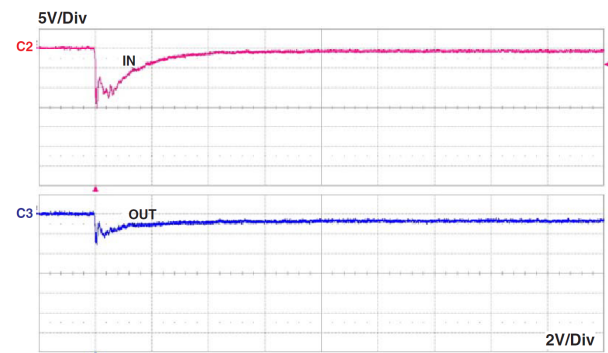
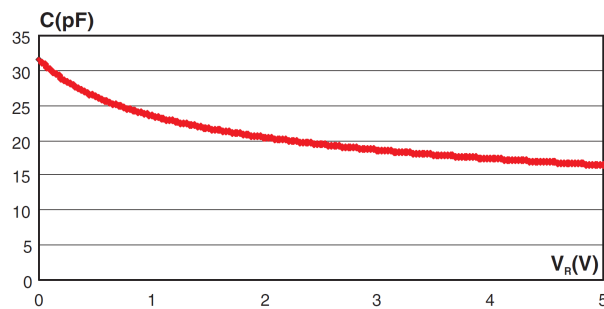

Figure 7. Line capacitance versus applied voltage



2 Package information

In order to meet environmental requirements, ST offers these devices in different grades of **ECOPACK** packages, depending on their level of environmental compliance. ECOPACK specifications, grade definitions and product status are available at: www.st.com. ECOPACK is an ST trademark.

2.1 Micro QFN-16L 3.5x1.35 mm package information

- Epoxy meets UL94, V0
- Lead-free package

Figure 8. Micro QFN-16L 3.5x1.35 mm package outline

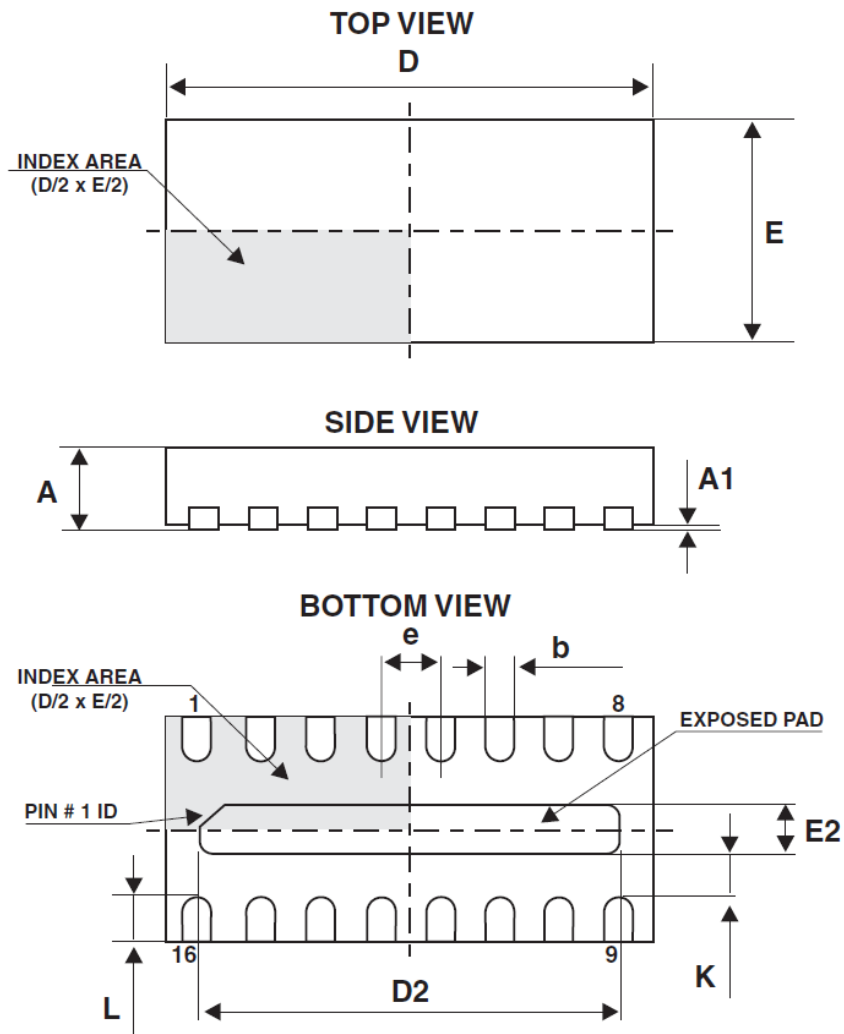
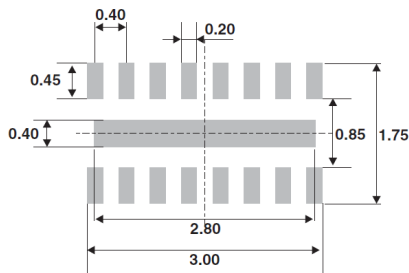
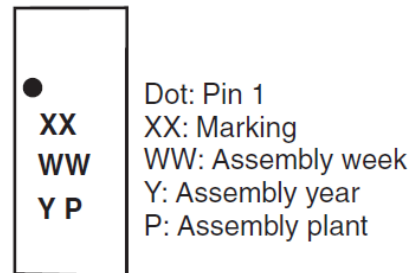

Table 3. Micro QFN-16L 3.5x1.35 mm mechanical data

Ref.	Dimensions					
	Millimeters					
	Min.	Typ.	Max.	Min.	Typ.	Max.
A	0.45	0.50	0.55	0.018	0.020	0.022
A1	0.00	0.02	0.05	0.000	0.0008	0.002
b	0.15	0.20	0.25	0.006	0.008	0.10
D		3.30			0.13	
D2	2.65	2.80	2.90	0.104	0.110	0.114
E		1.35			0.053	
E2	0.25	0.40	0.50	0.010	0.016	0.020
e		0.40			0.016	
k	0.20			0.008		
L	0.15	0.25	0.35	0.006	0.010	0.014

Figure 9. Footprint (dimensions in mm)

Figure 10. Marking

Note: Product marking may be rotated by 90° for assembly plant differentiation. In no case should this product marking be used to orient the component for its placement on a PCB. Only pin 1 mark is to be used for this purpose.

3 Recommendation on PCB assembly

3.1 Stencil opening design

1. General recommendation on stencil opening design
 - a. Stencil opening dimensions: L (Length), W (Width), T (Thickness).
2. General design rule
 - a. Stencil thickness (T) = 75 ~ 125 μm
 - b. Aspect ratio = $\frac{W}{T} \geq 1.5$
 - c. Aspect area = $\frac{L \times W}{2T(L + W)} \geq 0.66$
3. Reference design
 - a. Stencil opening thickness: 100 μm
 - b. Stencil opening for central exposed pad: Opening to footprint ratio is 50%.
 - c. Stencil opening for leads: Opening to footprint ratio is 90%

Figure 11. Stencil opening dimensions

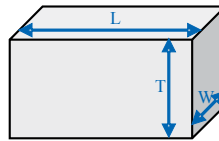
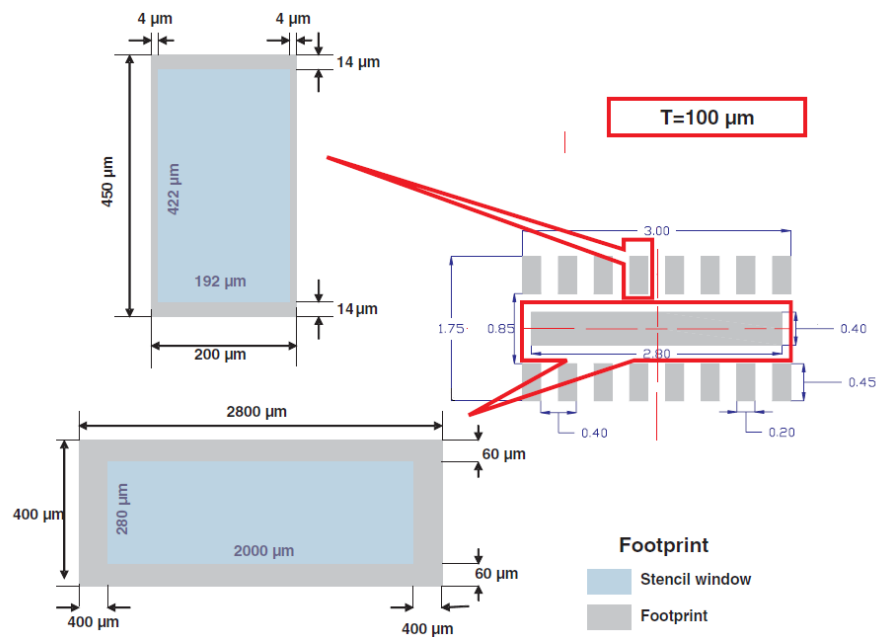

Figure 12. Recommended stencil window position



3.2 Solder paste

1. Halide-free flux qualification ROL0 according to ANSI/J-STD-004.
2. “No clean” solder paste is recommended.
3. Offers a high tack force to resist component movement during high speed.
4. Solder paste with fine particles: powder particle size is 20-45 μm .

3.3 Placement

1. Manual positioning is not recommended.
2. It is recommended to use the lead recognition capabilities of the placement system, not the outline centering
3. Standard tolerance of ± 0.05 mm is recommended.
4. 3.5 N placement force is recommended. Too much placement force can lead to squeezed out solder paste and cause solder joints to short. Too low placement force can lead to insufficient contact between package and solder paste that could cause open solder joints or badly centered packages.
5. To improve the package placement accuracy, a bottom side optical control should be performed with a high resolution tool.
6. For assembly, a perfect supporting of the PCB (all the more on flexible PCB) is recommended during solder paste printing, pick and place and reflow soldering by using optimized tools.

3.4 PCB design preference

1. To control the solder paste amount, the closed via is recommended instead of open vias.
2. The position of tracks and open vias in the solder area should be well balanced. A symmetrical layout is recommended, to avoid any tilt phenomena caused by asymmetrical solder paste due to solder flow away.

3.5 Reflow profile

Figure 13. ST ECOPACK recommended soldering reflow profile for PCB mounting

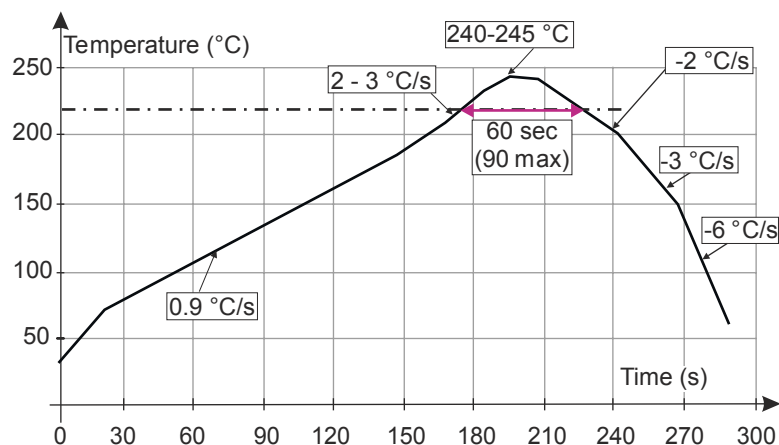

Note: Minimize air convection currents in the reflow oven to avoid component movement.

4 Ordering information

Figure 14. Ordering information scheme

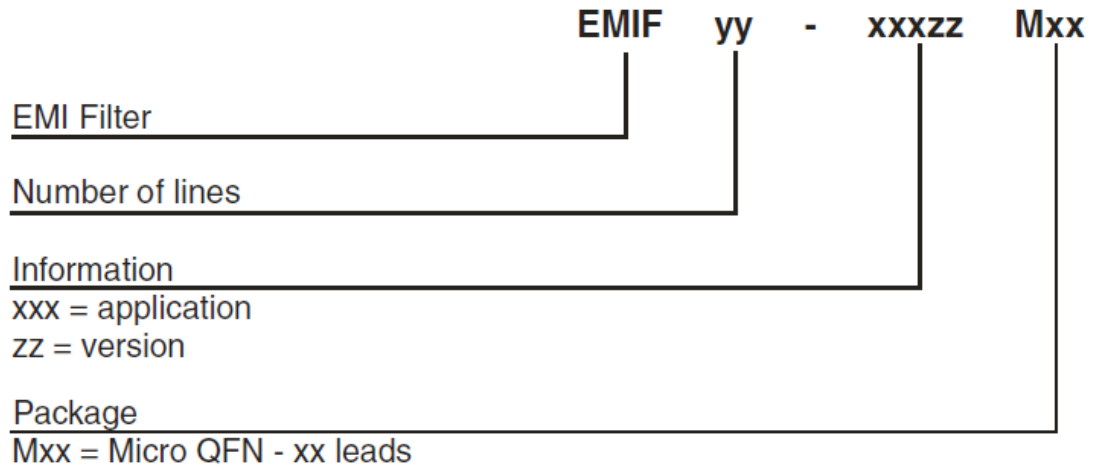

Table 4. Ordering information

Part number	Marking	Package	Weight	Base qty.	Delivery mode
EMIF08-LCD04M16	JA ⁽¹⁾	Micro QFN	6.74 mg	3000	Tape and reel

1. The marking can be rotated by 90° to differentiate assembly location

Revision history

Table 5. Document revision history

Date	Revision	Changes
20-May-2009	1	Initial release.
10-Nov-2009	2	Updated Features on page 1. Added Figure 2 on page 2.
14-Sep-2022	3	Added Figure 1. Pin configuration . Minor text changes.

IMPORTANT NOTICE – READ CAREFULLY

STMicroelectronics NV and its subsidiaries (“ST”) reserve the right to make changes, corrections, enhancements, modifications, and improvements to ST products and/or to this document at any time without notice. Purchasers should obtain the latest relevant information on ST products before placing orders. ST products are sold pursuant to ST’s terms and conditions of sale in place at the time of order acknowledgment.

Purchasers are solely responsible for the choice, selection, and use of ST products and ST assumes no liability for application assistance or the design of purchasers’ products.

No license, express or implied, to any intellectual property right is granted by ST herein.

Resale of ST products with provisions different from the information set forth herein shall void any warranty granted by ST for such product.

ST and the ST logo are trademarks of ST. For additional information about ST trademarks, refer to www.st.com/trademarks. All other product or service names are the property of their respective owners.

Information in this document supersedes and replaces information previously supplied in any prior versions of this document.

© 2022 STMicroelectronics – All rights reserved