

May.1.2023 Copyright 2023 HIROSE ELECTRIC CO., LTD. All Rights Reserved.
In case of consideration for using Automotive equipment / device which demand high reliability, kindly contact our sales window correspondents.

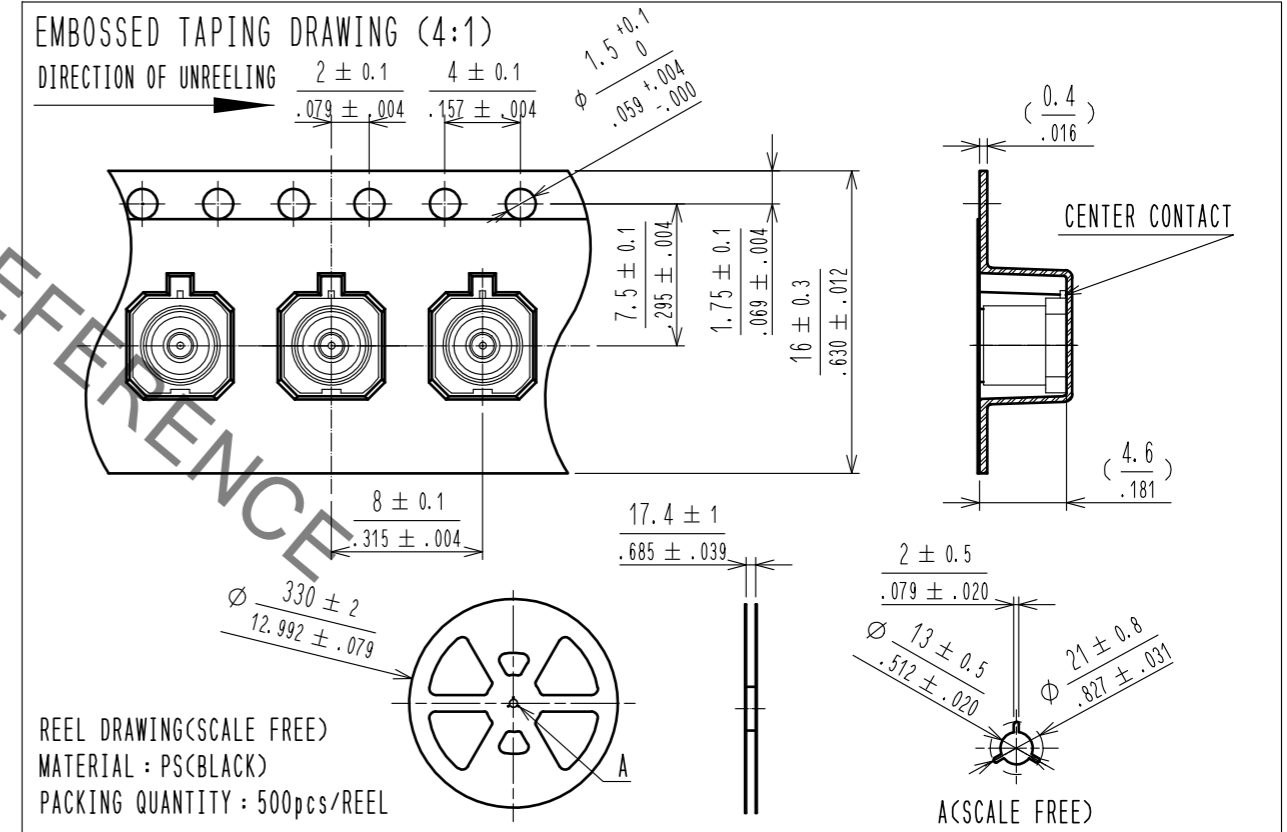
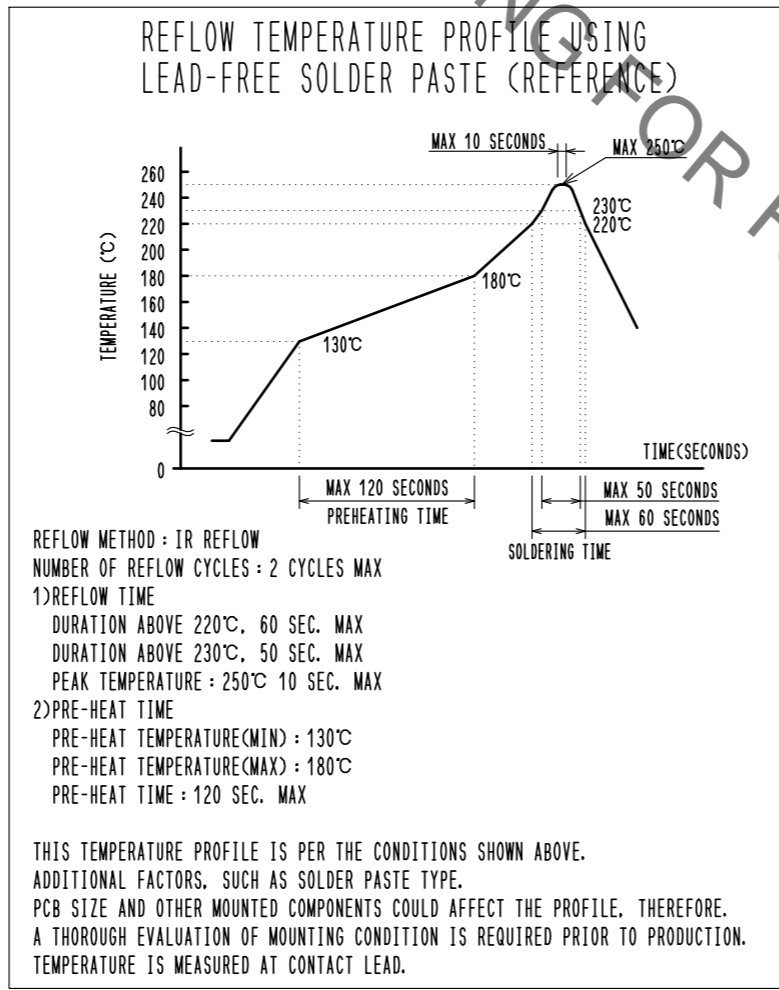
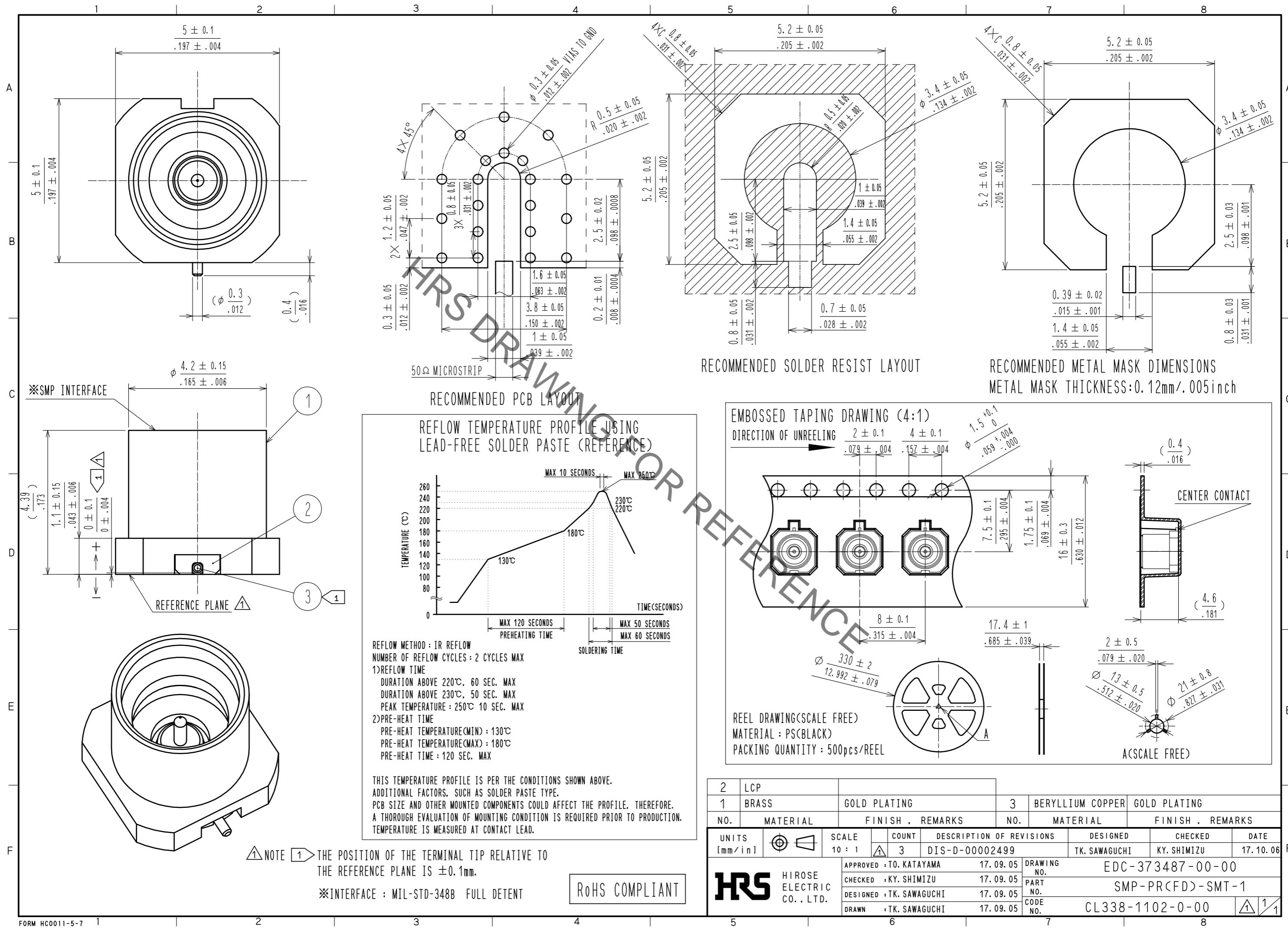

NOTE 1 THE POSITION OF THE TERMINAL TIP RELATIVE TO THE REFERENCE PLANE IS ±0.1mm.

※INTERFACE : MIL-STD-348B FULL DETENT

ROHS COMPLIANT

2	LCP		3	BERYLLIUM COPPER	GOLD PLATING			
1	BRASS	GOLD PLATING						
NO.	MATERIAL	FINISH	REMARKS	NO.	MATERIAL	FINISH	REMARKS	
UNITS [mm/in]		SCALE 10 : 1	COUNT 3	DESCRIPTION OF REVISIONS		DESIGNED TK. SAWAGUCHI	CHECKED KY. SHIMIZU	DATE 17.10.06
APPROVED : TO. KATAYAMA		17.09.05		DRAWING NO.		EDC-373487-00-00		
CHECKED : KY. SHIMIZU		17.09.05		PART NO.		SMP-PR(FD)-SMT-1		
DESIGNED : TK. SAWAGUCHI		17.09.05		CODE NO.		CL338-1102-0-00		
DRAWN : TK. SAWAGUCHI		17.09.05						