

May.1.2023 Copyright 2023 HIROSE ELECTRIC CO., LTD. All Rights Reserved.
In case of consideration for using Automotive equipment / device which demand high reliability, kindly contact our sales window correspondents.

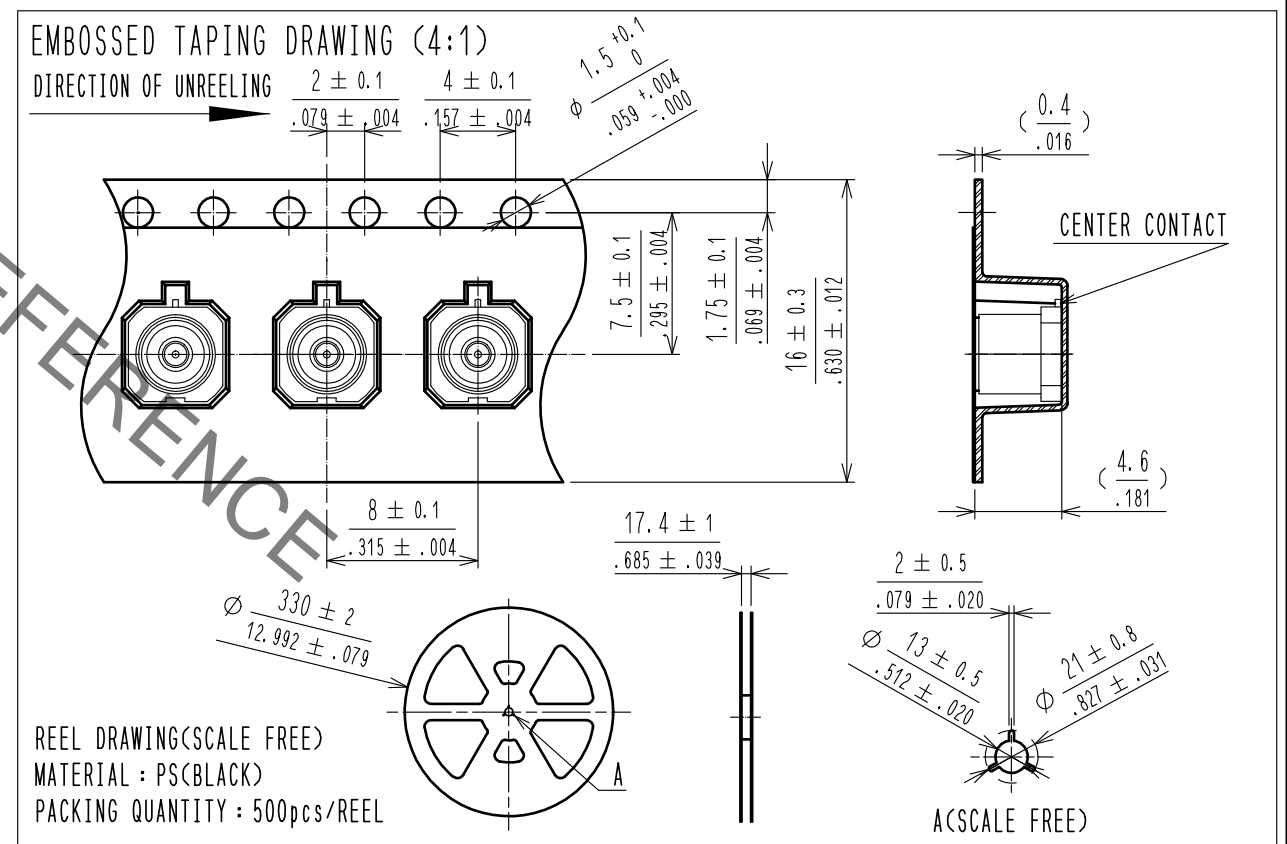
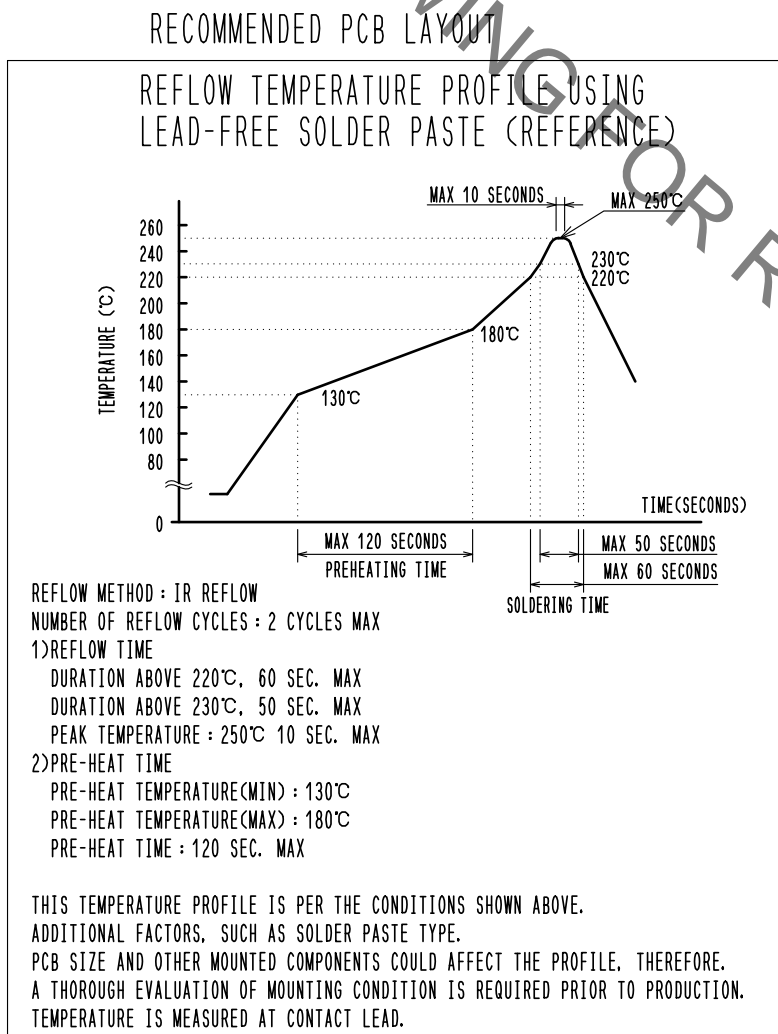
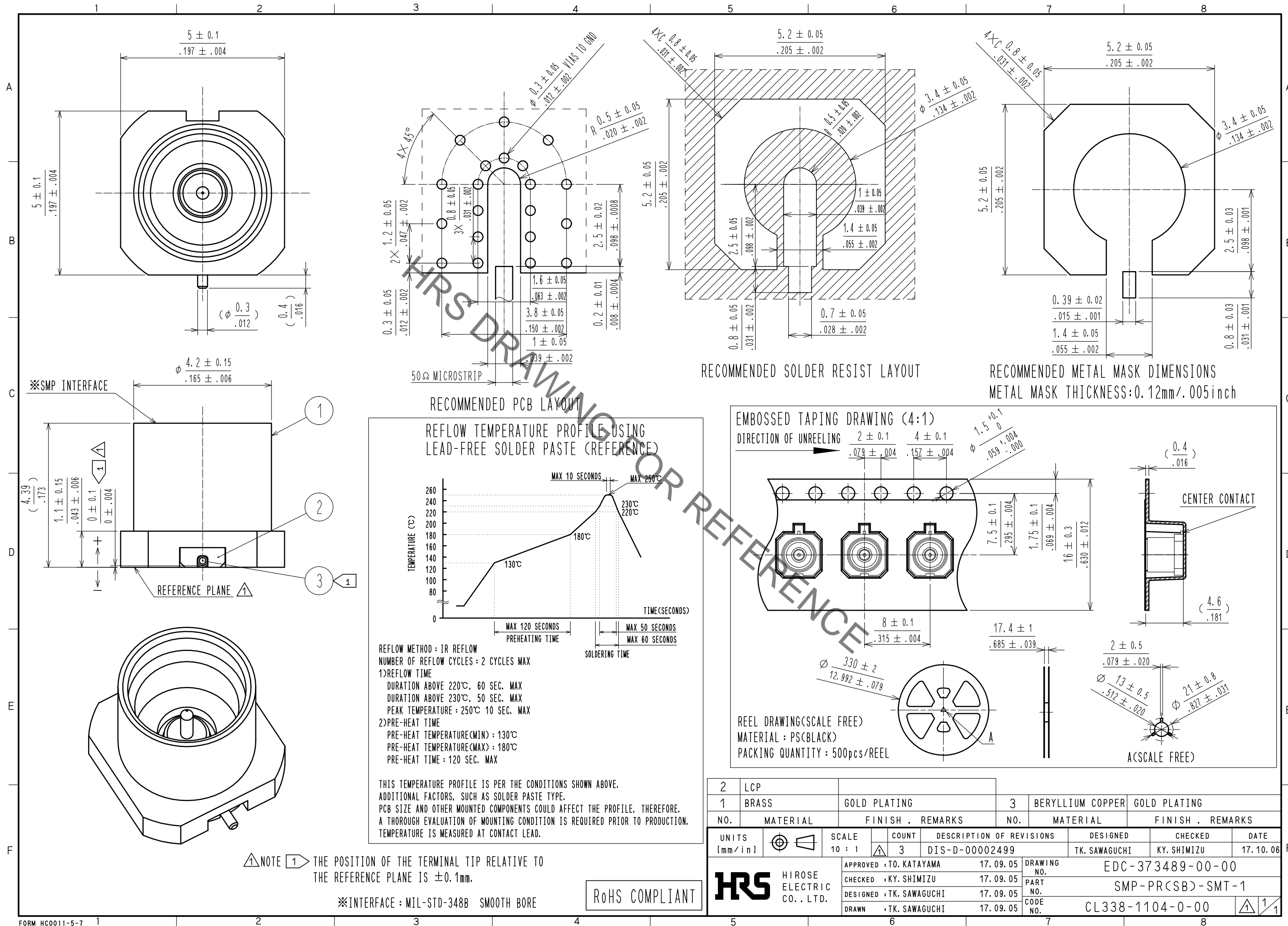

2	LCP		3	BERYLLIUM COPPER	GOLD PLATING		
1	BRASS	GOLD PLATING					
NO.	MATERIAL	FINISH	REMARKS	NO.	MATERIAL	FINISH	REMARKS
UNITS	[mm/in]	SCALE	10 : 1	COUNT	3	DESCRIPTION OF REVISIONS	DIS-D-00002499
APPROVED : TO. KATAYAMA 17.09.05				DESIGNED : TK. SAWAGUCHI			
CHECKED : KY. SHIMIZU 17.09.05				CHECKED : KY. SHIMIZU 17.09.05			
DESIGNED : TK. SAWAGUCHI 17.09.05				DRAWING NO. EDC-373489-00-00			
DRAWN : TK. SAWAGUCHI 17.09.05				PART NO. SMP-PR(SB)-SMT-1			
				CODE NO. CL338-1104-0-00			

NOTE 1 THE POSITION OF THE TERMINAL TIP RELATIVE TO THE REFERENCE PLANE IS ±0.1mm.

※INTERFACE : MIL-STD-348B SMOOTH BORE

ROHS COMPLIANT