

THIS COPY IS PROVIDED ON A RESTRICTED BASIS AND IS NOT TO BE USED IN ANY WAY DETRIMENTAL TO THE INTERESTS OF PANDUIT CORP.

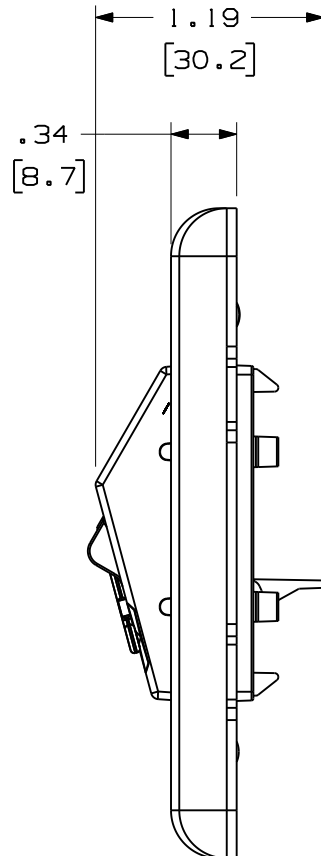
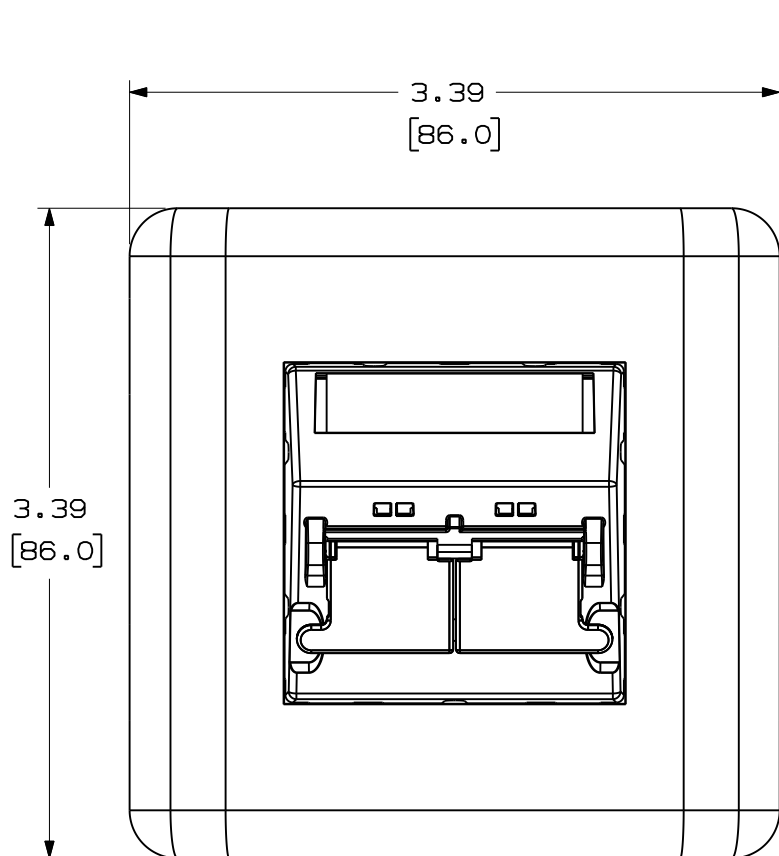

PANDUIT P/N	WEIGHT
CFPL86S2S**S	.090 LB/EACH 41.0 g/EACH

NOTES:

- SEE CURRENT CATALOG FOR ADDITIONAL PART NUMBER SUFFIXES TO INDICATE COLOR AND/OR PACKAGE QUANTITY.
- SEE CATALOG FOR COMPLETE LIST OF PARTS APPLICABLE FOR USE WITH THIS PART.
- DIMENSIONS IN [ ] ARE IN METRIC.
- PART INCLUDES:
  - 1- MOUNTING FRAME
  - 1- FACEPLATE COVER
  - 1- 2 POSITION 45mmX45mm SHUTTERED MODULE
  - 2- M3.5x0.5x30mm RSD COUNTERSINK SLOTTED MACHINE SCREWS

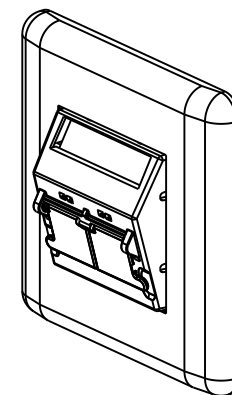

MODEL FILENAME	12M320AA/01	SIZE	A
DRAWING FILENAME	12M320AA_DC02/00A		
MINI-COM 2 POSITION SLOPED SHUTTERED 86X86 STAINLESS STEEL FACEPLATE CUSTOMER DRAWING			
 TINLEY PARK, IL 60487		I.I. NUMBER	
		PRODUCT SPEC/ PKG SPEC	
 THIRD ANGLE PROJECTION		ASSY METHOD/ TEST METHOD	
		SCALE NONE	
DRAWN BY BJJ		PART NO.	
DATE 3-12-12		CFPL86S2S**S	
CHK'D RJDU		DRAWING NO.	
REVIEW DRAWING NUMBERS		12M320AA-02	
MATERIAL STAINLESS STEEL & ABS			

REV	DATE	BY	CHK	DESCRIPTION	ECN	R	CUST	SUP	OTH
R	3-12-12	BJJ	RJDU	RELEASED TO PRODUCTION	12M320AA-02	RJDU	RJDU		