

May.1.2023 Copyright 2023 HIROSE ELECTRIC CO., LTD. All Rights Reserved.  
In case of consideration for using Automotive equipment / device which demand high reliability, kindly contact our sales window correspondents.

COUNT	DESCRIPTION OF REVISIONS	B	Y	CHKD	DATE	COUNT	DESCRIPTION OF REVISIONS	B	Y	CHKD	DATE
△ 1	RE-6-0599	J.S.H	J.H.W		16. 01. 12	△					
△						△					
△						△					

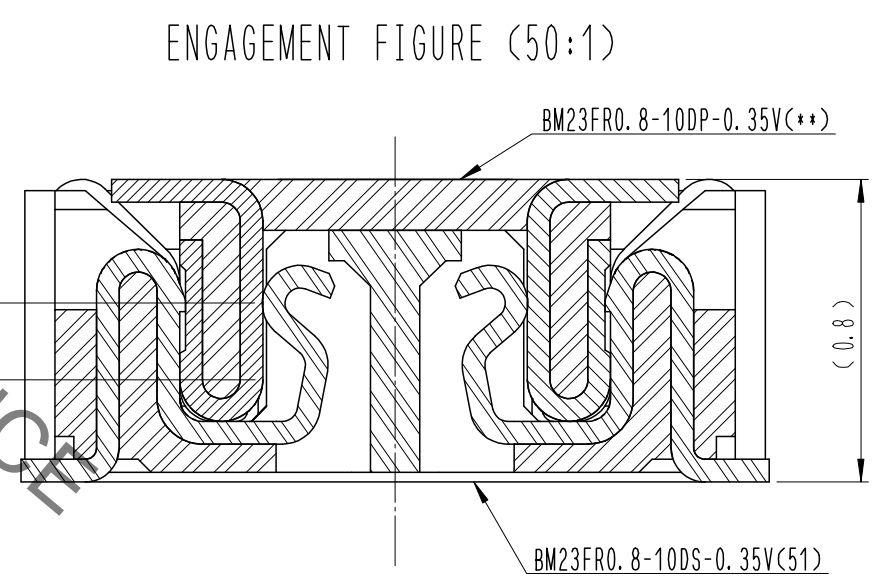
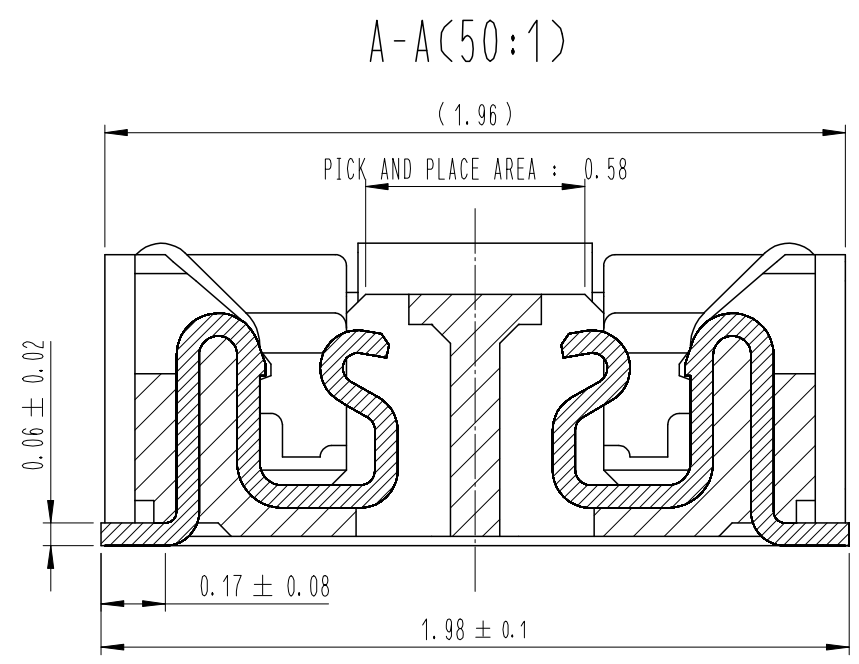
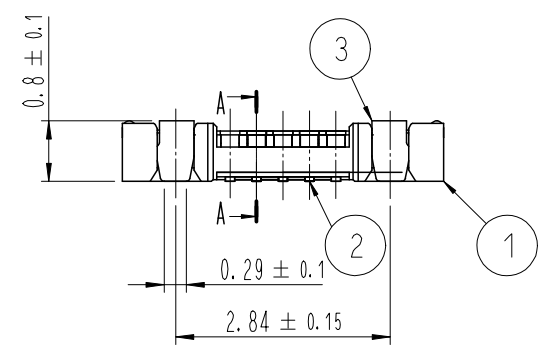
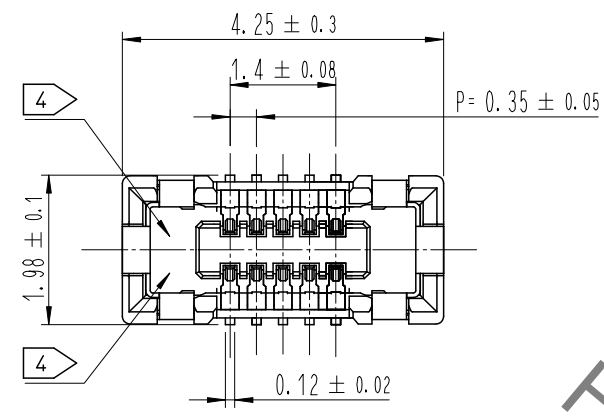

DRAWING FOR REFERENCE  
This is subject to change without notice

- NOTE
- 1 . ALL LEAD CO-PLANARITY SHALL BE 0.08mm MAX.
  - 2 . CONTACT PLATING SPECIFICATIONS.  
CONTACT AREA : GOLD 0.05 μm MIN.  
SMT LEAD : GOLD 0.05 μm MIN.  
UNDERPLATING : NICKEL 1 μm MIN.  
( SURFACE : SEALING )
  - 3 . MATAL FITTING PLATING SPECIFICATIONS.  
SMT LEAD : GOLD 0.05 μm MIN.  
UNDERPLATING : NICKEL 1 μm MIN.  
( SURFACE : SEALING )
  - 4 . HRS MARK AND CAV NO. IS INDICATED IN APPROX POSITION SHOWN.

4	PS	CLEAR (EMBOSSED CARRIER TAPE)			
3	PHOSPHOR BRONZE	3			
2	PHOSPHOR BRONZE	2	6	PS	BLACK (PLASTIC REEL)
1	LCP	UL94 V-0, BLACK	5	POLYESTER	CLEAR (COVER TAPE)
NO.	MATERIAL	FINISH, REMARKS	NO.	MATERIAL	FINISH, REMARKS
REMARKS			DRAWN	DESIGNED	CHECKED
			Y. J. LEE	Y. J. LEE	H. W. JO
			15. 06. 16	15. 06. 16	15. 06. 16
			APPROVED	RELEASED	
			T. S. KANG		16. 01. 12
			15. 06. 16		
CODE NO. (OLD)	DRAWING NO. EDC3-631868		PART NO. BM23FR0. 8-10DS-0.35V(51)		
SCALE 10:1	HRS HIROSE KOREA CO., LTD.		CODE NO. CL 6644-0020-1-051		1/3
UNITS mm					

May.1.2023 Copyright 2023 HIROSE ELECTRIC CO., LTD. All Rights Reserved.  
In case of consideration for using Automotive equipment / device which demand high reliability, kindly contact our sales window correspondents.

6 RECOMMENDED PCB LAYOUT

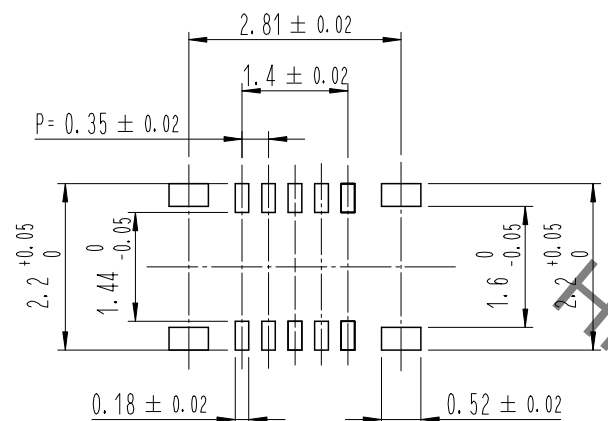

RECOMMENDED METAL MASK DIMENSIONS  
METAL MASK THICKNESS : 100 μm

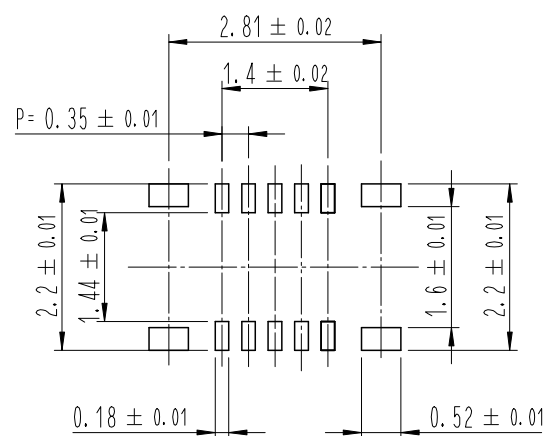

5 RECOMMENDED REFLOW TEMPERATURE PROFILE USING LEAD-FREE SOLDER PASTE.

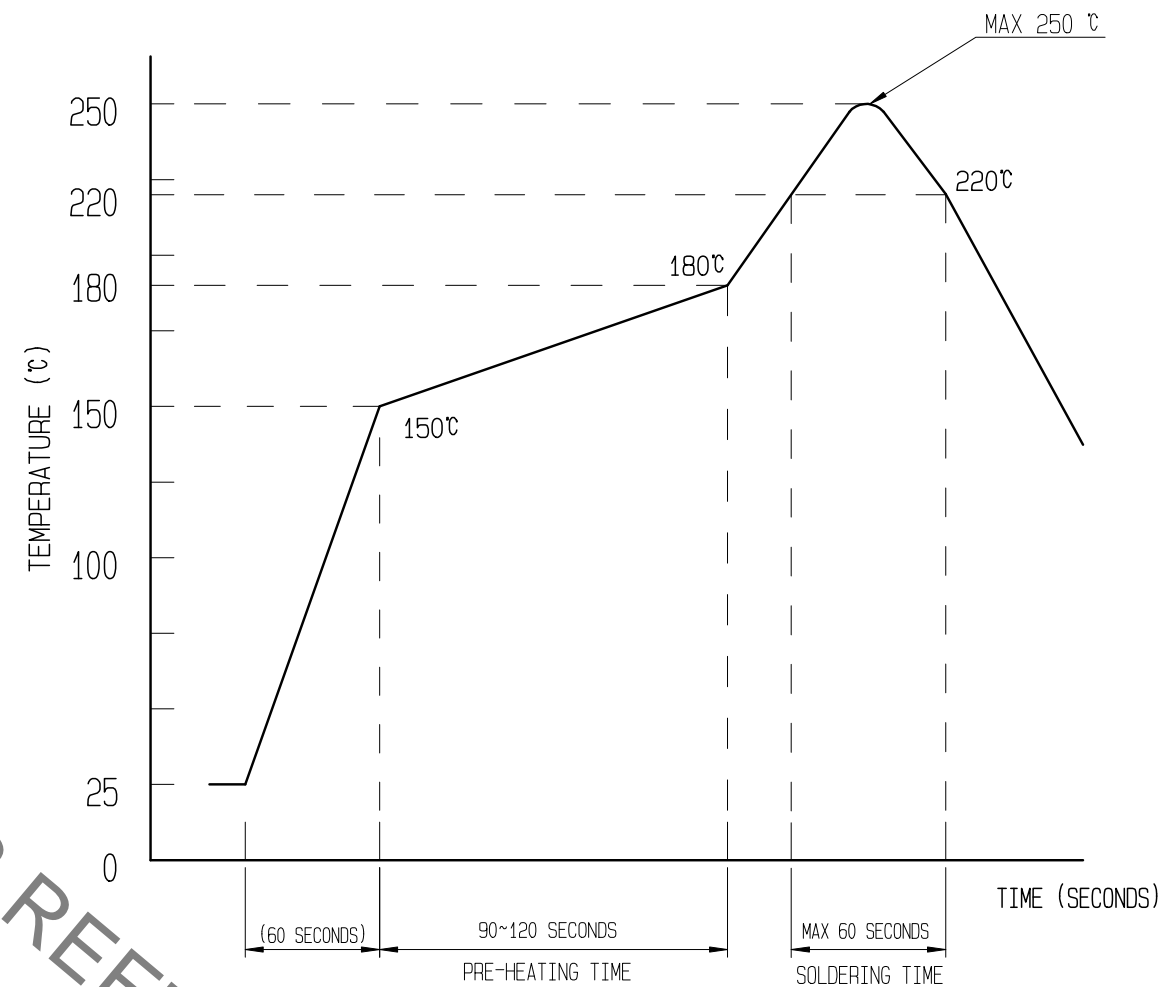

REFLOW METHOD: IR REFLOW  
 NUMBER OF REFLOW CYCLES: 2 CYCLES MAX.  
 1) REFLOW TIME  
 DURATION ABOVE 220°C: 60 SEC MAX.  
 (PEAK TEMPERATURE: 250°C MAX)  
 2) PRE-HEAT TIME  
 PRE-HEAT TEMPERATURE(MIN): 150°C  
 PRE-HEAT TEMPERATURE(MAX): 180°C  
 PRE-HEAT TIME: 90-120 SEC.

5. THIS TEMPERATURE PROFILE IS PER THE CONDITIONS SHOWN ABOVE. ADDITIONAL FACTORS, SUCH AS SOLDER PASTE TYPE, PCB SIZE AND OTHER MOUNTED COMPONENTS COULD AFFECT THE PROFILE, THEREFORE, A THOROUGH EVALUATION OF MOUNTING CONDITION IS REQUIRED PRIOR TO PRODUCTION. TEMPERATURE IS MEASURED AT CONTACT LEAD.
6. PLEASE CONTACT US IN CASE YOU WILL MAKE DIFFERENT SETTINGS FROM OUR RECOMMENDATION.

	DRAWING NO.	EDC3-631868	PART NO.	BM23FR0.8-10DS-0.35V(51)
	SCALE	10:1	CODE NO	CL 6644-0020-1-051
UNITS	HRS HIROSE KOREA CO., LTD.			2/3

In case of consideration for using Automotive equipment / device which demand high reliability, kindly contact our sales window correspondents.

# EMBOSED CARRIER TAPE PACKAGING (5:1)

# STYLE AND DIMENTION OF REEL (FREE)

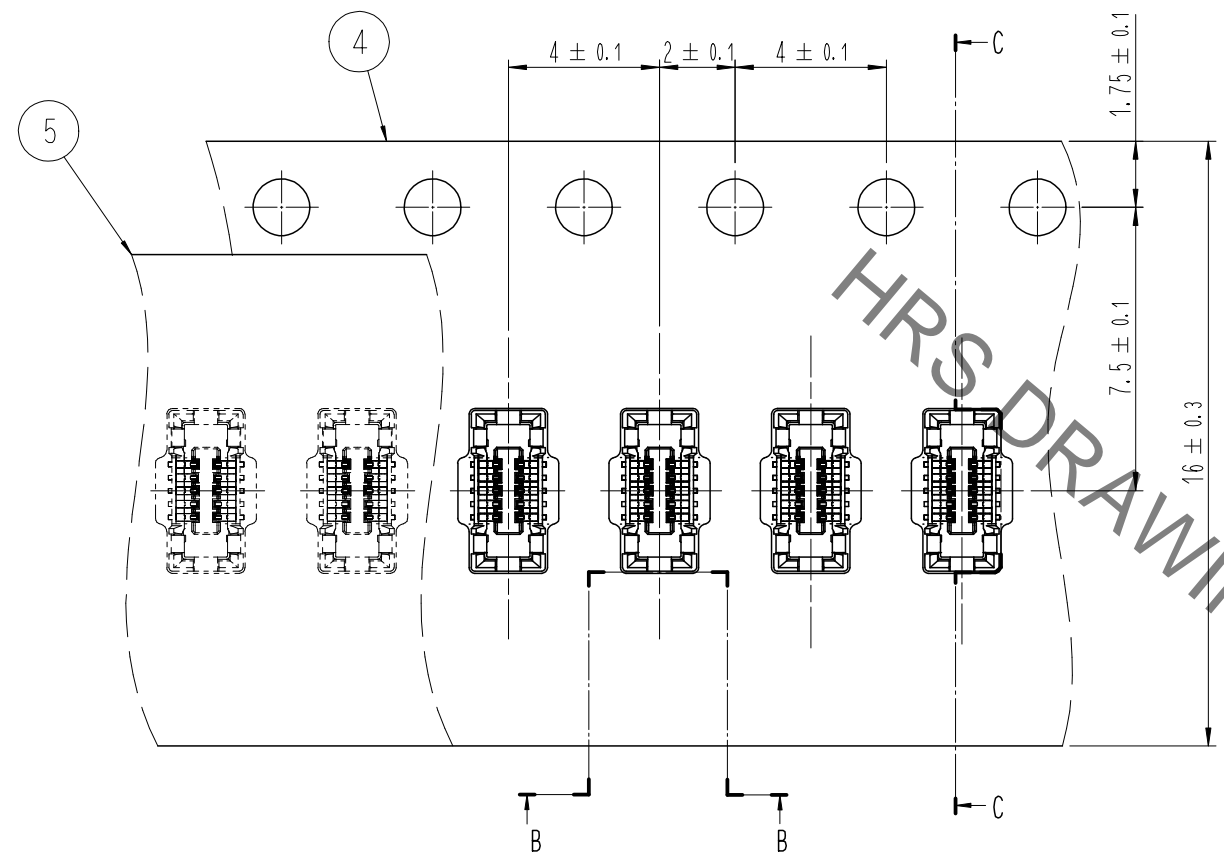

C-C (5:1)

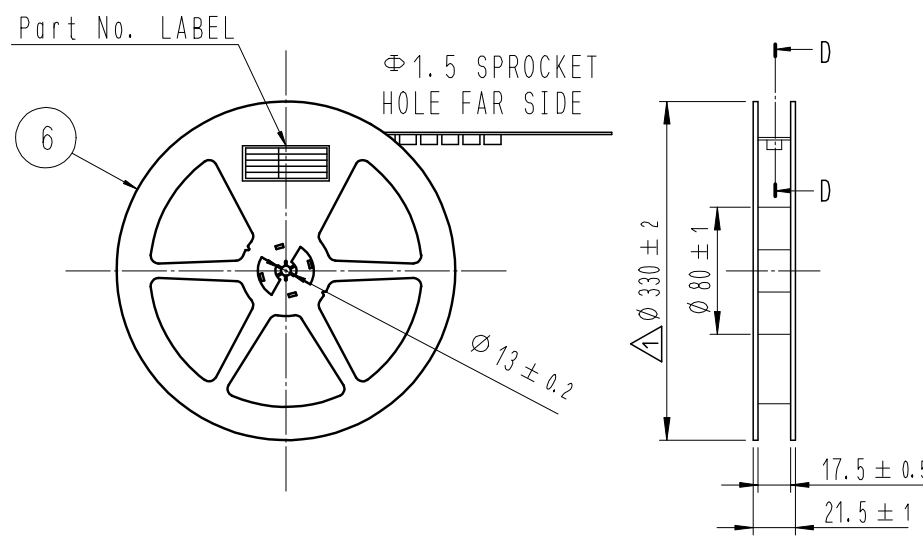
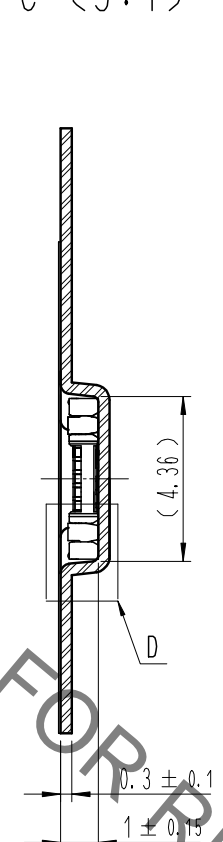

E-E (FREE)

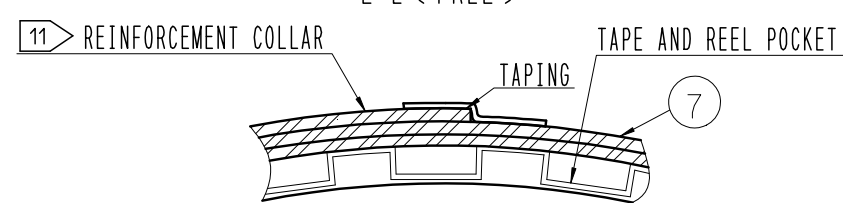

## DETAIL OF PART No. LABEL

SUPPLIER	HIROSE
QUANTITY	10,000
PART NO.	BM23FR0.8-10DS-0.35V(51)
CODE NO.	CL 6644-0020-1-051
DATE OF MANUFACTURED	年 月 日
生産月日	年 月 日
図番	** ** *
品名	BM23FR0.8-10DS-0.35V(51)
納入数量	10,000個
納入者	HIROSE KOREA

B-B (5:1)

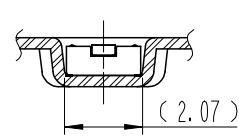

DIRECTION OF UNREELING

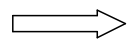

D (10:1)

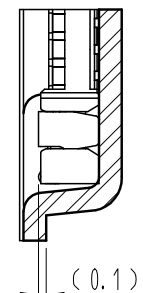

9 TAPING(FREE)

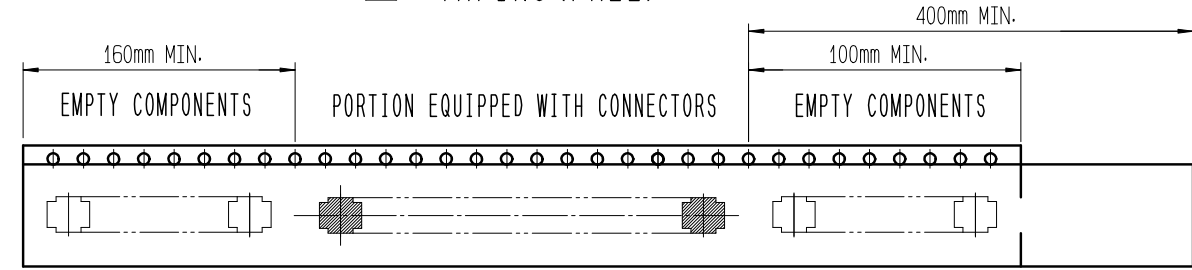

- 8 . PER REEL 10,000 CONNECTORS.
- 9 . THE DIMENSIONS IN PARENTHESES ARE FOR REFERENCE.
- 10 REFER TO JIS C 0806, IEC-60286-3 (PACKAGING OF COMPONENTS FOR AUTOMATIC HANDLING)
- 11 AFTER PACKAGING, ROLL 2 METERS OF THE REINFORCEMENT COLLAR TO OUTER CIRCUMFERENCE OF TAPE AND REEL POCKET. AND TAPE DOWN AT THE END THE COLLAR.

SCALE 10:1 UNITS mm	DRAWING NO. EDC3-631868	PART NO. BM23FR0.8-10DS-0.35V(51)
	HIROSE KOREA CO., LTD.	CODE NO. CL 6644-0020-1-051