

May.1.2023 Copyright 2023 HIROSE ELECTRIC CO., LTD. All Rights Reserved.  
In case of consideration for using Automotive equipment / device which demand high reliability, kindly contact our sales window correspondents.

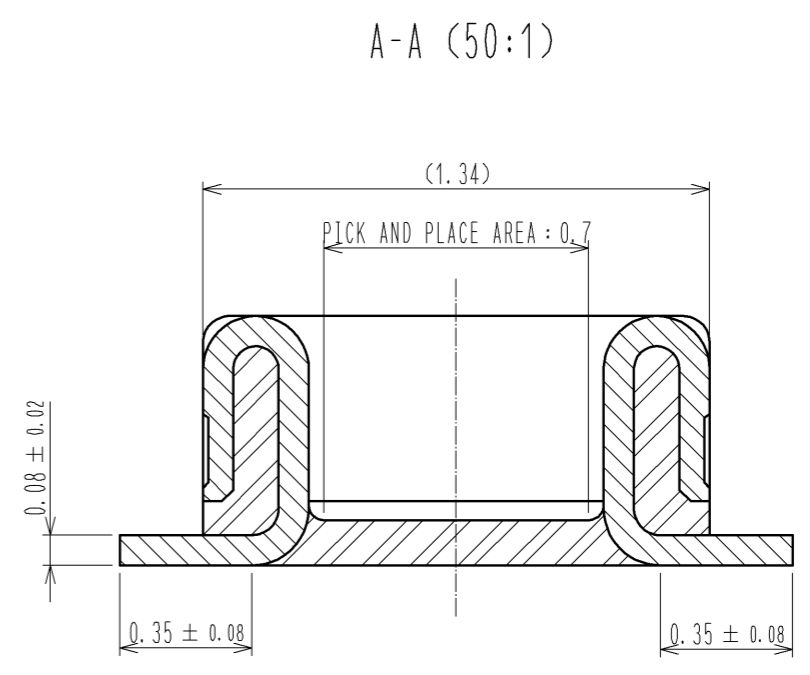

ENGAGEMENT FIGURE (50:1)

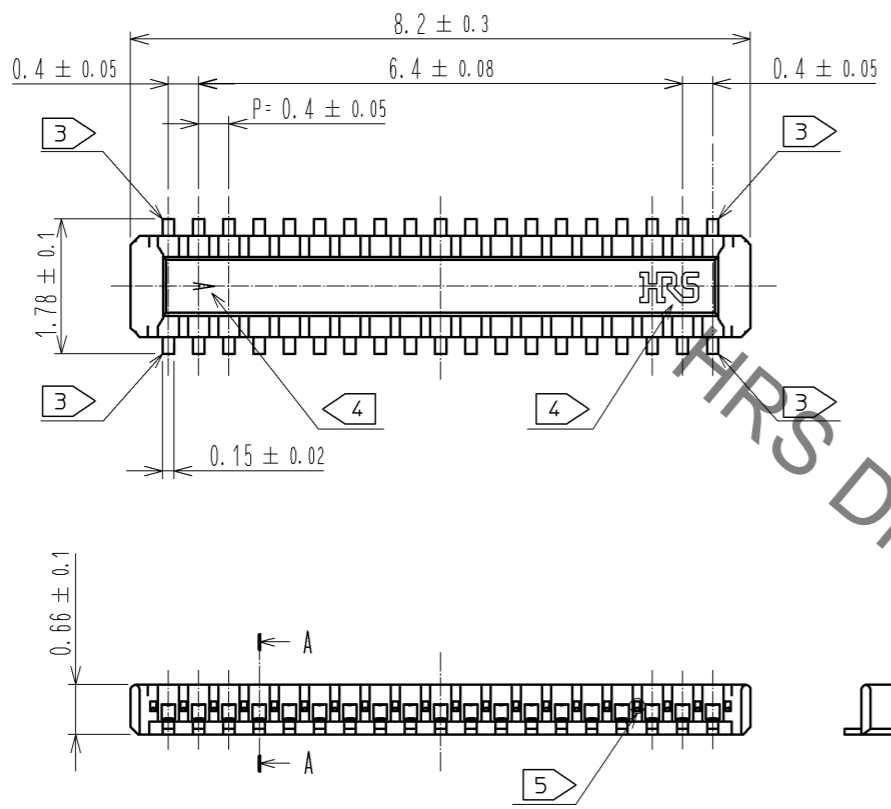
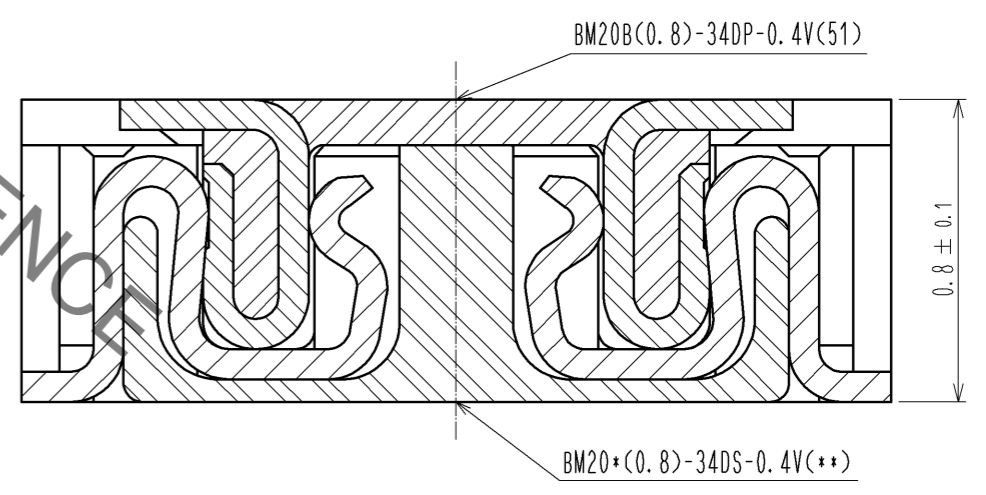

- NOTE 1 . ALL LEAD CO-PLANARITY SHALL BE 0.08mm MAX
- 2 CONTACT PLATING SPECIFICATIONS  
CONTACT AREA : GOLD 0.05 μm MIN  
SMT LEAD : GOLD 0.05 μm MIN  
UNDER PLATING : NICKEL 1 μm MIN  
( SURFACE : SEALING )
  - 3 EACH CONTACTS AT 4 CORNERS ARE PROVIDED FOR METAL FITTINGS.
  - 4 HRS MARK AND CAV No. ARE INDICATED IN APPROX POSITION SHOWN.
  - 5 A PART OF THE WALL COULD BE NOTCHED.

NO.	MATERIAL	FINISH . REMARKS	NO.	MATERIAL	FINISH . REMARKS
3	PS	CLEAR (EMBOSSED CARRIER TAPE)	6	PS	CLEAR (REINFORCEMENT COLLAR)
2	PHOSPHOR BRONZE	2	5	PS	BLACK (PLASTIC REEL)
1	LCP	UL94 V-0, BLACK	4	POLYESTER	CLEAR (COVER TAPE)

UNITS	SCALE	COUNT	DESCRIPTION OF REVISIONS	DESIGNED	CHECKED	DATE
mm	10:1	△				
HIROSE ELECTRIC CO., LTD.			APPROVED : KH. IKEDA 12.03.13 CHECKED : TS. MIYAZAKI 12.03.13 DESIGNED : YK. SATAKE 12.03.12 DRAWN : KR. AJITO 12.03.09	DRAWING NO. EDC3-343535-01 PART NO. BM20B(0.8)-34DP-0.4V(51) CODE NO. CL684-9019-0-51		

May.1.2023 Copyright 2023 HIROSE ELECTRIC CO., LTD. All Rights Reserved.  
 In case of consideration for using Automotive equipment / device which demand high reliability, kindly contact our sales window correspondents.

◆ RECOMMENDED PCB LAYOUT

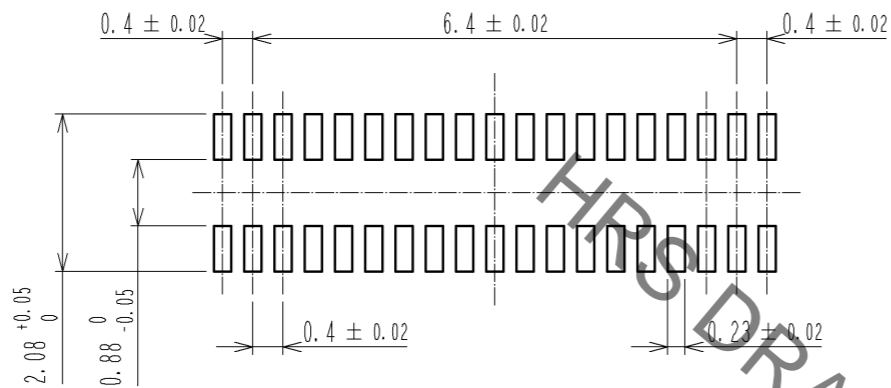

◆ RECOMMENDED METAL MASK DIMENSIONS

METAL MASK THICKNESS :  $100 \mu\text{m}$

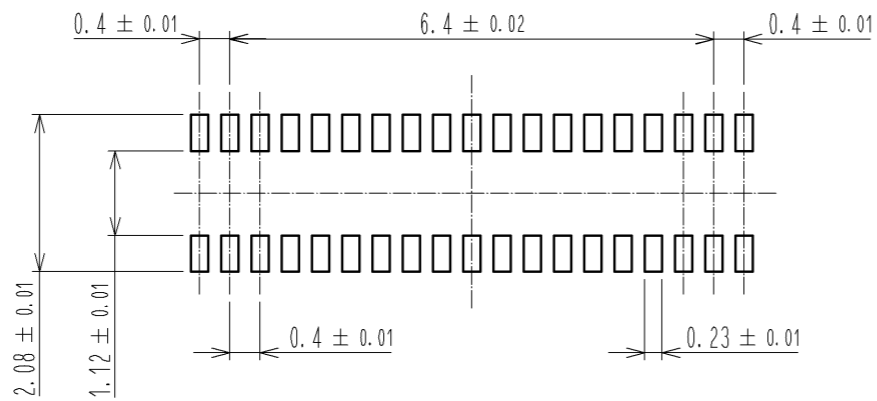

6 RECOMMENDED REFLOW TEMPERATURE PROFILE USING LEAD-FREE SOLDER PASTE.

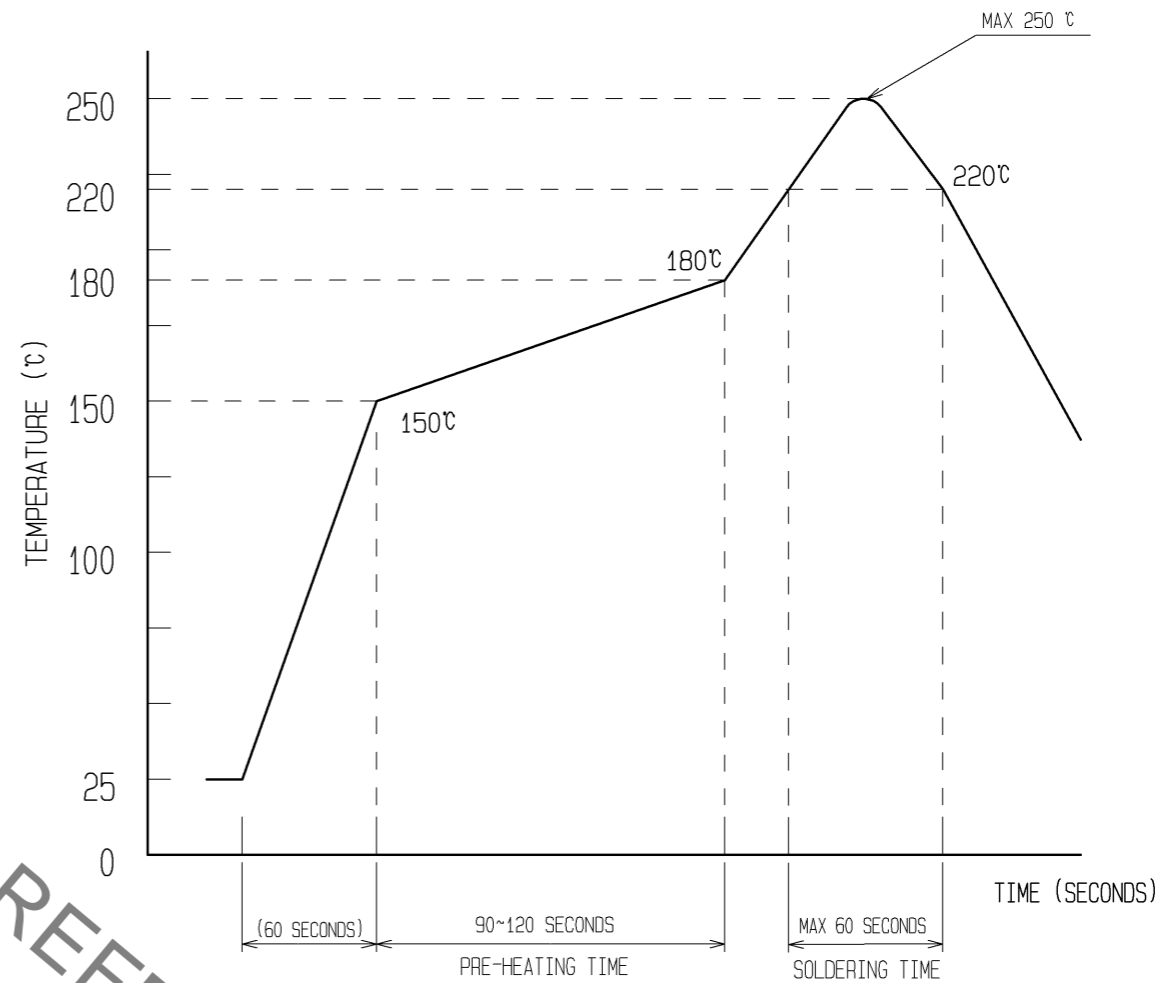

REFLOW METHOD: IR REFLOW  
 NUMBER OF REFLOW CYCLES: 2 CYCLES MAX.  
 1) REFLOW TIME  
 DURATION ABOVE 220°C: 60 SEC MAX.  
 (PEAK TEMPERATURE: 250°C MAX)  
 2) PRE-HEAT TIME  
 PRE-HEAT TEMPERATURE(MIN): 150°C  
 PRE-HEAT TEMPERATURE(MAX): 180°C  
 PRE-HEAT TIME: 90-120 SEC.

6 THIS TEMPERATURE PROFILE IS PER THE CONDITIONS SHOWN ABOVE. ADDITIONAL FACTORS, SUCH AS SOLDER PASTE TYPE, PCB SIZE AND OTHER MOUNTED COMPONENTS COULD AFFECT THE PROFILE. THEREFORE, A THOROUGH EVALUATION OF MOUNTING COONDITION IS REQUIRED PRIOR TO PRODUCTION. TEPERATURE IS MEASURED AT CONTACT LEAD.

<b>HRS</b>	DRAWING NO.	EDC3-343535-01
	PART NO.	BM20B(0.8)-34DP-0.4V(51)
	CODE NO.	CL684-9019-0-51

2/3

May.1.2023 Copyright 2023 HIROSE ELECTRIC CO., LTD. All Rights Reserved.  
 In case of consideration for using Automotive equipment / device which demand high reliability, kindly contact our sales window correspondents.

### EMBOSED CARRIER TAPE PACKAGING (5:1)

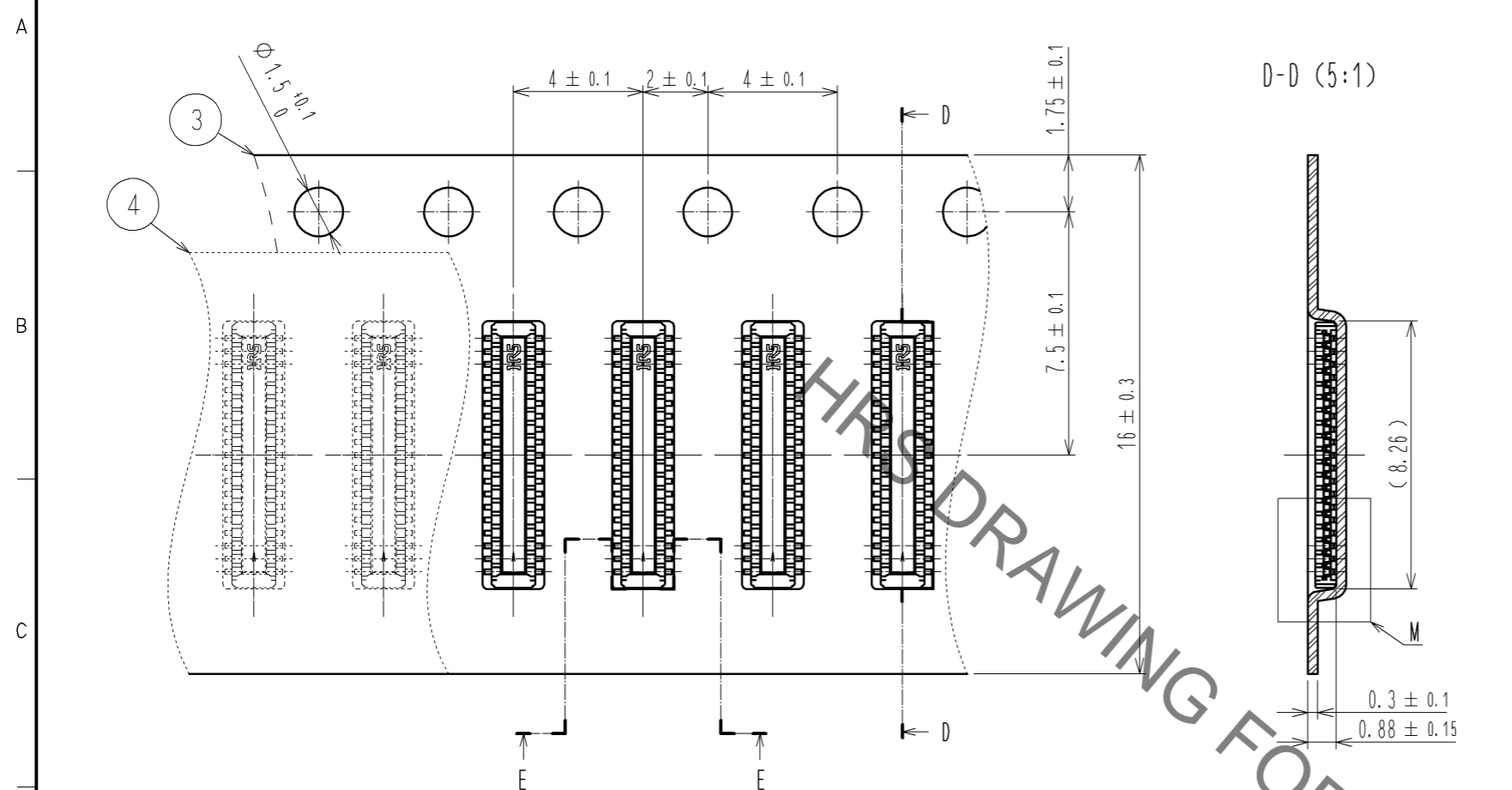

DIRECTION OF UNREELING

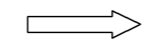

#### E-E (5:1)

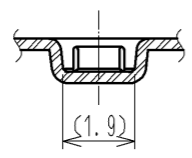

#### D-D (5:1)

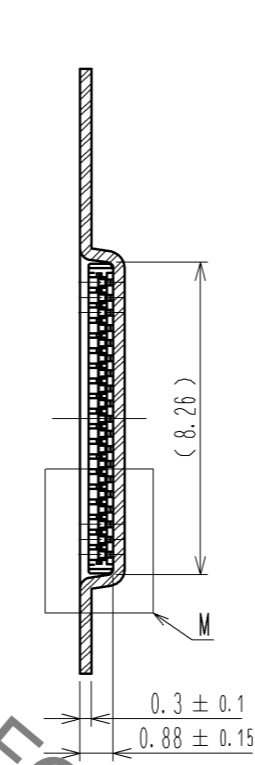

### STYLE AND DIMENTION OF REEL (FREE)

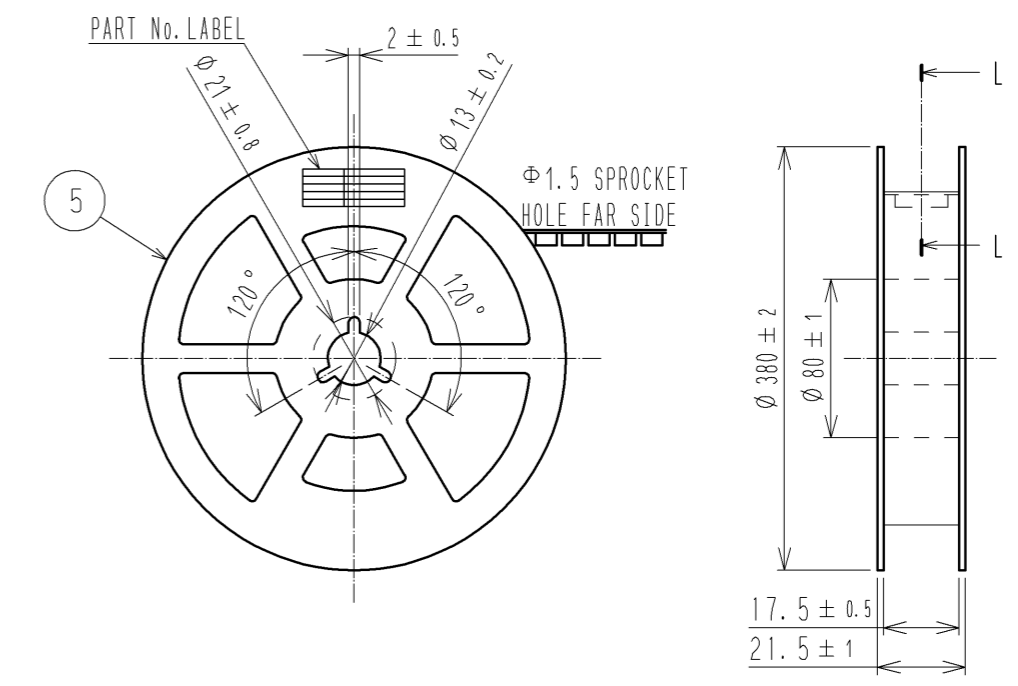

#### L-L (FREE)

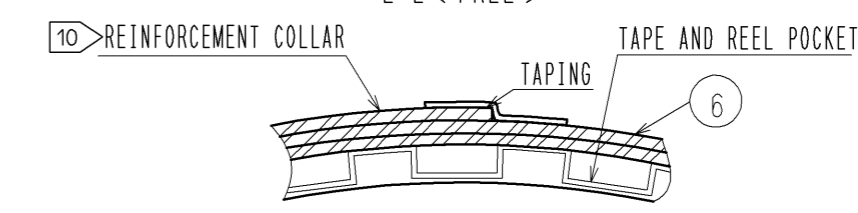

#### DETAIL OF PART No. LABEL

製造年月日	** ** *	DATE OF MANUFACTURED
製品コード	CL684-9019-0-51	CODE No.
製品名	BM20B(0.8)-34DP-0.4V(51)	PART No.
数量	8,000	QUANTITY
納入者	ヒロセ電機(株)	SUPPLIER

- 7. PER REEL 8000 CONNECTORS.
- 8. THE DIMENTION IN PARENTHESSES ARE FOR REFERENCE.
- 9 REFER TO JIS C 0806(PACKAGING OF COMPONENTS FOR AUTOMATIC HANDLING)
- 10 AFTER PACKAGING, ROLL 2 METERS OF THE REINFORCEMENT COLLAR TO OUTER CIRCUMFERENCE OF TAPE AND REEL POCKET. AND TAPE DOWN AT THE END THE COLLAR.

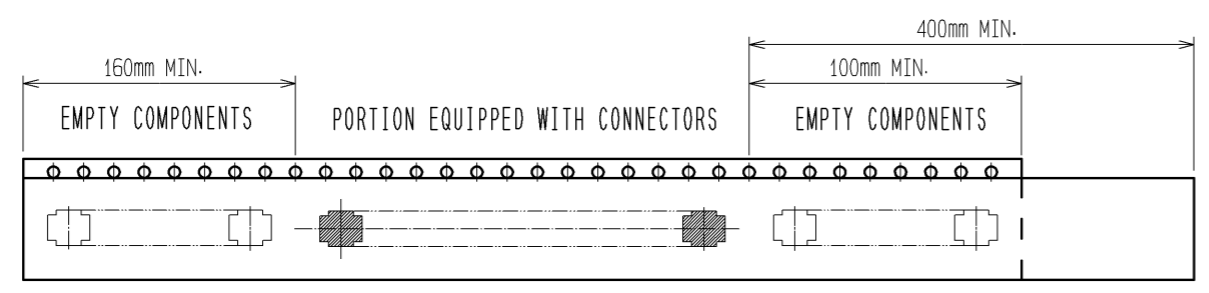

#### M (10:1)

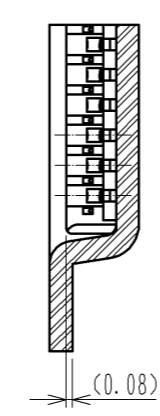

<b>HRS</b>	DRAWING NO.	EDC3-343535-01
	PART NO.	BM20B(0.8)-34DP-0.4V(51)
	CODE NO.	CL684-9019-0-51
		△ 3/3