

Apr.1.2023 Copyright 2023 HIROSE ELECTRIC CO., LTD. All Rights Reserved.
In case of consideration for using Automotive equipment / device which demand high reliability, kindly contact our sales window correspondents.

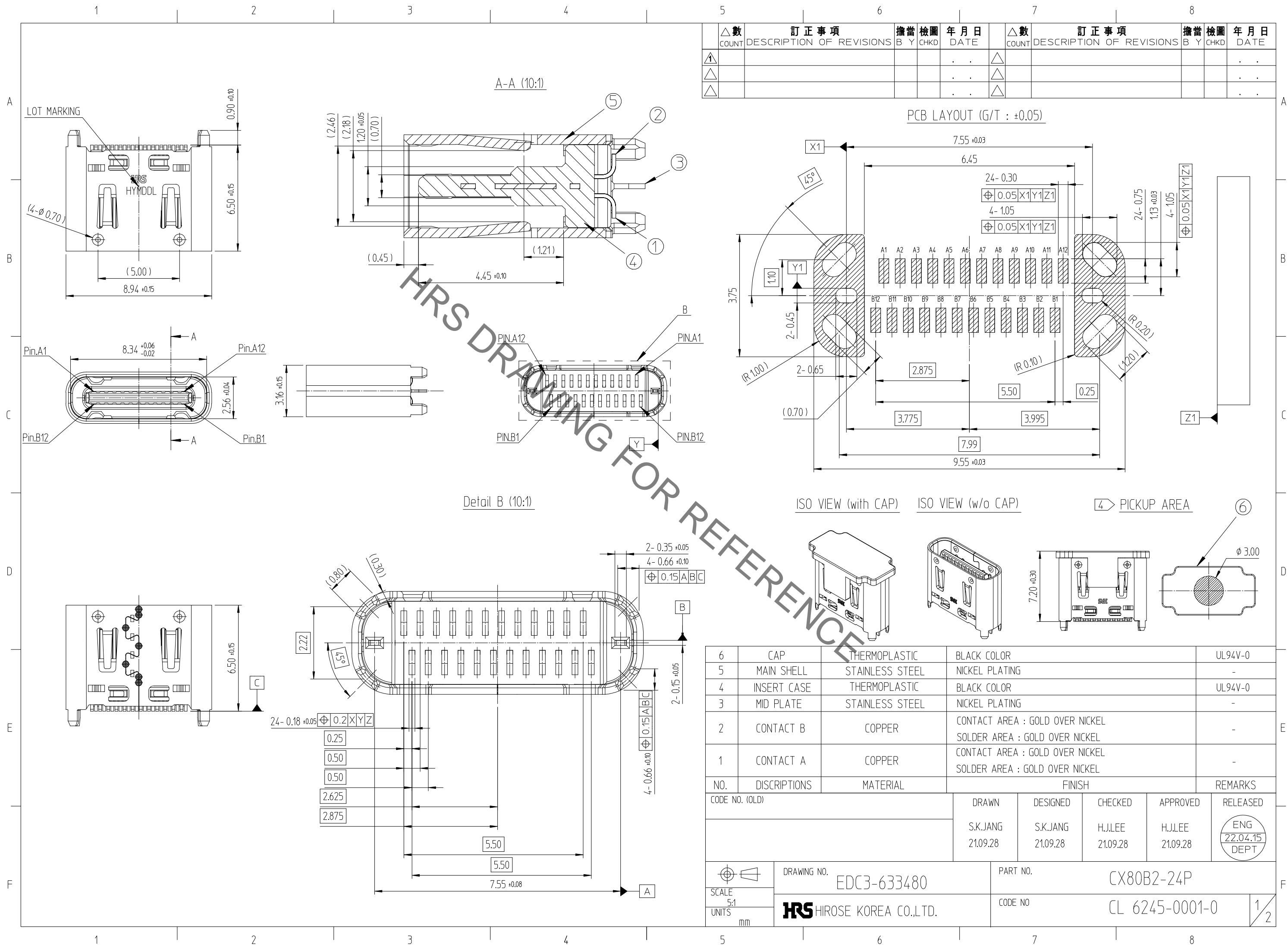

△數 COUNT	訂正事項 DESCRIPTION OF REVISIONS	擔當 B	檢圖 CHKD	年月日 DATE	△數 COUNT	訂正事項 DESCRIPTION OF REVISIONS	擔當 B	檢圖 CHKD	年月日 DATE
△1					△				
△					△				
△					△				

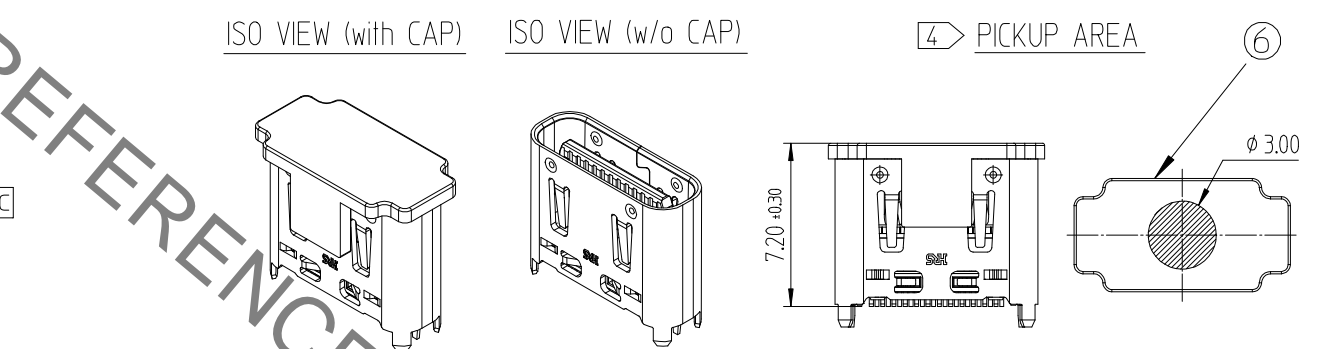
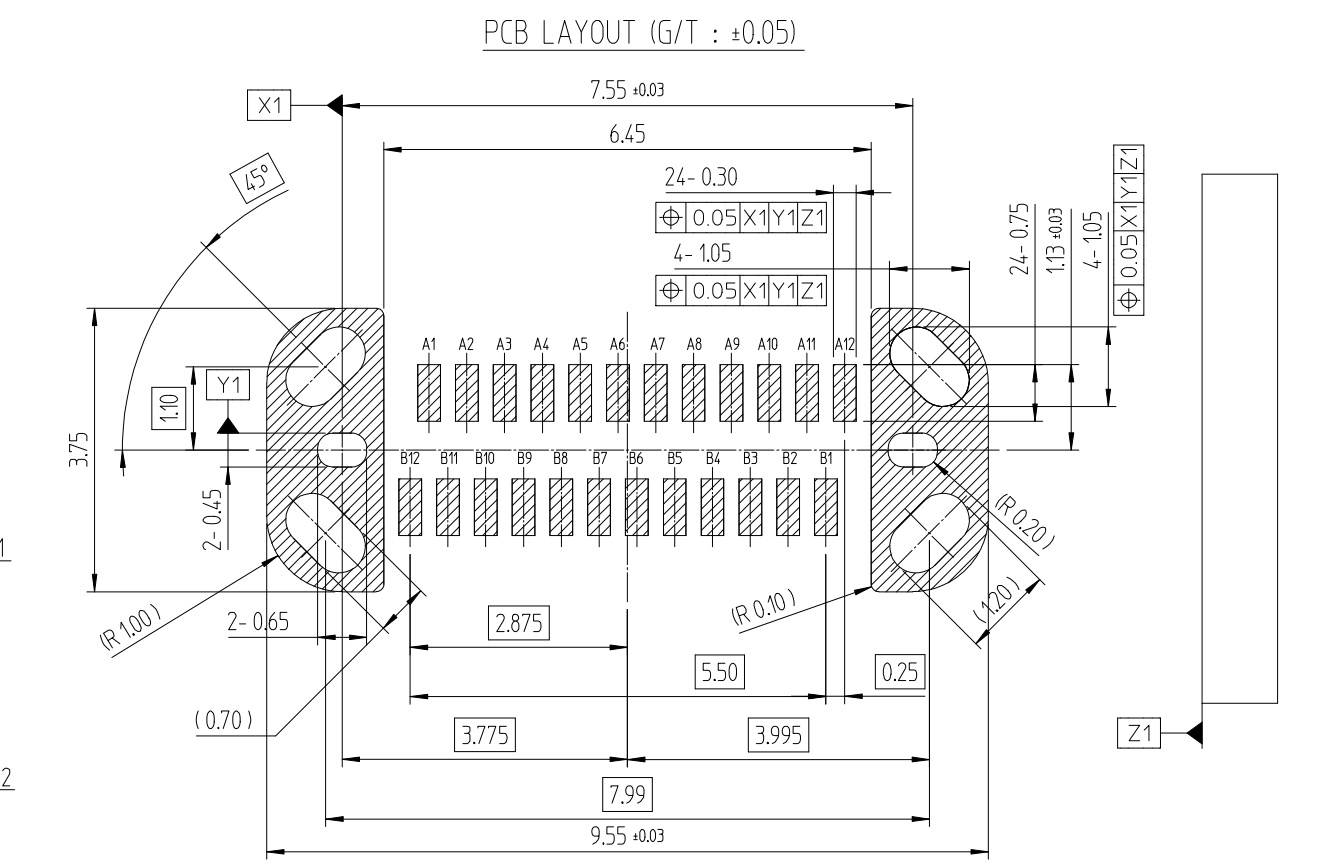

NO.	DISCRIPTIONS	MATERIAL	FINISH	REMARKS
6	CAP	THERMOPLASTIC	BLACK COLOR	UL94V-0
5	MAIN SHELL	STAINLESS STEEL	NICKEL PLATING	-
4	INSERT CASE	THERMOPLASTIC	BLACK COLOR	UL94V-0
3	MID PLATE	STAINLESS STEEL	NICKEL PLATING	-
2	CONTACT B	COPPER	CONTACT AREA : GOLD OVER NICKEL SOLDER AREA : GOLD OVER NICKEL	-
1	CONTACT A	COPPER	CONTACT AREA : GOLD OVER NICKEL SOLDER AREA : GOLD OVER NICKEL	-

CODE NO. (OLD)	DRAWN	DESIGNED	CHECKED	APPROVED	RELEASED
	S.K.JANG 21.09.28	S.K.JANG 21.09.28	H.J.LEE 21.09.28	H.J.LEE 21.09.28	ENG 22.04.15 DEPT

SCALE 5:1 UNITS mm	DRAWING NO. EDC3-633480	PART NO. CX80B2-24P
	HRS HIROSE KOREA CO.,LTD.	CODE NO CL 6245-0001-0

Apr.1.2023 Copyright 2023 HIROSE ELECTRIC CO., LTD. All Rights Reserved.
In case of consideration for using Automotive equipment / device which demand high reliability, kindly contact our sales window correspondents.

DRAWING FOR PACKING

DIRECTION OF UNREELING

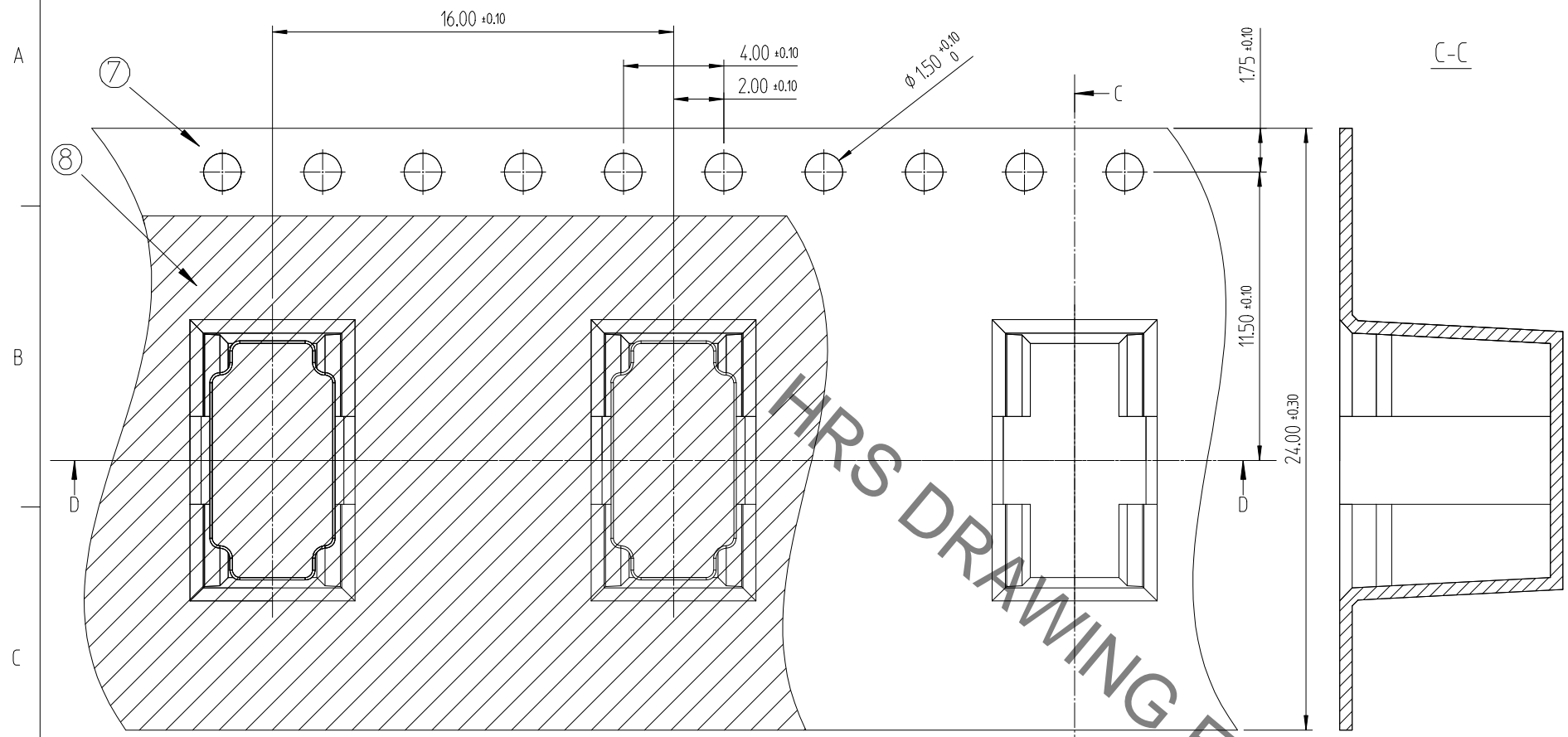

PIN ASSIGNMENT(FRONT-VIEW)

A1	A2	A3	A4	A5	A6	A7	A8	A9	A10	A11	A12
GND	TX1+	TX1-	Vbus	CC1	D+	D-	SBU1	Vbus	RX2-	RX2+	GND
B12	B11	B10	B9	B8	B7	B6	B5	B4	B3	B2	B1

PACKING CONDITION

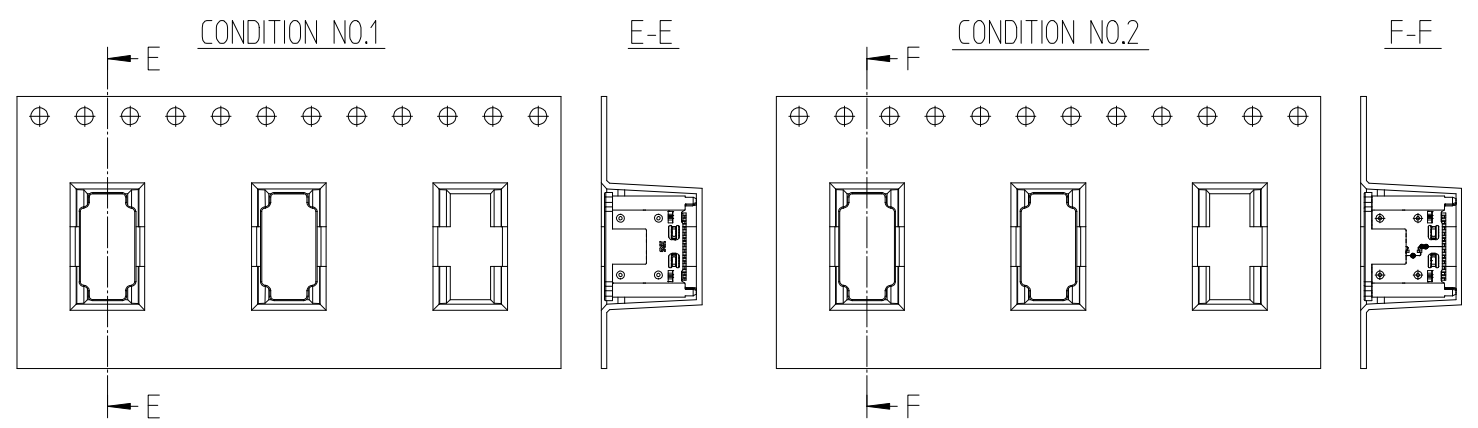

[NOTE]

1) Co-planarity of all contact tails
- 0.08MAX Before Reflow , 0.10MAX After Reflow 2times

2) Lot marking : 6 digits (HYMDDL)

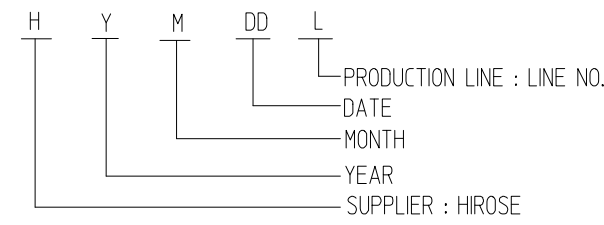

MARKER	YEAR	MONTH	DAY	LINE	MARK	
HIROSE	2017	7	JAN	1	1st 01	MANUAL M
	2018	8	FEB	2	2nd 02	AUTO 1 1
	2019	9	MAR	3	3th 03	AUTO 2 2
	2020	0	APR	4	4th 04	AUTO 3 3
	2021	1	MAY	5	5th 05	
	2022	2	JUN	6	6th 06	
	2023	3	JUL	7	7th 07	
	2024	4	AUG	8	8th 08	
	2025	5	SEP	9	9th 09	
	2026	6	OCT	A	10th 10	
			NOV	B	11th 11	
			DEC	C	...	

3. Carrier tape packing
Packing quantity : 600EA/REEL
Cover tape peeling force : 30~100gf(0.3~1.0N) @ 300mm/min

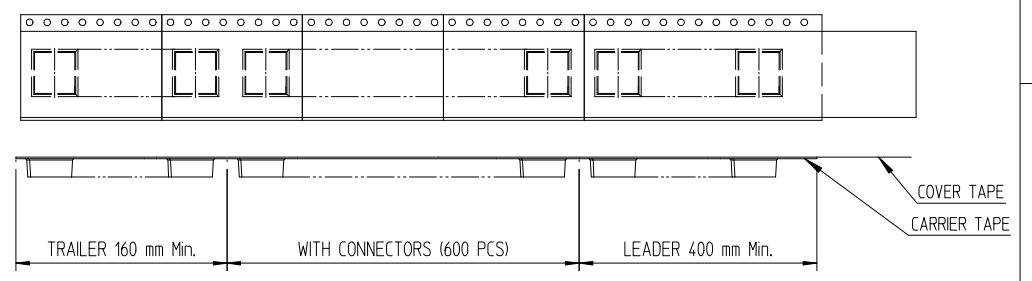

4) PICKUP AREA

5. APPLICABLE MASK
THICKNESS : 0.10mm
OPEN RATE : 120%

6) PACKING CONDITION

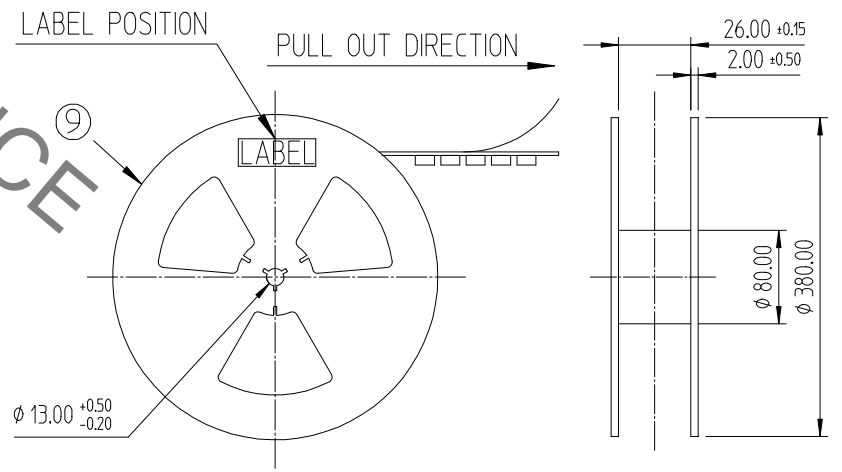

9	REEL BOBBIN	PS	-	-
8	COVER TAPE	PET	-	-
7	EMBOSS TAPE	PS	-	-
NO.	DISCRIPTIONS	MATERIAL	FINISH	REMARKS

SCALE 4:1 UNITS mm	DRAWING NO. EDC3-633480	PART NO. CX80B2-24P
	HRS HIROSE KOREA CO.,LTD.	CODE NO CL 6245-0001-0