

REVISONS		DATE	DMN	APVD
LOC	DIST	DESCRIPTION		
D	REV PER ECO	15-005906	5-19-15	CT DM

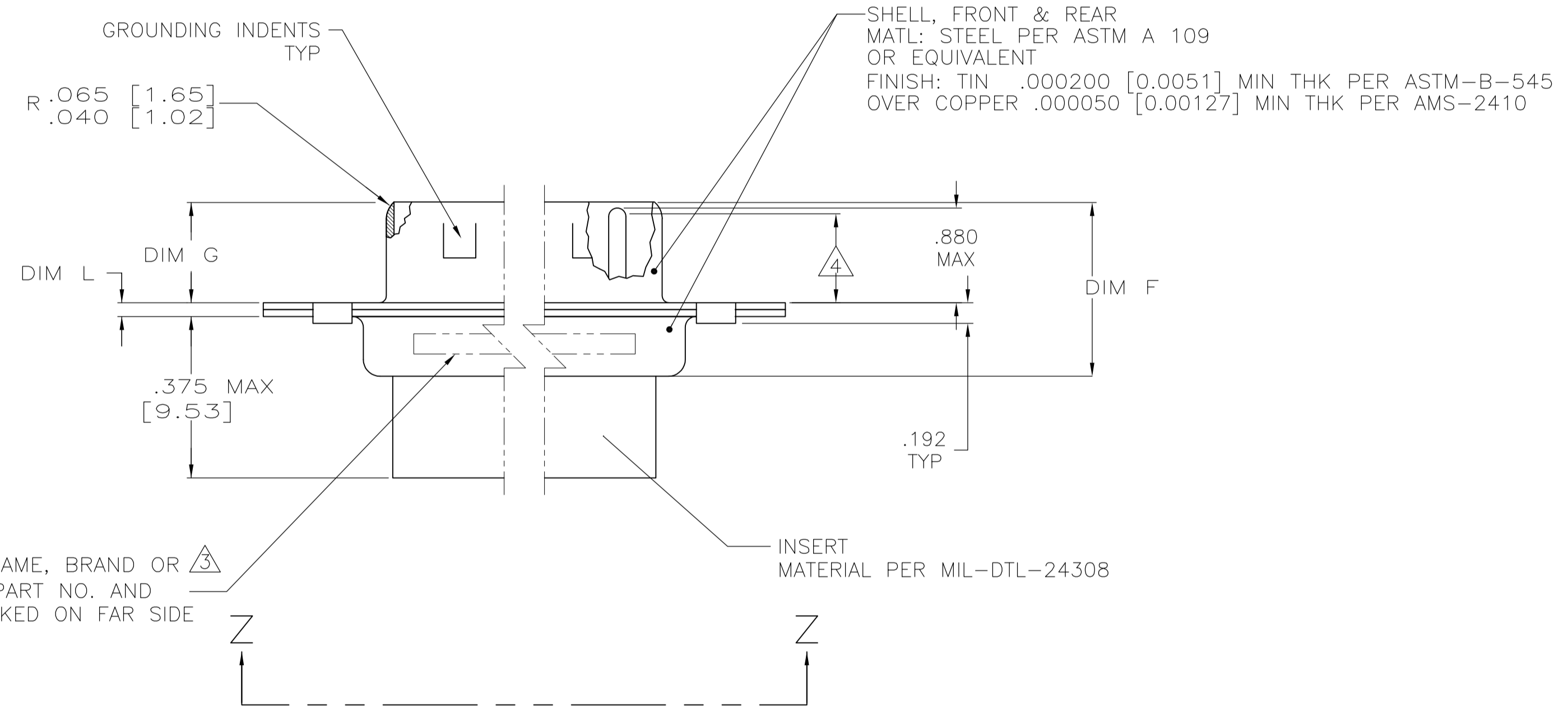
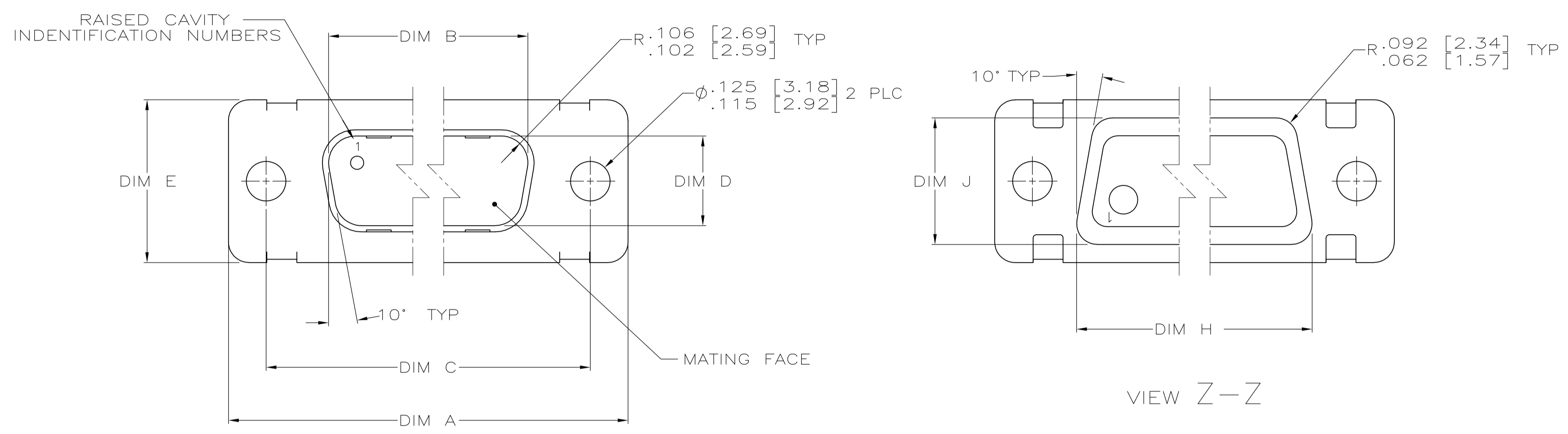

MARK MFG'S (NAME, BRAND OR LOGO), MFG'S PART NO. AND DATE CODE MARKED ON FAR SIDE

- THIS CONNECTOR ASSEMBLY IS SUPPLIED WITH METAL CONTACT RETENTION CLIPS INSTALLED IN THE INSERT ASSEMBLY.
- THIS CONNECTOR ASSEMBLY MEETS THE REQUIREMENTS OF MIL-C-24308 AND MATES WITH ANY RECEPTACLE CONNECTOR WITH THE SAME INSERT ARRANGEMENT.
- MARK WITH .047 [1.19]-.062 [1.57] HIGH CHARACTERS. FAR SIDE REFERS TO THE WIDE SIDE OF THE KEYSTONE. NEAR SIDE REFERS TO THE NARROW SIDE OF THE KEYSTONE. IF THE REAR SHELL IS TOO SMALL FOR THE ENTIRE MFG'S PART NUMBER, MARKING SHALL BE LOCATED AS FOLLOWS:
 A. MFG'S (NAME, BRAND OR LOGO) AND DATE CODE ON REAR SHELL, NEAR SIDE.
 B. MFG'S PART NUMBER ON REAR SHELL, FAR SIDE.
- REQUIREMENT FOR FULL PIN DIAMETER EXTENSION:
 .164 [4.17] MIN, SHELL SIZES 1 AND 2.
 .155 [3.94] MIN, SHELL SIZES 3, 4, AND 5.
 CONTACT SHOWN INSTALLED FOR DIMENSIONAL REFERENCE ONLY.
- MAXIMUM WIRE INSULATION TO BE USED WITH THIS CONNECTOR ASSEMBLY IS .072 [1.83] DIAMETER.
- FOR CONTACT CRIMPING INSTRUCTION SHEET REFER TO MFG'S IS 7516. FOR CONTACT INSTALLATION AND REMOVAL INSTRUCTION SHEET REFER TO TE I.S. 7508.
- THIS CONNECTOR ASSEMBLY IS DESIGNED TO ACCEPT SIZE 20 CRIMP TYPE PIN CONTACT MILITARY PART NO. M39029/64-369 (TE PART NO. 205089-1). FOR ALTERNATE CONTACT OPTIONS CONSULT THE TE CATALOG.
- THIS DRAWING SHALL BE INTERPRETED IN ACCORDANCE WITH APPLICABLE STANDARDS LISTED IN MIL-STD-100.

.049	1.24	.432	10.97	1.635	41.53	.238	6.04	.436	11.07	.509	12.93	.334	8.48	1.857	47.17	1.539	39.09	2.103	53.42	25	3	1757510-3	1757510-3
.029	[0.74]	.412	[10.46]	1.615	[41.02]	.229	[5.82]	.416	[10.57]	.479	[12.17]	.324	[8.23]	1.847	[46.91]	1.529	[38.84]	2.073	[52.65]				
.040	1.02	.432	10.97	1.093	27.76	.238	6.04	.432	10.97	.509	12.93	.334	8.48	1.317	33.45	.999	25.37	1.556	39.52	15	2	1757510-2	1757510-2
.020	[0.51]	.412	[10.46]	1.073	[27.23]	.229	[5.82]	.412	[10.46]	.479	[12.17]	.324	[8.23]	1.307	[33.20]	.989	[25.12]	1.526	[38.76]				
.040	1.02	.432	10.97	.769	19.53	.238	6.04	.432	10.97	.509	12.93	.334	8.48	.989	25.12	.671	17.04	1.228	31.19	9	1	1757510-1	1757510-1
.020	[0.51]	.412	[10.46]	.749	[19.02]	.229	[5.82]	.412	[10.46]	.479	[12.17]	.324	[8.23]	.979	[24.87]	.661	[16.79]	1.198	[30.43]				
L	J	H	G	F	E	D	C	B	A	NO OF POS	SHELL SIZE	MFG'S PART NO. ON CONNECTOR	PART NUMBER										

THIS DRAWING IS A CONTROLLED DOCUMENT.

DIMENSIONS: INCHES	TOLERANCES UNLESS OTHERWISE SPECIFIED:	DMN: C.C. THOMAS 17JAN05	APVD: D. MILLER 17JAN05	NAME: AMPLITE PLUG ASSEMBLY, SERIES 109, WITH TIN PLATED SHELLS AND GROUNDING INDENTS
0 PLC ± .0005	1 PLC ± .001	2 PLC ± .002	3 PLC ± .005	4 PLC ± .010
ANGLES ± .1°	SEE CALLOUTS	WEIGHT: —	SIZE: A1	CAGE CODE: 00779
MATERIAL: SEE CALLOUTS	FINISH: SEE CALLOUTS	RESTRICTED TO: —	SCALE: 4:1	SHEET: 1 OF 1

CUSTOMER DRAWING