

PROPER USE GUIDELINES

Cumulative trauma disorders can result from the prolonged use of manually powered hand tools. Hand tools are intended for occasional use and low-volume applications. A wide selection of powered application equipment is available for extended-use production operations.

Figure 1: PIDG PEEK STRATO-THERM terminal crimping tool

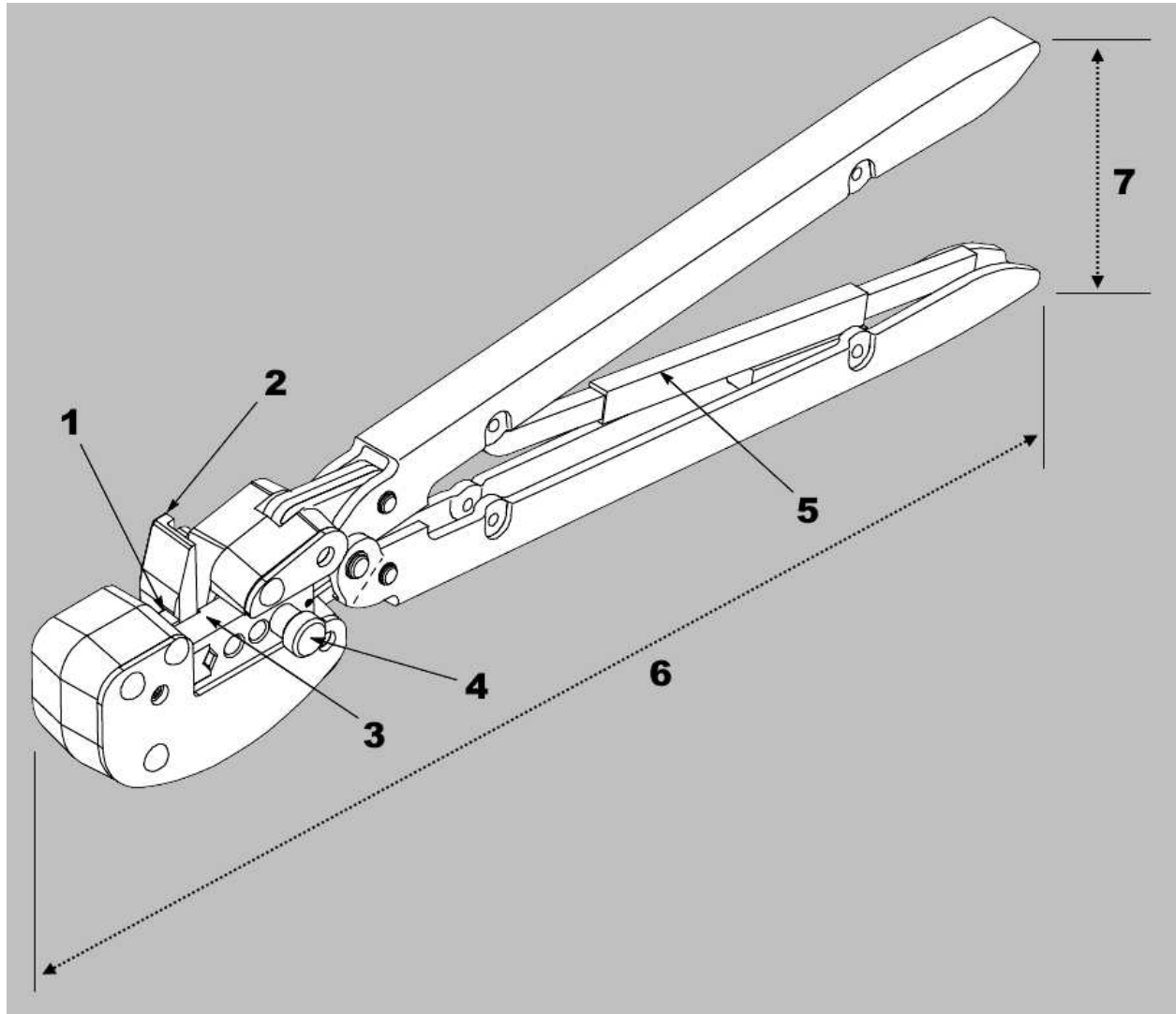

- 1** Stationary crimping dies (anvils)
- 2** Locator
- 3** Movable crimping dies (indenters)
- 4** Insulation crimping adjustment pin
- 5** Ratchet control
- 6** 304.8 mm [12.0 in.] (approximate)
- 7** 76.2 mm [3.0 in.] (approximate)

1. INTRODUCTION

This instruction sheet covers hand crimping tools 576778, 576779, 576780, 576781, 576782, 576783, and 576784, which are used to crimp PIDG PEEK STRATO-THERM Terminals to the wire sizes listed in Table 1.

Table 1: Crimping specifications

Hand tool part number	Wire size (AWG)	Dot code	Handle sticker color	Terminal color code		Strip length	
				High temp	Low temp	Min	Max
576778	24-22	2 dots	1 brown	Brown	Black	5.56 [.219]	6.35 [.250]
576779	20	1 dot	1 gray 1 purple	Gray	Purple (black stripe)		
576780	18	2 dots	1 orange	Orange	Orange (black stripe)		
576781	16	1 dot	2 orange				
576782	14	2 dots	1 white	White	White (black stripe)		
576783	12	1 dot	2 white				
576784	10	1 dot	----	Black	----	7.62 [.300]	8.38 [.330]



NOTE

Dimensions in this instruction sheet are in millimeters with [inches in brackets]. Figures are for reference only and are not drawn to scale.

Read these instructions thoroughly before crimping connectors.

2. DESCRIPTION

Each tool features a head containing two stationary crimping dies (anvils) and two movable crimping dies (indenters), a locator, an insulation crimping adjustment pin, and a CERTI-CRIMP hand crimping tool ratchet control (see Figure 1).

When the handles are closed, the crimping dies form one crimping chamber with two sections: an insulation barrel section and a wire barrel section. The insulation barrel section crimps the terminal onto the wire insulation. Simultaneously, the wire barrel section crimps the terminal wire barrel onto the stripped wire. The locator positions the terminal in the crimping chamber. The insulation crimping adjustment pin is used to regulate the height of the insulation crimp.

The CERTI-CRIMP hand crimping tool ratchet control ensures full crimping of the terminal. After it is engaged, the ratchet does not release until the tool handles are **fully** closed.



CAUTION

The dies bottom before the ratchet releases. This feature ensures maximum tensile performance of the crimp. This design feature ensures maximum electrical and tensile performance of the crimp **Do not** re-adjust the ratchet.

3. CRIMPING



NOTE

Refer to section 5 for information on insulation crimp adjustment.

1. Verify that the terminal insulation color code matches the tool handle color.
2. Select a wire of the correct size and insulation diameter for the terminal (see Table 1). **Do not** use wire with nicked or missing conductors.
3. Strip the wire to the length listed in Table 1. **Do not nick or cut wire strands.**
4. Select an applicable contact and identify the appropriate crimp section according to the wire size markings on the tool.
5. Squeeze the tool handles together until the ratchet releases and allow them to open fully.
6. Place the terminal in the dies so the wire barrel butts against the locator (Figure 2).
7. Close the handles of the tool until the contact is lightly held by the die set, but is not deformed to the point where the wire cannot enter freely.
8. Insert the wire into the crimp barrel of the contact until it butts against the locator.



CAUTION

Do not allow wire insulation to enter the terminal wire barrel.

9. While holding the wire in place, fully cycle the tool until the ratchet releases and allows the handle to open.
10. Remove the crimped terminal.
11. Examine the dot code on the finished crimp to ensure that the correct terminal and tool combination was used (Table 1).
12. Inspect the crimp as described in section 4.

Figure 2: Crimping

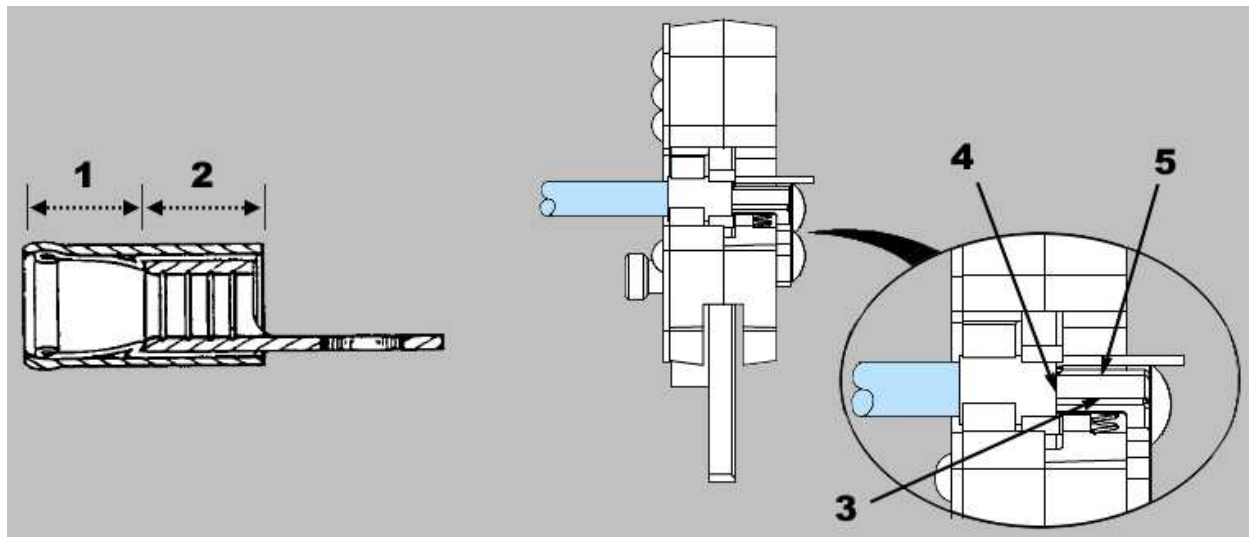

- 1 Insulation barrel
- 2 Wire barrel
- 3 Wire barrel butts against locator
- 4 End of conductor butts against locator
- 5 Locator

4. INSPECTING THE CRIMP

Inspect crimped terminals by checking the features shown in Figure 3. Poor crimps (Figure 4) can be avoided by carefully following the procedures provided in section 3, and by following the tool maintenance procedures provided in section 6.

Figure 3: Features of a good crimp

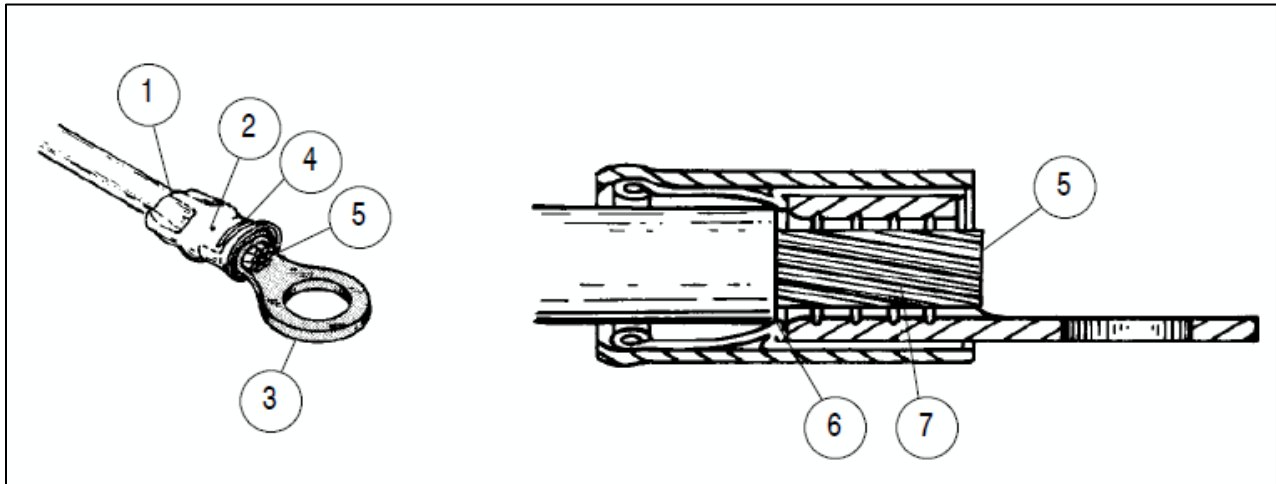

- 1** Insulation barrel is in firm contact with wire insulation.
- 2** Correct color code, dot code, and tool combination.
- 3** Wire size matches wire range or size stamped under tongue.
- 4** Crimp is centered on wire barrel.
- 5** Bare wire ends are flush with (or extend slightly beyond) end of wire barrel.
- 6** Wire insulation does not enter wire barrel.
- 7** No nicked or missing wire strands.

Figure 4: Features of a poor crimp

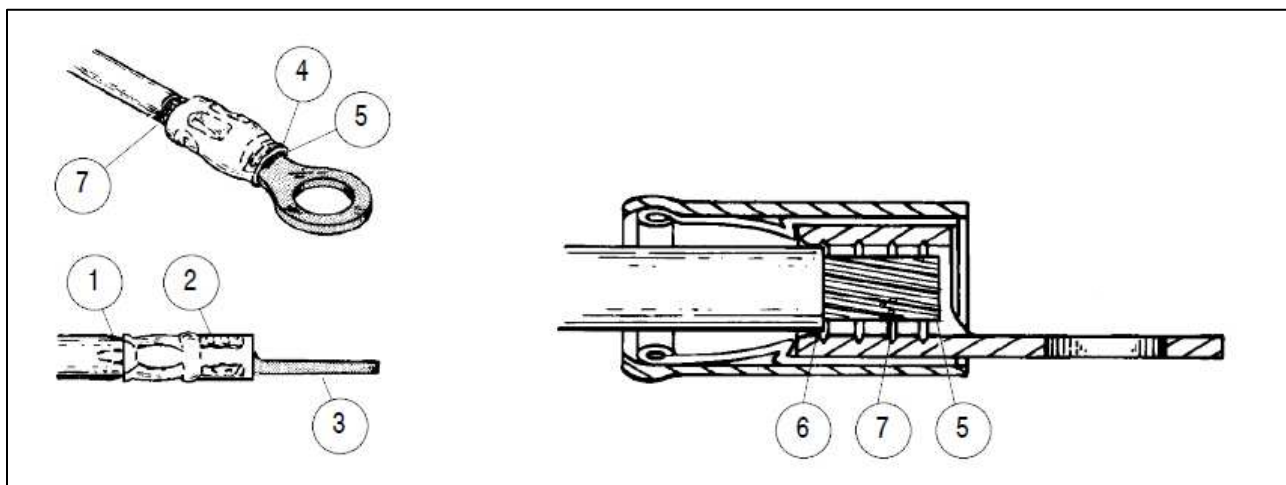

- 1** Wire insulation is extruded.
- 2** Incorrect color code, dot code, and tool combination.
- 3** Wire size does not match wire range or size stamped under tongue.
- 4** Crimp is not centered on wire barrel.
- 5** Wire not inserted far enough to reach end of wire barrel.
- 6** Wire insulation enters wire barrel. Check for incorrect strip length.
- 7** Nicked or missing wire strands.

5. ADJUSTING THE INSULATION CRIMP

The insulation crimping section of the hand tool has an adjustment pin that controls the tightness of the crimp. This pin has three positions (Figure 5).

Figure 5: Insulation crimp adjustment pin

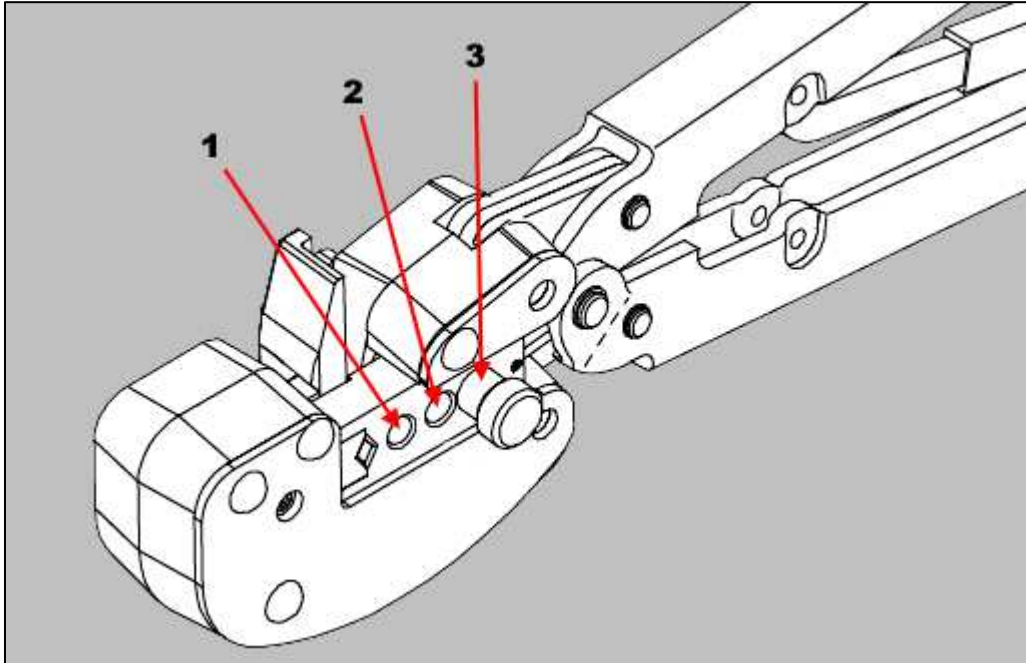

- 1** Tight
- 2** Medium
- 3** Loose

To adjust the crimp tightness, complete the following steps.

1. Insert the insulation crimp adjustment pin into the number 3 (loose) position.
2. Place the terminal into the crimping jaws (Figure 2).
3. Insert the **unstripped** wire into **only** the insulation barrel of the terminal (Figure 2).
4. Close the tool handles to complete the crimp.
5. Removed the crimped terminal and check the insulation crimp by bending the wire back and forth once. The terminal should retain its grip on the wire insulation.
6. If the wire pulls out, tighten the crimping section by setting the insulation crimp adjustment pin to the number 2 (medium) position.
7. Perform another crimp and repeat the adjustment as needed until the correct insulation grip is achieved. Do not use a tighter setting than necessary.

6. MAINTENANCE AND INSPECTION

The hand tool is inspected before being shipped. Inspect it immediately upon arrival to ensure that it was not damaged during shipment.

6.1. Daily maintenance

Make each operator of the power unit aware of, and responsible for, the following daily maintenance requirements:

- Remove dust, moisture, and other contaminants with a clean, soft brush or soft, lint-free cloth. **Do not** use objects that could damage the dies.
- Remove all lubrication and accumulated film by immersing the tool (with the handles partially closed) in a suitable commercial degreaser.
- Ensure that the retaining pins are in place and secured with retaining rings.
- Protect all pins, pivot points, and bearing surfaces with a **thin** coat of any good SAE 20 motor oil. **Do not** oil excessively.
- When the tool is not in use, keep handles closed to prevent objects from becoming lodged in the crimping jaws. Store the tool in a clean, dry area.

6.2. Lubrication

Lubricate all pins, pivot points, and bearing surfaces with SAE 20 motor oil as indicated in Table 2. Wipe excess oil from the tool, particularly from the crimping area. Oil transferred from the crimping area onto terminations can affect the electrical characteristics of an application.

Table 2: Lubrication schedule

How tool is used	When to lubricate
In daily production	Daily
Daily (occasional)	Weekly
Weekly	Monthly

6.3. Visual inspection

Regular inspections should be performed at least once per month by quality control personnel. A record of scheduled inspections should remain with the dies or be supplied to personnel responsible for the dies. Base your inspection frequency on the amount of use, ambient working conditions, operator training and skill, and established company standards. Perform the inspection as follows:

- Close the tool handles until the ratchet releases and then allow them to open freely. If they do not open quickly and fully, the spring is defective and must be replaced. See section 7, REPLACEMENT AND REPAIR.
- Inspect head assembly for worn, cracked, or broken jaws. If damage is evident, return the tool to TE for evaluation and repair. See section 7, REPLACEMENT AND REPAIR.

6.4. Crimping die closure inspection

Each tool is inspected for proper die closure before shipment. However, inspection of die closure for excessive wear is required periodically.

This inspection requires the use of plug gages conforming to the dimensions shown in Table 3 and Table 4.

Figure 6: Recommended plug gage design for wire barrel section of crimping chamber

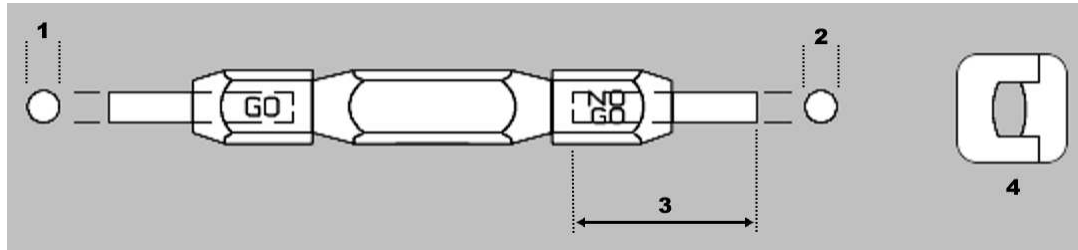

- 1 GO dimension
- 2 NO GO dimension
- 3 50.8 [2] minimum (typical)
- 4 Die closure configuration

Table 3: Plug gage dimensions for wire barrel crimping chamber

Hand tool	GO	NO GO
576778	2.591-2.598 [.1020-.1023]	2.690-2.692 [.1059-.1060]
576779	2.591-2.598 [.1020-.1023]	2.690-2.692 [.1059-.1060]
576780	3.048-3.056 [.1200-.1203]	3.147-3.150 [.1239-.1240]
576781	3.124-3.132 [.1230-.1233]	3.223-3.226 [.1269-.1270]
576782	3.327-3.335 [.1310-.1313]	3.426-3.429 [.1349-.1350]
576783	3.683-3.691 [.1450-.1453]	3.782-3.785 [.1489-.1490]
576784	4.775-4.783 [.1880-.1883]	4.874-4.877 [.1919-.1920]

Figure 7: Recommended plug gage design for insulation barrel section of crimping chamber

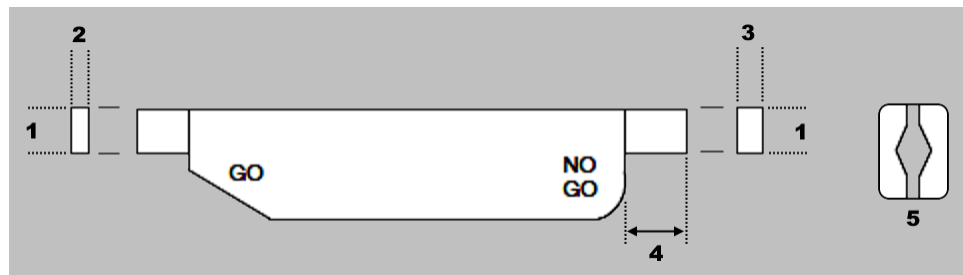

- 1 Width
- 2 GO dimension
- 3 NO GO dimension
- 4 6.35 [.250] minimum (typical)
- 5 Die closure configuration

Table 4: Plug gage dimensions for insulation barrel crimping chamber

Hand tool	GO	NO GO	Width (W)
576778	0.813-0.820 [.0320-.0323]	1.217-1.219 [.0479-.0480]	4.06 [.160]
576779	1.067-1.074 [.0420-.0423]	1.471-1.473 [.0579-.0580]	4.39 [.173]
576780	0.940-0.947 [.0370-.0373]	1.344-1.346 [.0529-.0530]	5.89 [.232]
576781	0.940-0.947 [.0370-.0373]	1.344-1.346 [.0529-.0530]	5.89 [.232]
576782	1.067-1.074 [.0420-.0423]	1.471-1.473 [.0579-.0580]	6.63 [.261]
576783	1.067-1.074 [.0420-.0423]	1.471-1.473 [.0579-.0580]	6.63 [.261]
576784	1.676-1.684 [.0660-.0663]	2.080-2.083 [.0819-.0820]	8.43 [.332]

To gage die closure, complete the following steps.

1. Remove traces of oil or dirt from the crimping chamber and plug gage.
2. Close the tool handles until the wire barrel dies are bottomed. Do not apply additional pressure to the tool handles.
3. With wire barrel dies bottomed, inspect the wire barrel crimp die closure using the proper plug gage. Press the spring-loaded locator down and hold the gage in alignment with the die closure.
4. Align the GO element with the wire barrel section of the crimping chamber (Figure 8). Push the element straight into the crimping chamber without using force. The GO element must pass completely through the crimping chamber.
5. Align the NO-GO element and try to insert it straight into the same section of the crimping chamber. The NO-GO element can start entry, but must not pass completely through the crimping chamber (Figure 8).

Figure 8: Inspecting the wire barrel crimping dies

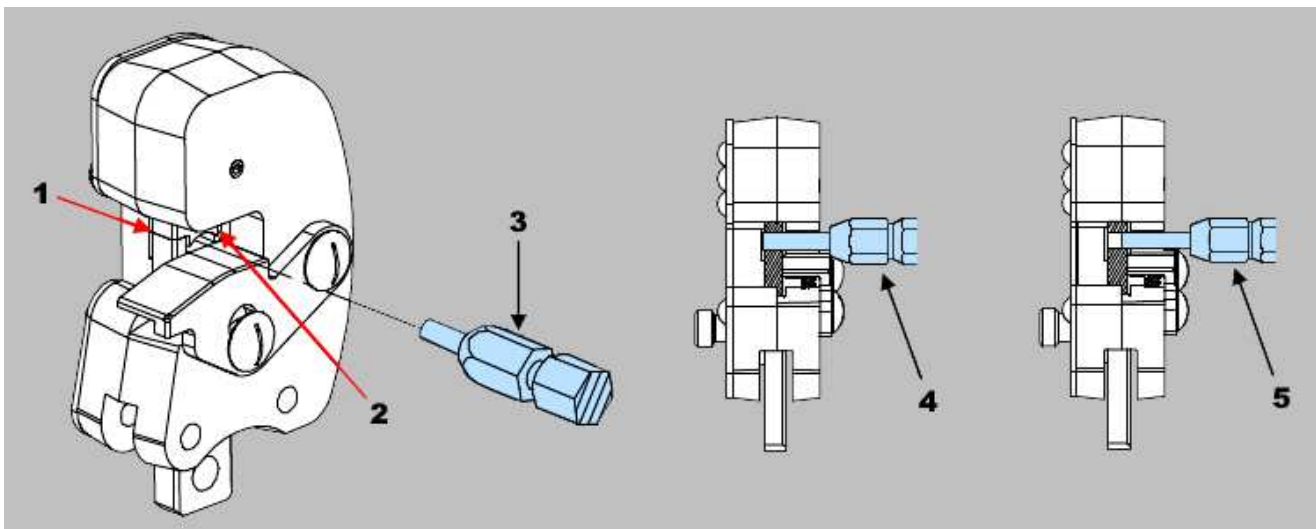

- 1 Wire barrel dies are bottomed, but not under pressure
- 2 Insert 0.025 mm [.001 in.] shim
- 3 Gage
- 4 GO gage must pass completely through the die closure
- 5 NO GO gage can enter partially, but must not pass completely through the die closure

1. Insert the insulation crimping adjustment pin in position 1 (Figure 9).
2. With the crimping dies bottomed, check the insulation barrel section of the crimping chamber (Figure 9) as described in steps 4 and 5.
 - If the crimping chamber conforms to the gage inspection, the tool is considered dimensionally correct. Lubricate it with a **thin** coat of any good SAE 20 motor oil.
 - If not, the tool must be returned to TE for further evaluation and repair. Refer to section 7, REPLACEMENT AND REPAIR.

Figure 9: Inspecting the insulation barrel crimping dies

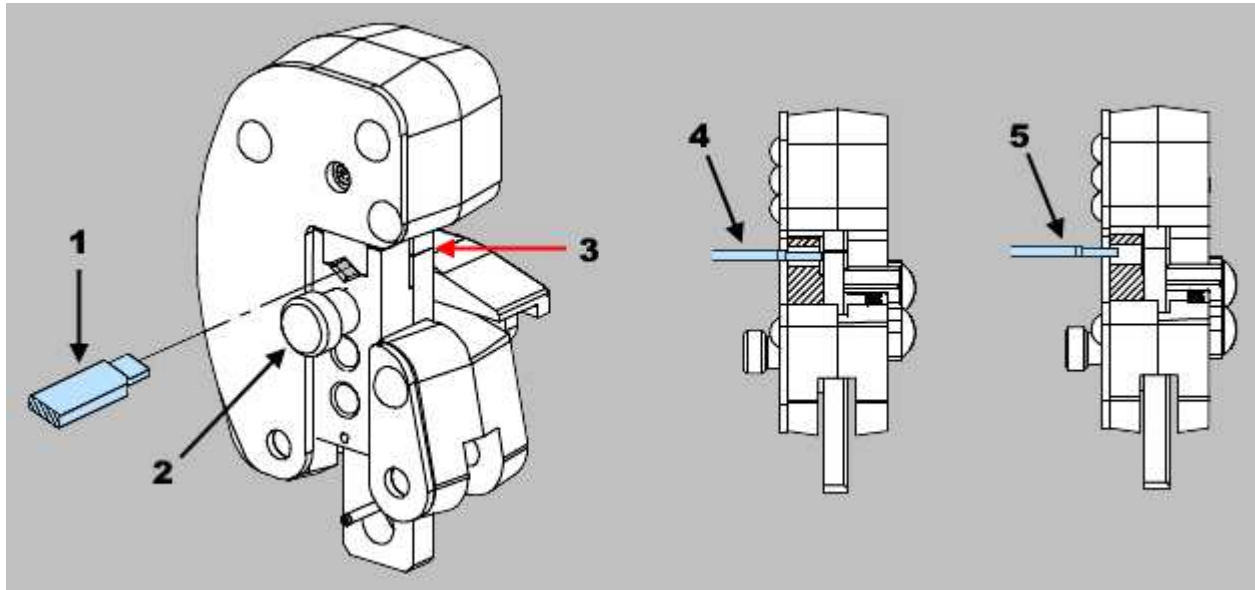

- 1 Gage
- 2 Adjustment pin in position 1
- 3 Wire barrel dies are bottomed, but not under pressure
- 4 GO gage must pass completely through the die closure
- 5 NO GO gage can enter partially, but must not pass completely through the die closure

For additional information regarding the use of plug gages, refer to instruction sheet [408-7424](#).

6.5. Inspecting the ratchet control

The CERTI-CRIMP hand crimping tool ratchet control feature on TE hand tools must be checked to ensure that the ratchet does not release prematurely, allowing the dies to open before they have fully bottomed.

1. Obtain a 0.025 mm [.001 in.] shim that is suitable for checking the clearance between the bottoming surfaces of the crimping dies.
2. Select the maximum size wire for the tool and a terminal.
3. Position the terminal and wire between the crimping dies as described in section 3.
4. While holding the wire in place, squeeze the tool handles until the CERTI-CRIMP hand crimping tool ratchet control releases. Hold the handles in this position, maintaining just enough tension to keep the dies closed.
5. Check the clearance between the bottoming surfaces of the crimping dies with the 0.025 mm [.001 in.] shim.
 - If the clearance is 0.025 mm [.001 in.] or less, the ratchet is considered satisfactory.
 - If the clearance exceeds 0.025 mm [.001 in.], the ratchet is out of adjustment and must be repaired.

7. REPLACEMENT AND REPAIR

Replaceable parts are listed in Figure 7. Parts other than those listed in Figure 7 should be replaced by TE to ensure quality and reliability of the tool. Order replacement parts through your TE representative. You can also order parts by any of the following methods:

- Go to TE.com and click the **Shop TE** link at the top of the page.
- Call 800-522-6752.
- Write to:

CUSTOMER SERVICE (038-035)
 TE CONNECTIVITY CORPORATION
 PO BOX 3608
 HARRISBURG PA 17105-3608

For customer repair services, call 800-522-6752.

Figure 10: Replaceable parts

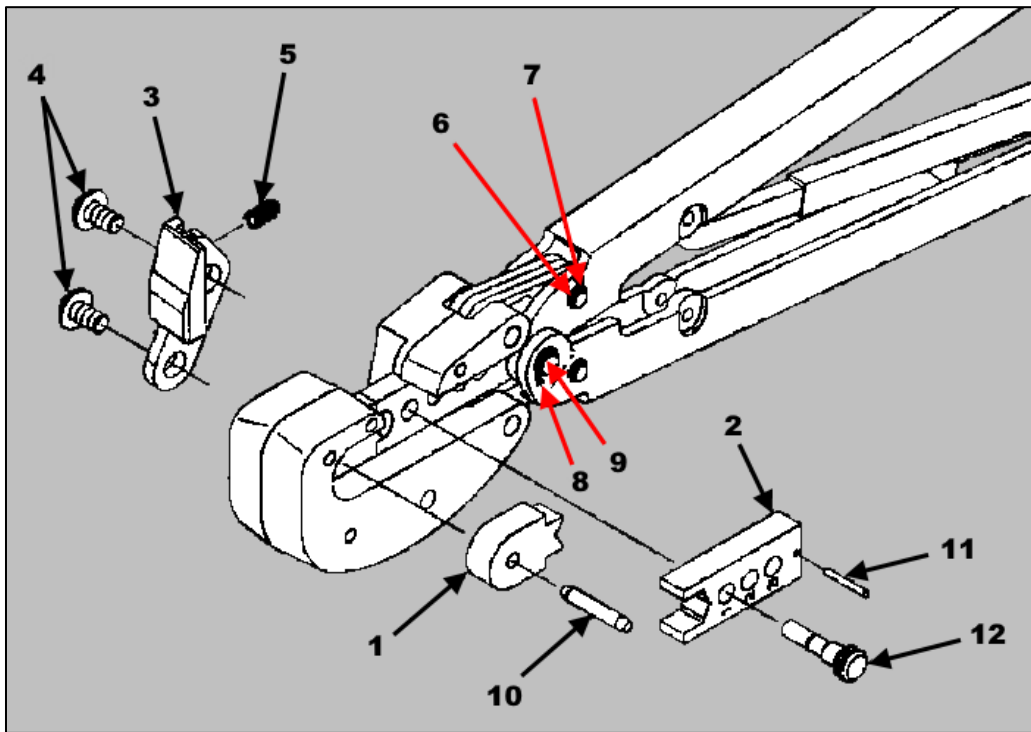

Table 5: Part numbers

Item	Description	Quantity per tool	576778	576779	576780	576781	576782	576783	576784
1	Stationary insulation die	1	576788	576788-1	576788-2		576788-3		576788-4
2	Moving insulation die	1	576785	576785-1	576785-2		576785-3		576785-4
3	Stop locator	1	1901238-1		1901238-2				1901238-3
4	Screw	2				59580-6			
5	Spring	1				7-59683-6			
6	Retaining ring	4				525108			
7	Retaining pin	2				300388			
8	Retaining ring	2				21045-6			
9	Retaining pin	1				300389			
10	Pin	1				5-21028-7			
11	Pin	1				21028-4			
12	Adjustment pin	1				1752891-1			

8. REVISION SUMMARY

Revisions to this instruction sheet include:

- Reformatted to current standard for instruction sheets
- Updated handle sticker colors in Table 1