

| COUNT | DESCRIPTION OF REVISIONS | BY | CHKD | DATE | COUNT | DESCRIPTION OF REVISIONS | BY | CHKD | DATE |
|-------|--------------------------|----|------|------|-------|--------------------------|----|------|------|
| △ | | | | | △ | | | | |
| △ | | | | | △ | | | | |
| △ | | | | | △ | | | | |

| COUNT | DESCRIPTION OF REVISIONS | BY | CHKD | DATE |
|-------|--------------------------|----|------|------|
| △ | | | | |
| △ | | | | |
| △ | | | | |

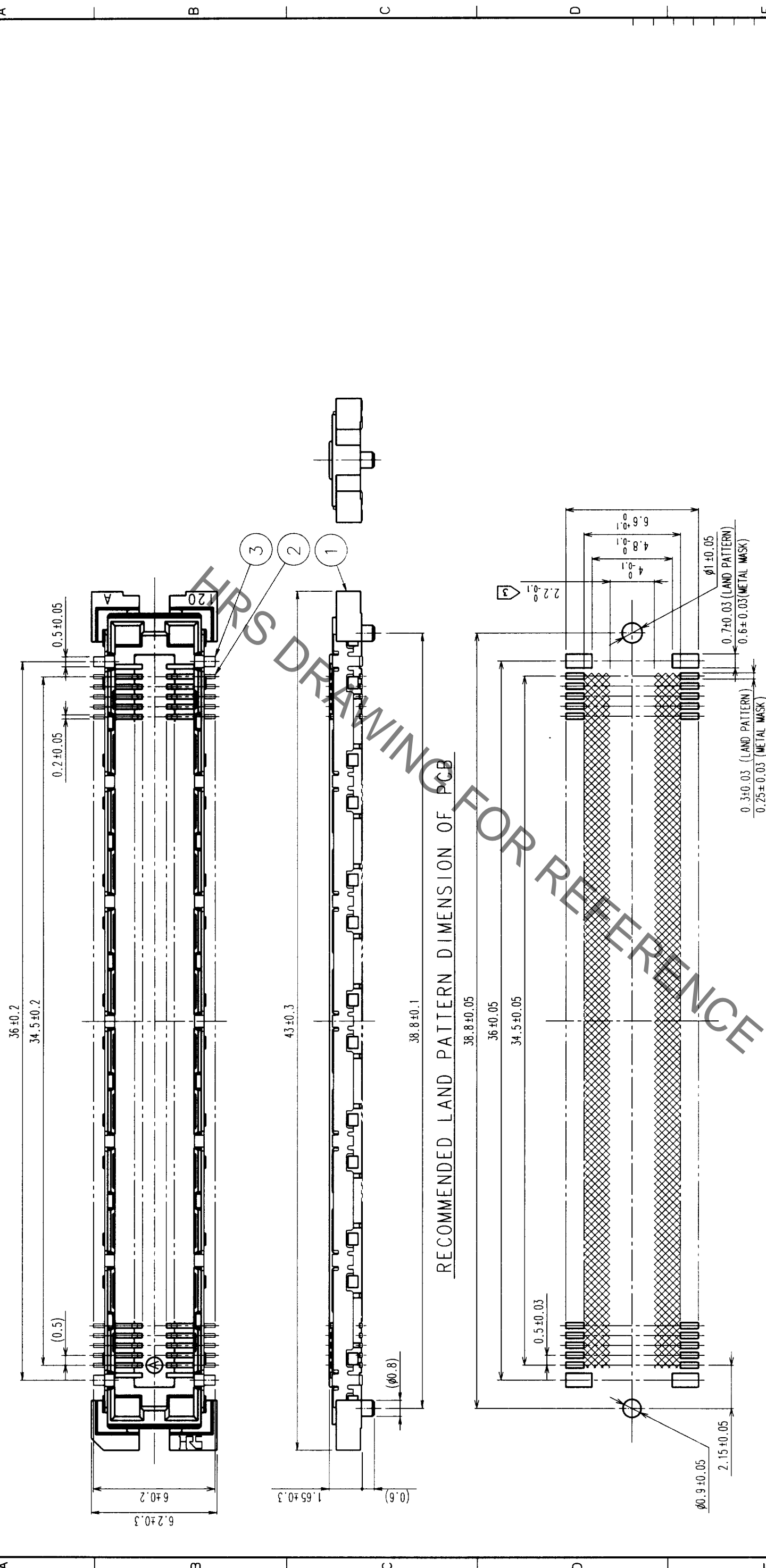

- NOTES
- SMT LEAD-COPLANARITY: 0.1 MAX.
 - THIS PRODUCT HAS NO POLARITY TO PATTERN FOR MOUNTING.
 - MAKE SURE WIDTH OF PATTERN IS WITHIN THAT OF LAND, OR LEAD MAY TOUCH PATTERN. (THIS APPLIES TO HATCHED AREA.)
 - TO BE EMBOSSED CARRIER TAPED AS SPECIFIED IN SHEET 2.

| NO. | MATERIAL | FINISH, REMARKS | NO. | MATERIAL | FINISH, REMARKS |
|-----|-----------------|--|-----|-----------------|-----------------|
| 2 | PHOSPHOR BRONZE | CONTACT AREA: GOLD (0.1µm) OVER NICKEL | 3 | PHOSPHOR BRONZE | TIN PLATED |
| 1 | LCP | BEIGE UL94V-0 | | | |

| CODE NO. (OLD) | CL | DRAWN | DESIGNED | CHECKED | APPROVED | RELEASED |
|----------------|----|-------|----------|---------|----------|----------|
| | | | | | | |

| DRAWING NO. | PART NO. |
|----------------|---------------------|
| EDC3-152119-01 | FX11LA-140S-SV (21) |

| SCALE | UNITS | CODE NO. |
|-------|-------|-----------------|
| 5 : 1 | mm | CL573-0145-4-21 |

| | |
|-----|--|
| TO | |
| PCK | |

1 2 3 4 5 6 7 8

| COUNT | DESCRIPTION OF REVISIONS | BY | CHKD | DATE | COUNT | DESCRIPTION OF REVISIONS | BY | CHKD | DATE |
|-------|--------------------------|----|------|------|-------|--------------------------|----|------|------|
| △ | | | | | △ | | | | |
| △ | | | | | △ | | | | |
| △ | | | | | △ | | | | |

REELED DIMENSION (Free)

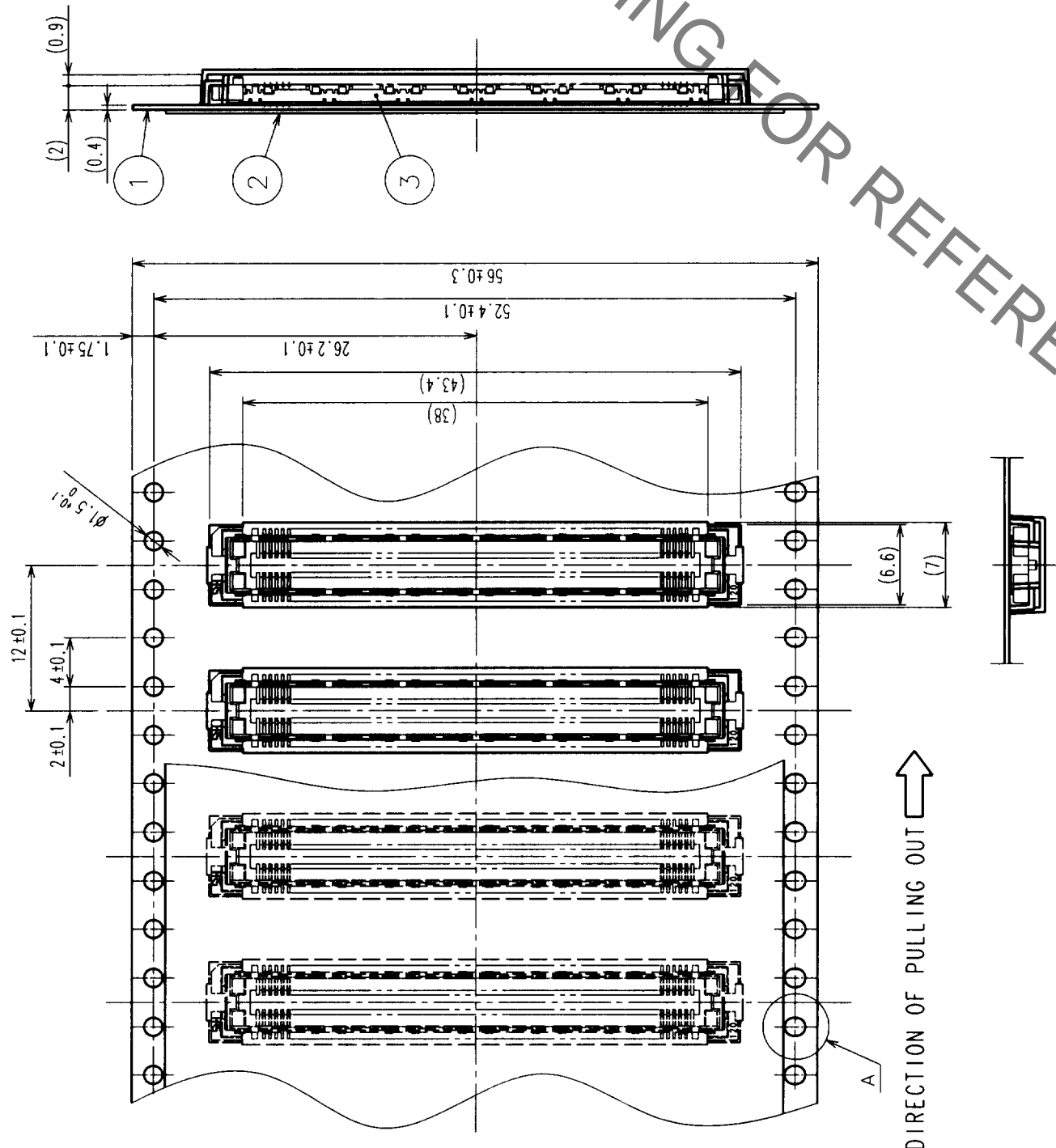
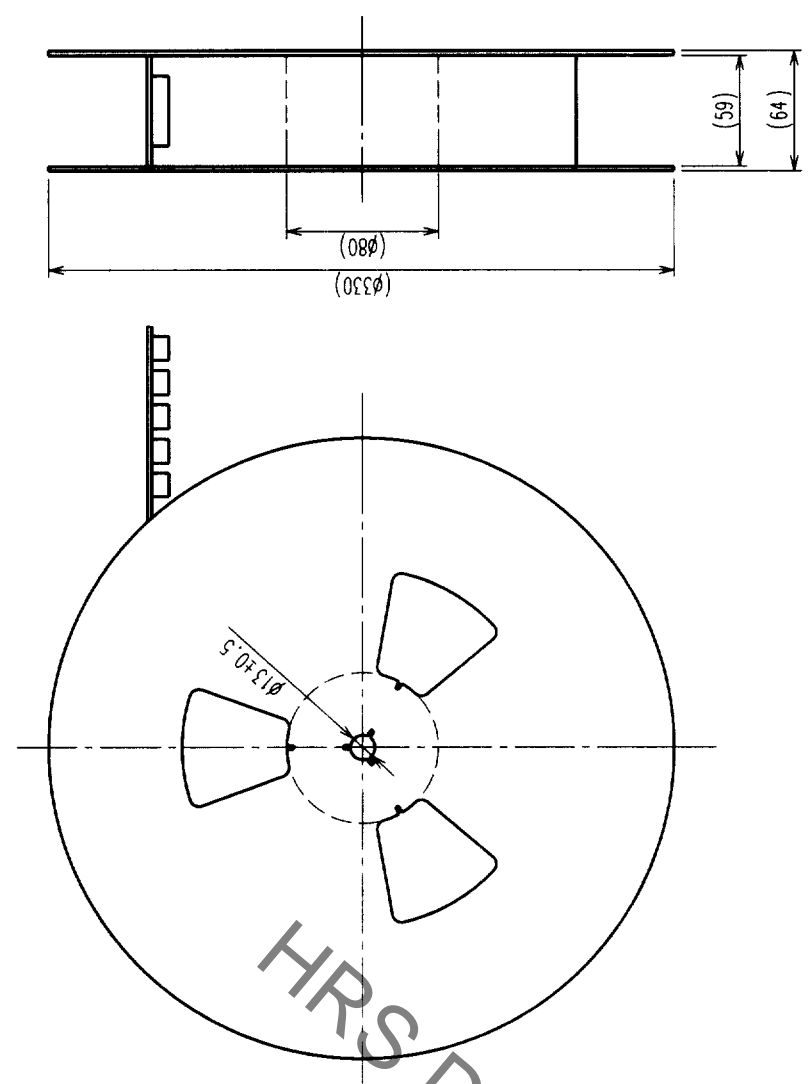

A (5:1)

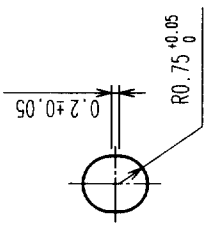

- NOTES
- 1 REEL: 1000 CONNECTORS.
 - 2 MINIMUM 10 COMPARTMENTS FROM BOTH REEL ENDS REMAIN EMPTY.
 - 3 THIS PRODUCT HAS NO POLARITY TO TAPE AND REEL PACKAGING.

| 2 | | TOP COVER TAPE | | 3 | | (CONNECTOR) | |
|---------------------|----------|-----------------------|----------------|--------------------------|-----------------|-----------------|----------------|
| 1 | | EMBOSSED CARRIER TAPE | | 3 | | | |
| NO. | MATERIAL | FINISH, REMARKS | NO. | MATERIAL | FINISH, REMARKS | APPROVED | RELEASED |
| CODE NO. (OLD) | CL | | DRAWN | DESIGNED | CHECKED | | |
| | | | <i>Mitsuru</i> | <i>Mitsuru</i> | <i>Mitsuru</i> | <i>Mitsuru</i> | <i>Mitsuru</i> |
| | | | 99.10.25 | 99.10.25 | 99.10.26 | 99.10.26 | 99.10.26 |
| DRAWING FOR PACKING | | DRAWING NO. | | PART NO. | | | |
| SCALE | | EDC3-152119-01 | | FX11LA-140S-SV(21) | | | |
| UNITS | | 2 : 1 | | CODE NO. | | CL573-0145-4-21 | |
| | | mm | | HIROSE ELECTRIC CO., LTD | | | |

| | |
|-----|--|
| TO | |
| PCK | |
| | |
| | |

1 2 3 4 5 6 7 8