

COUNT	DESCRIPTION OF REVISIONS	BY	CHKD	DATE	COUNT	DESCRIPTION OF REVISIONS	BY	CHKD	DATE
2	RE-J-01958	K.HIDA	K.K.	02.11.25					

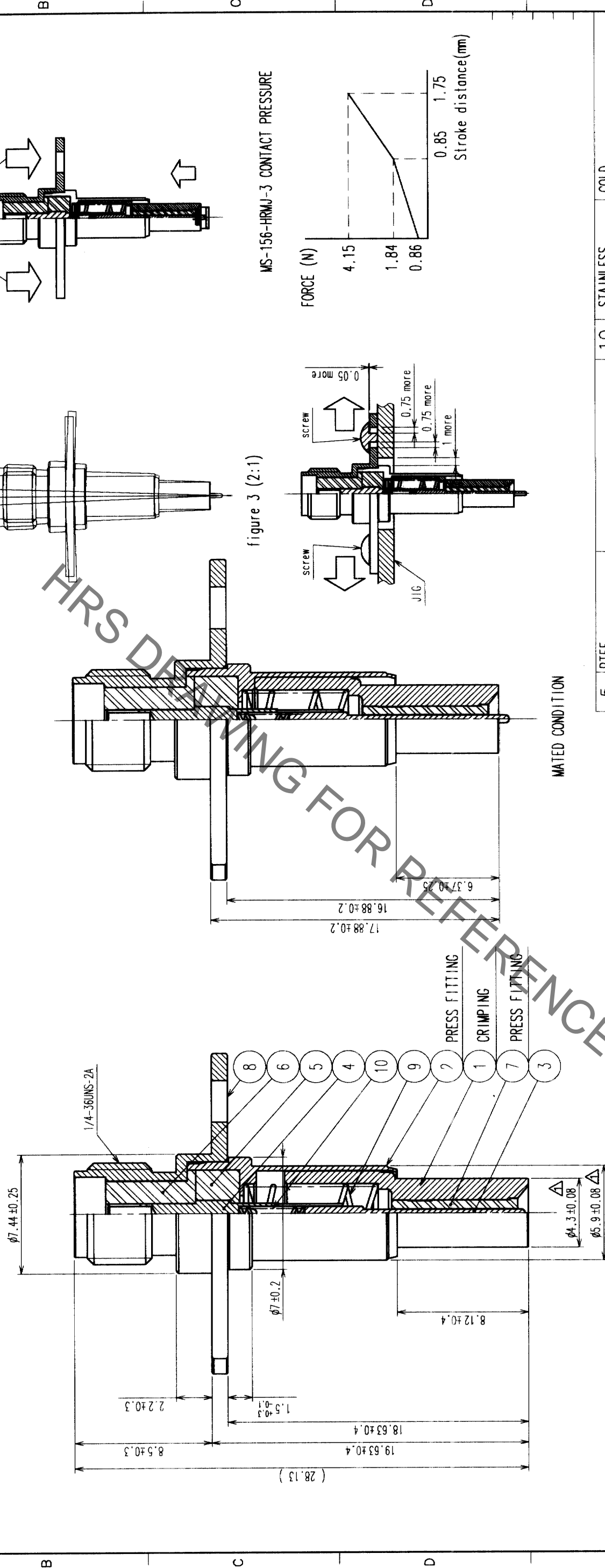

NO.	MATERIAL	FINISH	REMARKS	NO.	MATERIAL	FINISH	REMARKS
5	PTFE			10	STAINLESS		GOLD
4	BERYLLIUM COPPER	GOLD		9	STAINLESS		
3	BERYLLIUM COPPER	GOLD		8	STAINLESS		PASSIVATE
2	BERYLLIUM COPPER	GOLD		7	PTFE		
1	BERYLLIUM COPPER	GOLD		6	PTFE		

CODE NO. (OLD)	DRAWN	DESIGNED	CHECKED	APPROVED	RELEASED
	K.HIDA	K.HIDA	K.KAWAMURA	Y.MIYAKE	
	'02.11.1	'02.11.1	'02.11.5	'02.11.5	

DRAWING NO.	EDC3-180317	PART NO.	MS-156-HRMJ-6
SCALE	4 : 1	CODE NO.	CL358-0181-9
UNITS	MM		

figure 1 (2:1)

TOTAL 6 TO 10N

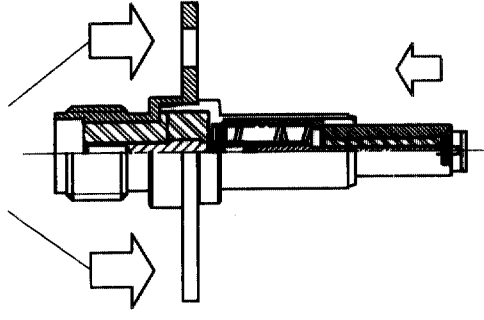
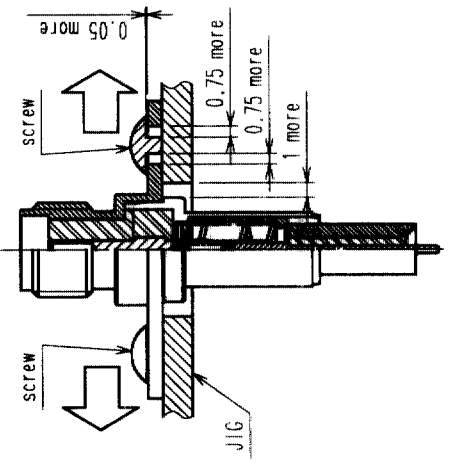
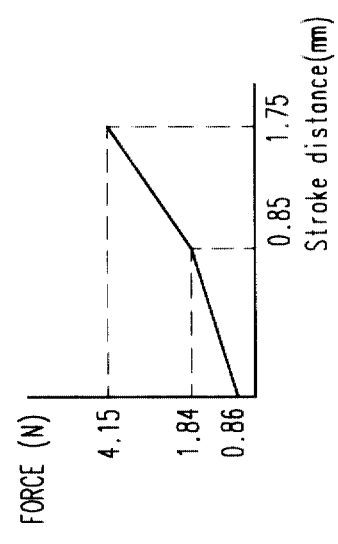

figure 3 (2:1)



MS-156-HRMJ-3 CONTACT PRESSURE



NOTE 1. This adaptor must be pushed on the receptacle (MS-156) with 6 to 10N. (refer to figure 2)
 2. Mating angle must be less than ±2 degree. (refer to figure 1)
 3. This product should not be fixed completely so that it keep space to align for connection. If your jig have alignment structure, it is not needed.
 4. Recommended setting configuration is shown in figure 3.

TO	
RFD	