



---

## HMN-D3-2/6-M and HMN-D3-2/6-F Insert Series

### Table of contents

1.	INTRODUCTION .....	2
2.	SUPPORTING DOCUMENTS .....	2
2.1.	Customer drawings .....	2
2.2.	Product specification .....	2
2.3.	Application Specification .....	2
2.4.	Standards .....	2
3.	DESCRIPTION .....	3
4.	REQUIREMENTS .....	4
4.1.	Intercontec connector 2-pin Ethernet preparation .....	4
4.2.	Intercontec connector 6-pin Ethernet preparation .....	5
4.3.	Intercontec connector into module inserts .....	6
5.	ASSEMBLY .....	7
5.1.	Contact inserts .....	7
5.2.	Grounding .....	8
5.3.	Marking .....	9
5.4.	Polarization function .....	9
6.	STORAGE .....	10
6.1.	Chemical exposure .....	10
6.2.	Storage condition .....	10



## 1. INTRODUCTION

This specification contains the regulations for assembly of HMN-D3-2/6-M/F contact inserts and the handling of these inserts.

## 2. SUPPORTING DOCUMENTS

### 2.1. Customer drawings

Please refer to the customer drawings of HMN-D3-2/6-M/F insert series.

### 2.2. Product specification

The product specifications of the used articles are to be taken into account. The product specification describes the technical data as e.g. regulations, approvals, temperature range and rated voltage.

For further reference refer Product spec. 108-137419.

### 2.3. Application Specification

Connectors shall be assembled as below mentioned application specifications to ensure correct connector assembly.

### 2.4. Standards

- EN 61984: Connectors - Safety requirements and tests
- IEC 60664-1: Insulation coordination for equipment within low-voltage systems (Part 1)

## 3. DESCRIPTION

This application specification describes the male module insert and the female module insert of the HMN-D3-2/6-M/F series.

The listed terms are used in the specification as shown HMN-D3-2/6-M/F with H24BN module frame as example in figure 1.

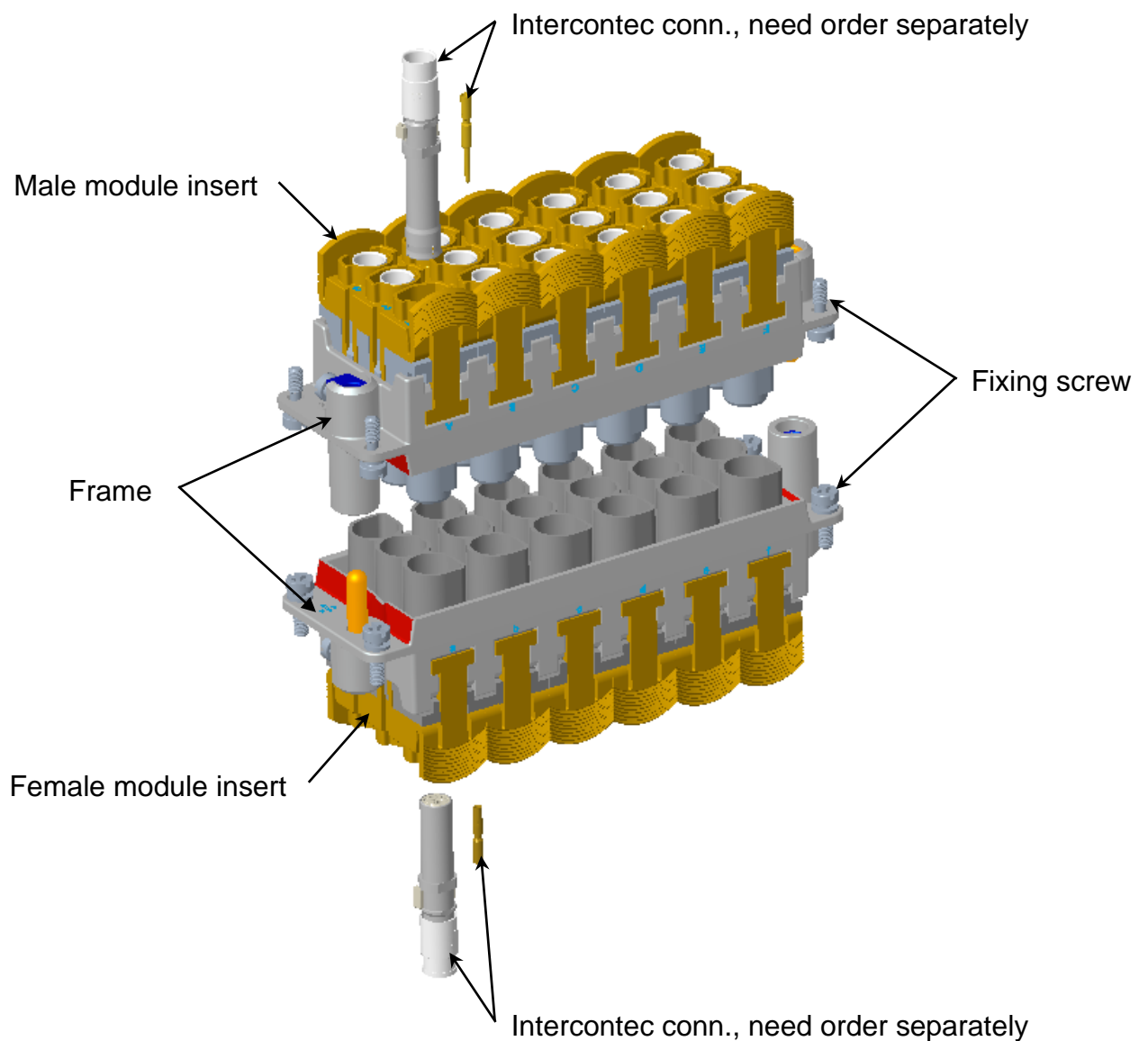
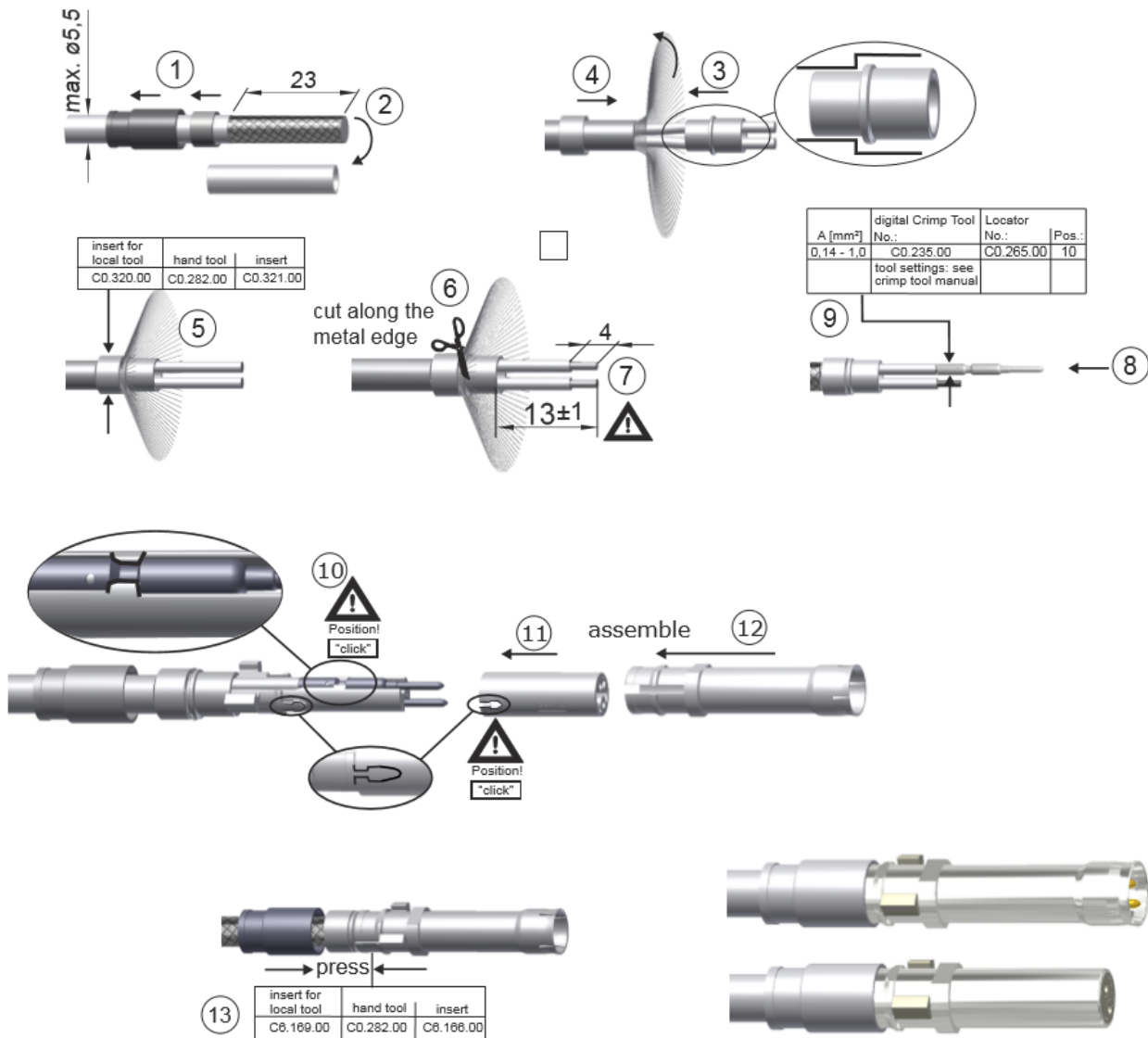

**Figure: 1**

## 4. REQUIREMENTS

### 4.1. Intercontec connector 2-pin Ethernet preparation

Refer below application for 2-pin Ethernet.



## 4.2. Intercontec connector 6-pin Ethernet preparation

Refer below application for 6-pin Ethernet.

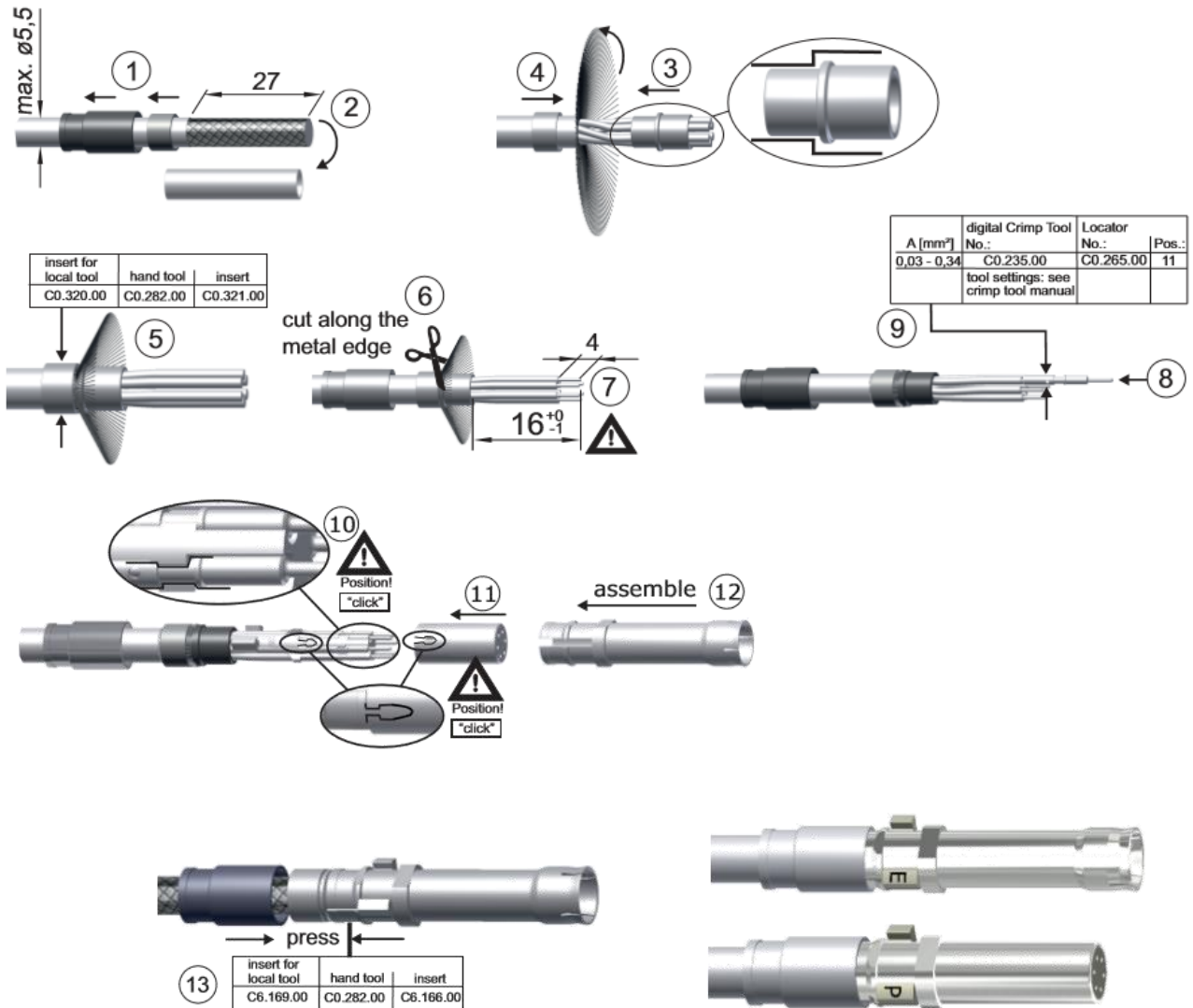

## 4.3. Intercontec connector into module inserts

The Intercontec connector 2-pin or 6-pin are plugged into the module insert by gently pushing it into the required position until the contact is locked by the inserts, a click should be heard normally.

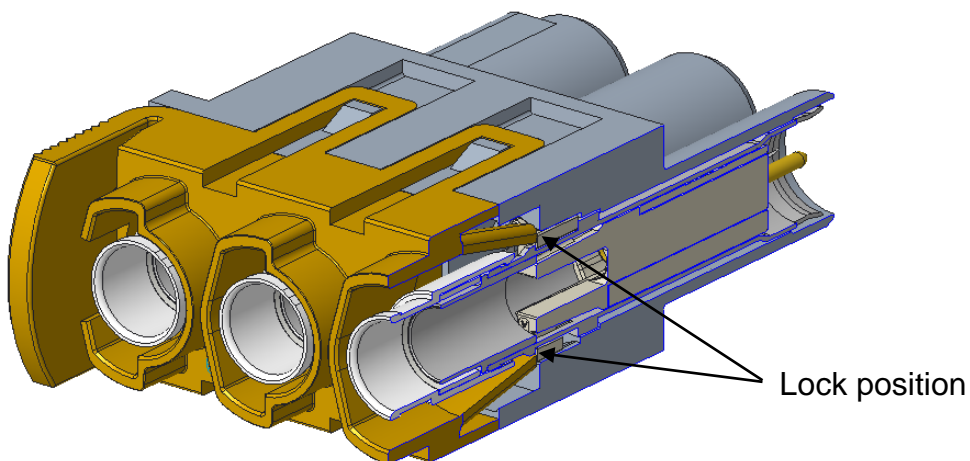
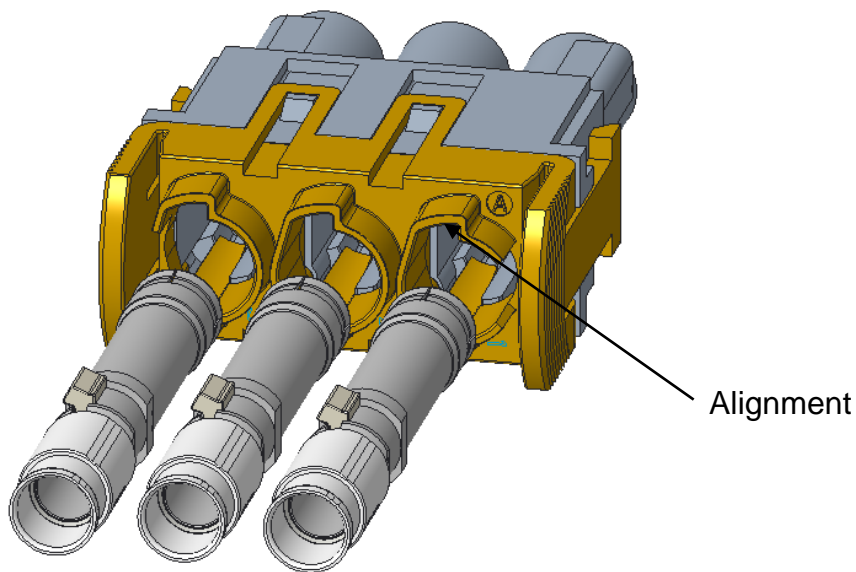

## 5. ASSEMBLY

Assembling the contact inserts for both Male & Female connector has to be carried out with proper tools.

### 5.1. Contact inserts

The contact inserts are screwed into a corresponding hood or housing by fixing screws M3. The torque is 0.5Nm for reference.

Note: \* The distance for safe contact of the contact inserts is max. 21mm. See figure 2.

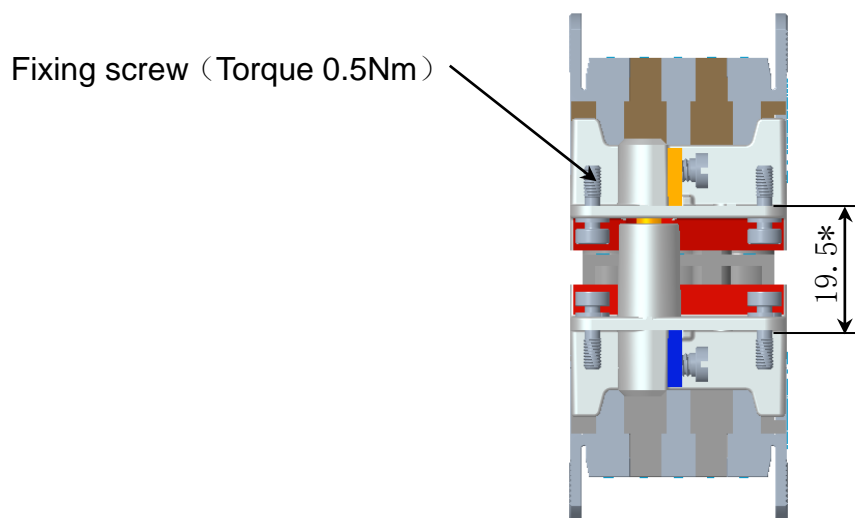

**Figure: 2**

## 5.2. Grounding

This clamping point is suitable for connection of a cable with a nominal cross section of up to 4 mm<sup>2</sup>. Earthing is to be executed according to IEC 61984. The strip length of cable for PE connection: 8+/-0.5 mm.

Ferules and blade terminals can be used for ground connection.

Tighten torque are shown in below table 2 as reference.

**Table: 2**

Wire gauge (mm <sup>2</sup> )	1.5	2.5	4
Tighten torque (Nm)	0.5	0.5	0.8
Min. pull-out for stranded wire (N)	40	50	60

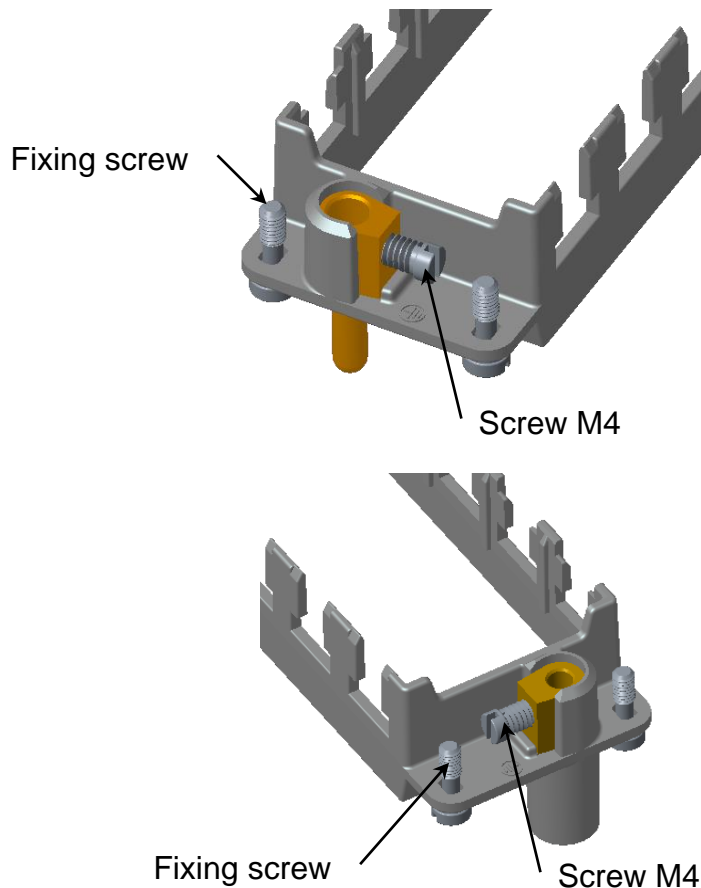

**Figure: 3**



## 5.3. Marking

The connector type, rating and the number of position etc. refer to the corresponding HMN-D3-2/6-M/F module insert customer drawings.

## 5.4. Polarization function

The process of assembling the male and female module inserts without any mismatch and difficulty calls for polarization. This is done with the help of ribs or slots and which are present on both the male module insert as well as the female module insert. As shown in figure 4.

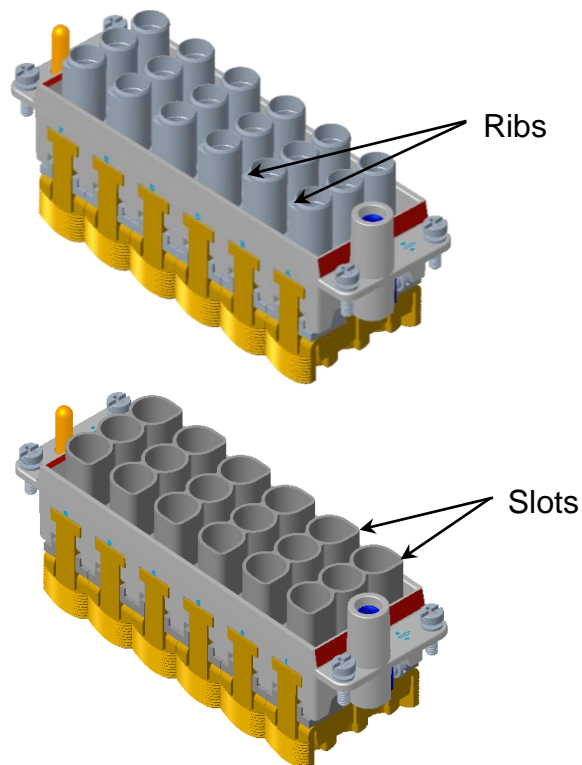

**Figure: 4**



## 6. STORAGE

### 6.1. Chemical exposure

Do not store the connectors near any chemical listed below as they may cause corrosion stress the connector contacts:

Alkalies, Ammonia, Citrates, Phosphates, Citrates, Sulfur, Amines, Carbonates, Nitrites, Sulfides, Nitrites, Tart rates.

### 6.2. Storage condition

The connectors should be stored in the air ventilation, no corrosive gas, no rain and no snow in the warehouse. Relative humidity: less than 85% RH. The connectors should remain in the shipping containers until ready for use to prevent deformation to the contacts. The connectors should be used on a first in, first out basis to avoid storage contamination that could adversely affect electrical functions.

-----END-----