

THIS DOCUMENT IS THE PROPERTY OF KEYSTONE ELECTRONICS CORP. AND SHALL NOT BE REPRODUCED, DISTRIBUTED OR USED AS A BASIS FOR MANUFACTURE WITHOUT PRIOR WRITTEN PERMISSION FROM KEYSTONE ELECTRONICS CORP.

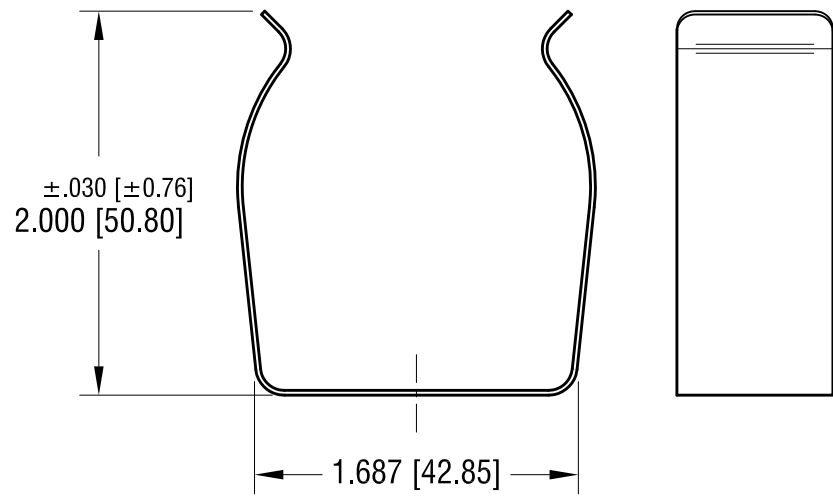
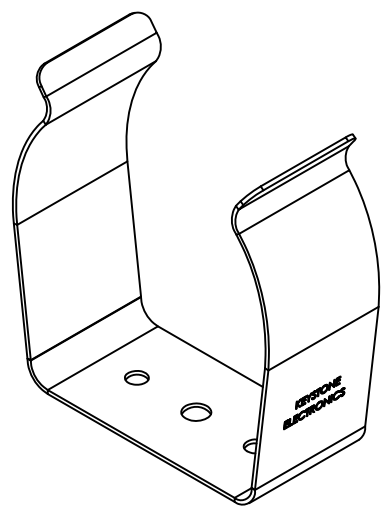
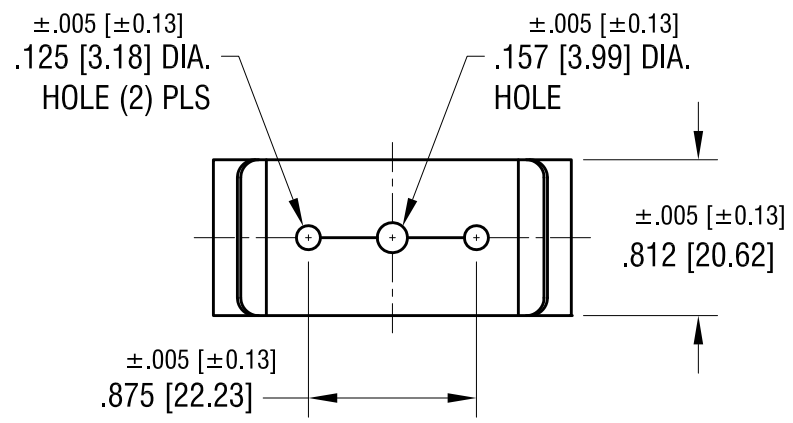

NOTE:
1. HEAT TREAT TO SPRING TEMPER.

KEYSTONE ELECTRONICS CORP.			
www.keyelco.com • NEW HYDE PARK NY 11040 • Tel (516)328-7500			
PART NAME		COMPONENT CLIP	
MATERIAL			
.025 [0.63] TH'K ANNEALED SPRING STEEL			
FINISH		DRN BY	DATE
NICKEL PLATE		BOONE	2.03.82
		APP'D	SCALE
		RH	1X
4.10.03	CHANGE AS PER ECN 03-031	D	
DATE	DESCRIPTION	REV.	
TOLERANCES INCH [MM]		CODE	DWG NO.
DECIMAL $\pm .010$ [± 0.25]		C	
ANGULAR $\pm 1^\circ$			
UNLESS OTHERWISE SPECIFIED			
			219

4.10.03	CHANGE AS PER ECN 03-031	D
DATE	DESCRIPTION	REV.