

May.1.2023 Copyright 2023 HIROSE ELECTRIC CO., LTD. All Rights Reserved.
In case of consideration for using Automotive equipment / device which demand high reliability, kindly contact our sales window correspondents.

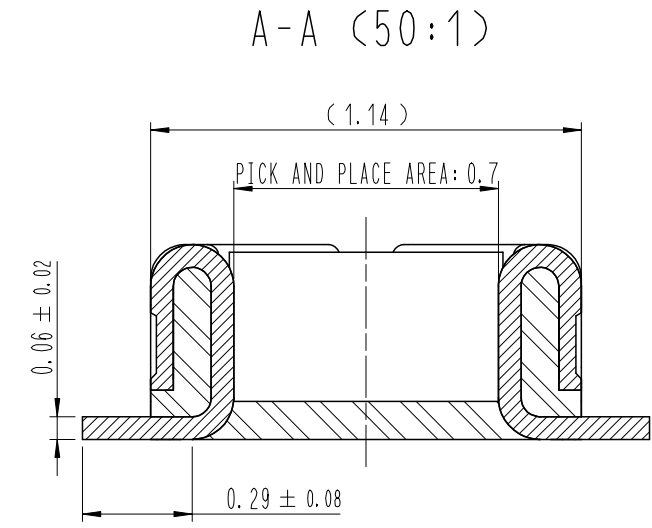

ENGAGEMENT FIGURE (50:1)

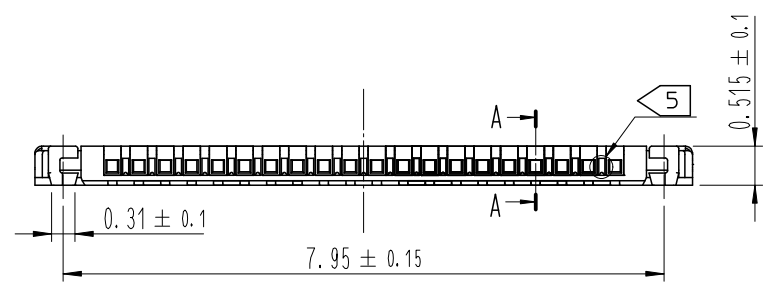
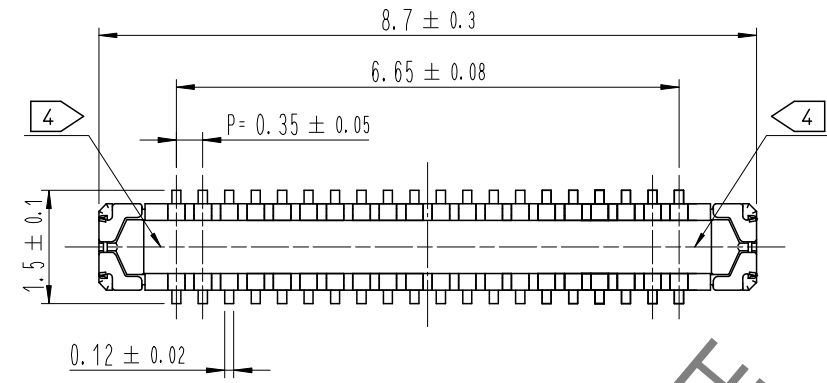
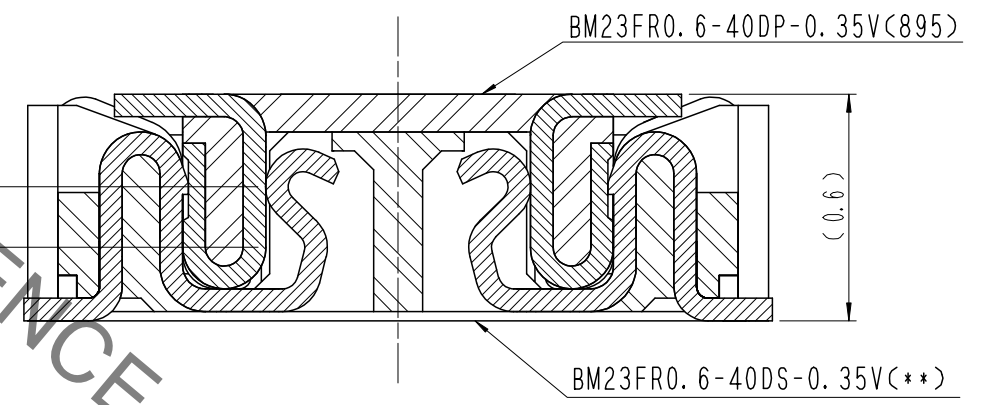

DRAWING FOR REFERENCE
This is subject to change without notice

- NOTE
- 1. ALL LEAD CO-PLANARITY SHALL BE 0.08mm MAX.
 - 2. CONTACT PLATING SPECIFICATIONS.
CONTACT AREA : GOLD 0.05 μm MIN.
SMT LEAD : GOLD 0.05 μm MIN.
UNDER PLATING : NICKEL 1 μm MIN.
(SURFACE : SEALING)
 - 3. METAL FITTING PLATING SPECIFICATIONS.
SMT LEAD : GOLD 0.05 μm MIN.
UNDERPLATING : NICKEL 1 μm MIN.
(SURFACE : SEALING)
 - 4. HRS MARK and CAV No. IS INDICATED IN APPROX POSITION SHOWN.
 - 5. A PART OF THE WALL COULD BE NOTCHED.

COUNT	DESCRIPTION OF REVISIONS	B	Y	CHKD	DATE	COUNT	DESCRIPTION OF REVISIONS	B	Y	CHKD	DATE
△						△					
△						△					
△						△					

NO.	MATERIAL	FINISH , REMARKS	NO.	MATERIAL	FINISH , REMARKS
4	PS	CLEAR (EMBOSSED CARRIER TAPE)	7	PS	CLEAR (REINFORCEMENT COLLAR)
3	COPPER ALLOY	3	6	PS	BLACK (PLASTIC REEL)
2	COPPER ALLOY	2	5	POLYESTER	CLEAR (COVER TAPE)
1	LCP	UL94 V-0, BLACK			

REMARKS					DRAWN	DESIGNED	CHECKED	APPROVED	RELEASED
					S. H. JUNG	S. H. JUNG	H. W. JO	T. S. KANG	17.05.08
					17.05.08	17.05.08	17.05.08	17.05.08	17.05.08

CODE NO. (OLD)	DRAWING NO. EDC3-632176	PART NO. BM23FR0.6-40DP-0.35V(895)
SCALE 10:1	HRS HIROSE KOREA CO., LTD.	CODE NO CL 6644-0082-9-895
UNITS mm		1/3

May.1.2023 Copyright 2023 HIROSE ELECTRIC CO., LTD. All Rights Reserved.
In case of consideration for using Automotive equipment / device which demand high reliability, kindly contact our sales window correspondents.

7 RECOMMENDED PCB LAYOUT

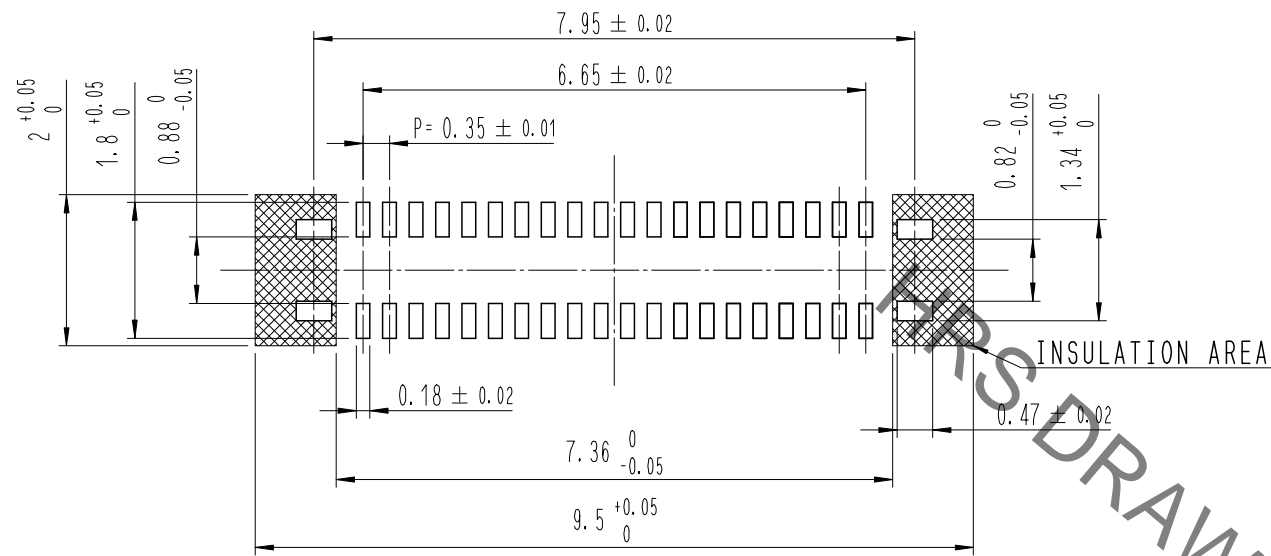

RECOMMENDED METAL MASK DIMENSIONS

METAL MASK THICKNESS : 100 μm

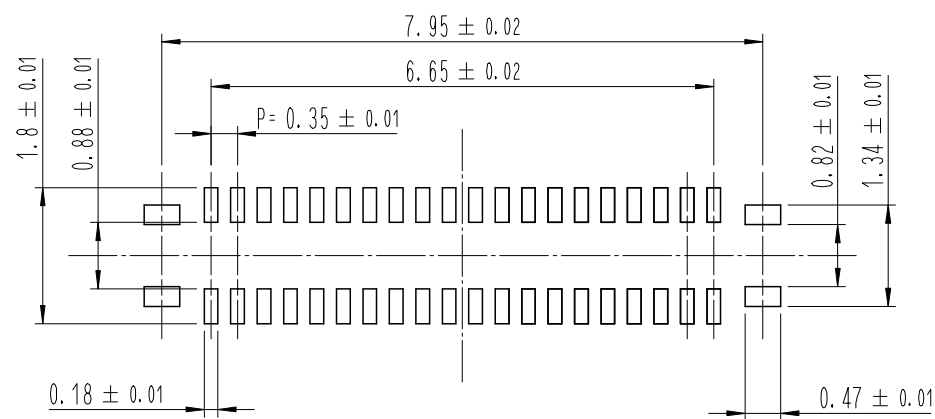

6 RECOMMENDED REFLOW TEMPERATURE PROFILE USING LEAD-FREE SOLDER PASTE.

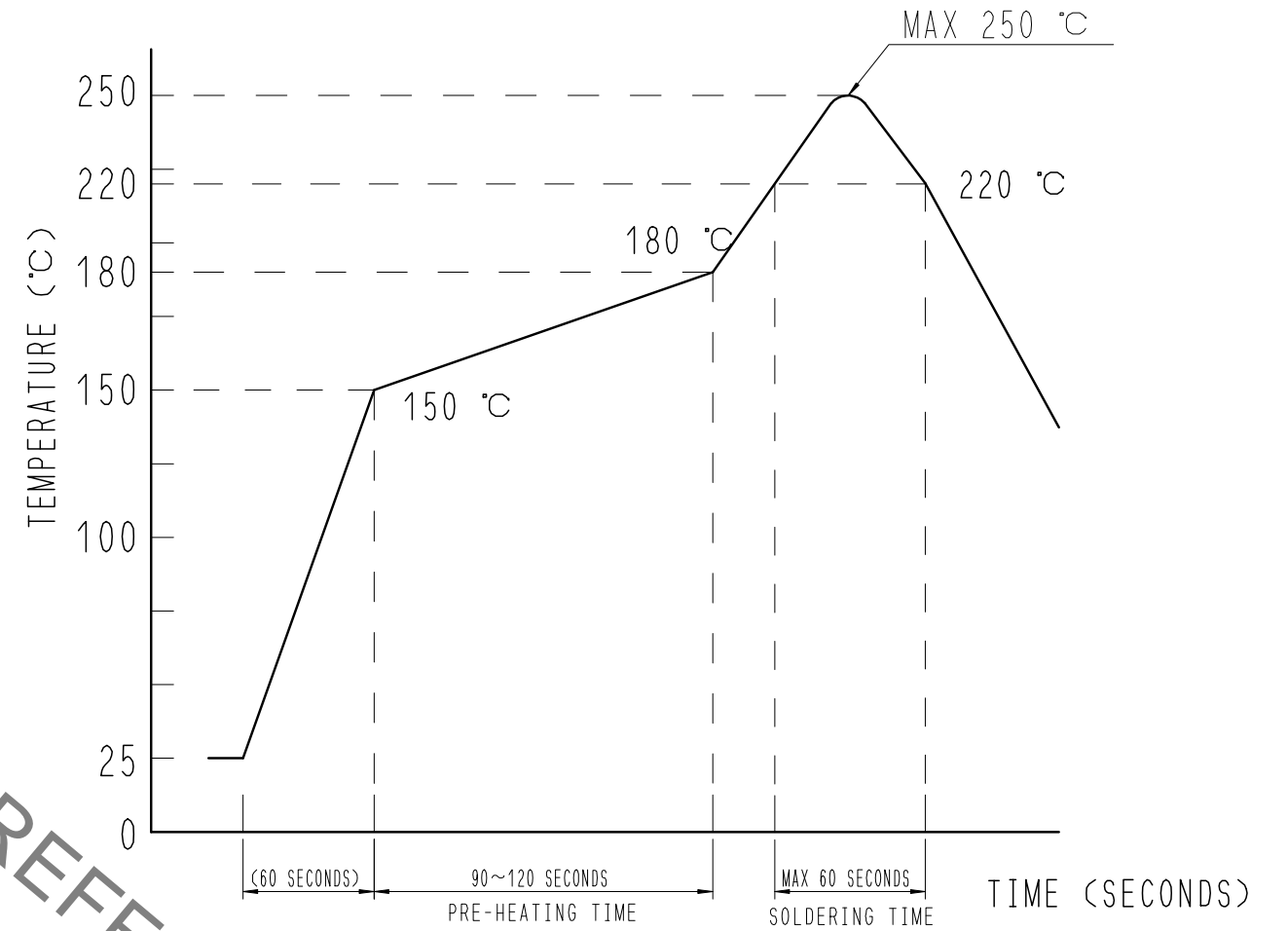

REFLOW METHOD: N2 REFLOW
 NUMBER OF REFLOW CYCLES: 2 CYCLES MAX.
 1) REFLOW TIME
 DURATION ABOVE 220°C, 60 SEC MAX.
 (PEAK TEMPERATURE: 250°C MAX)
 2) PRE-HEAT TIME
 PRE-HEAT TEMPERATURE (MIN): 150°C
 PRE-HEAT TEMPERATURE (MAX): 180°C
 PRE-HEAT TIME: 90-120 SEC.

- 6 THIS TEMPERATURE PROFILE IS PER THE CONDITIONS SHOWN ABOVE. ADDITIONAL FACTORS, SUCH AS SOLDER PASTE TYPE, PCB SIZE AND OTHER MOUNTED COMPONENTS COULD AFFECT THE PROFILE. THEREFORE, A THOROUGH EVALUATION OF MOUNTING CONDITION IS REQUIRED PRIOR TO PRODUCTION. TEMPERATURE IS MEASURED AT CONTACT LEAD.
- 7 PLEASE CONTACT US IN CASE YOU WILL MAKE DIFFERENT SETTINGS FROM OUR RECOMMENDATION.

	DRAWING NO.	EDC3-632176	PART NO.	BM23FR0.6-40DP-0.35V(895)		
	SCALE	10:1	CODE NO	CL 6644-0082-9-895		
UNITS	mm	HIROSE KOREA CO., LTD.		<table border="1"> <tr> <td>2</td> <td>3</td> </tr> </table>	2	3
2	3					

May.1.2023 Copyright 2023 HIROSE ELECTRIC CO., LTD. All Rights Reserved.
In case of consideration for using Automotive equipment / device which demand high reliability, kindly contact our sales window correspondents.

EMBOSED CARRIER TAPE PACKAGING (5:1)

STYLE AND DIMENTION OF REEL (FREE)

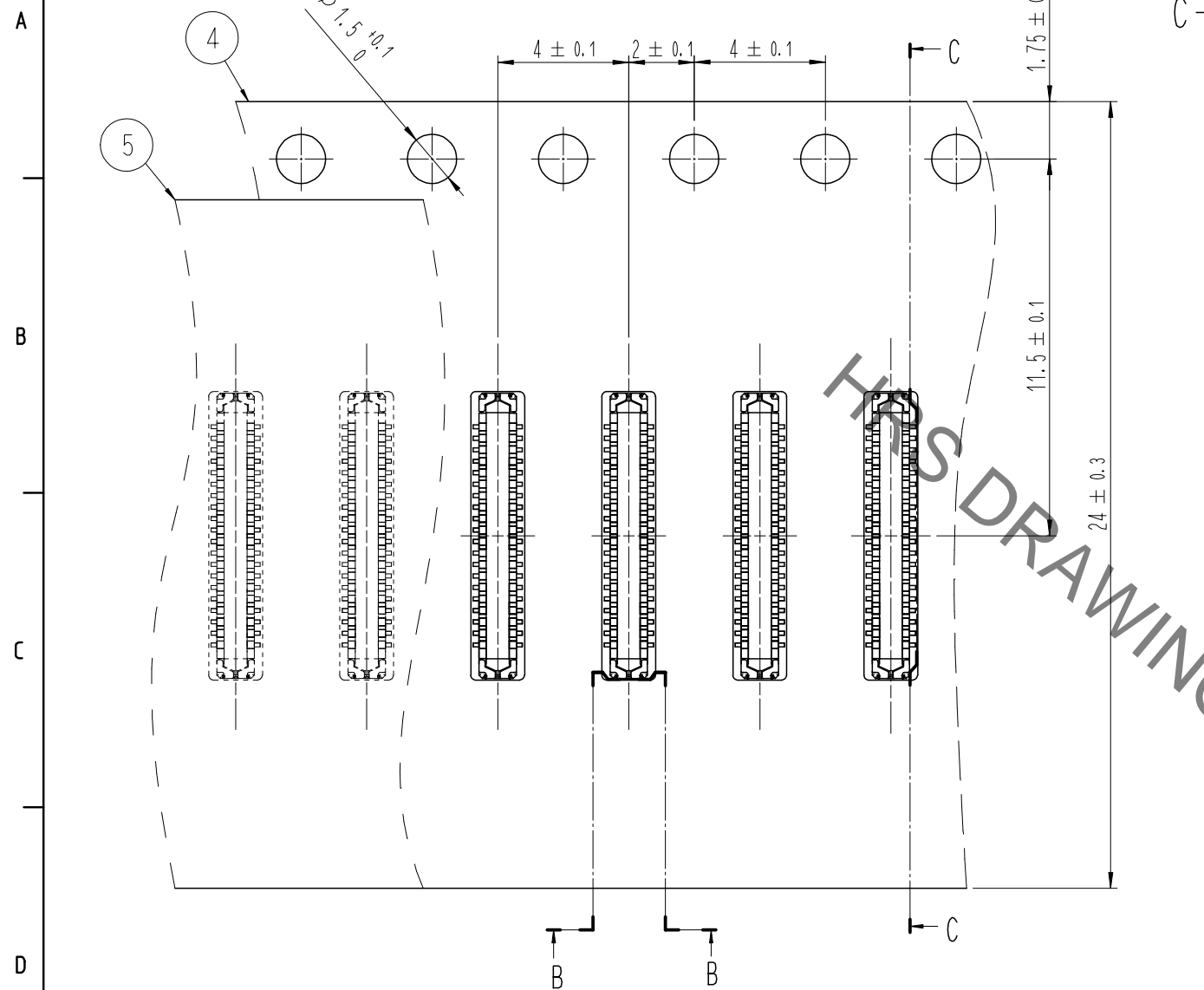

C-C (5:1)

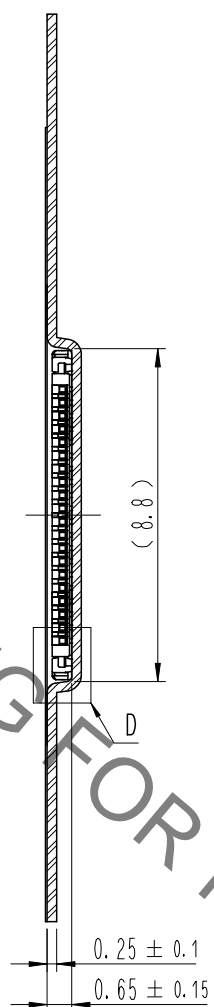

B-B (5:1)

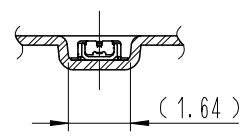

10 TAPING(FREE)

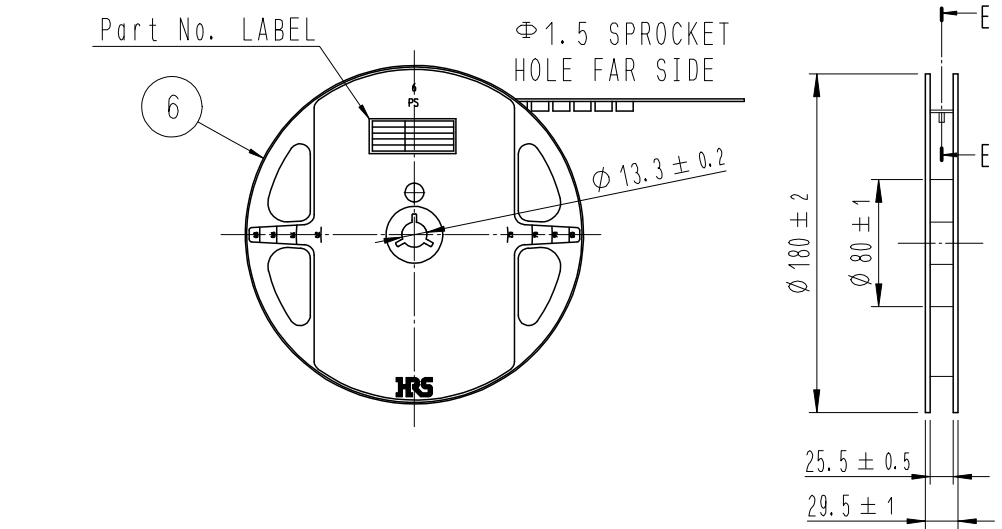
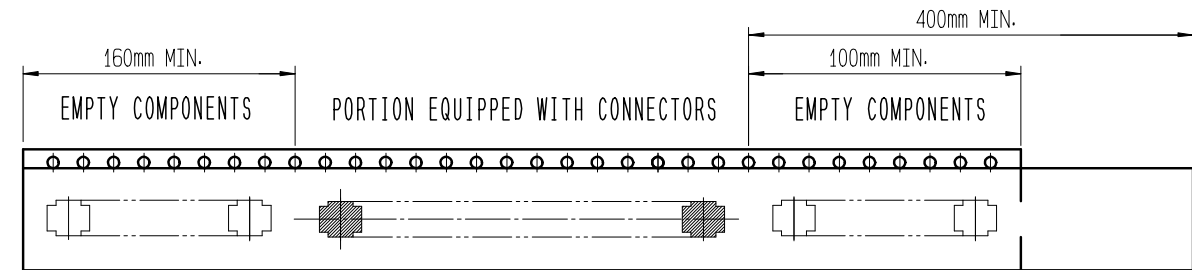

E-E (FREE)

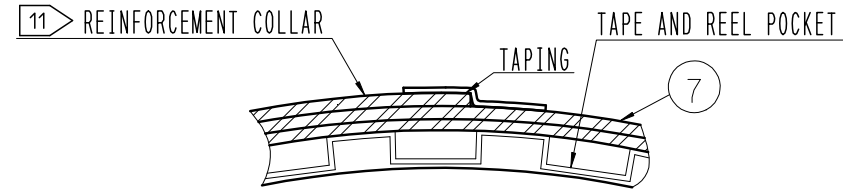

DETAIL OF PART No. LABEL

SUPPLIER	HIROSE ELECTRIC CO., LTD.
QUANTITY	1,000
PART NO.	BM23FR0.6-40DP-0.35V(895)
CODE NO.	CL 6644-0082-9-895
DATE OF MANUFACTURED	生産月日 年 月 日
図番	** ** *
品名	BM23FR0.6-40DP-0.35V(895)
納入数量	1,000個
納入者	HIROSE KOREA

D (10:1)

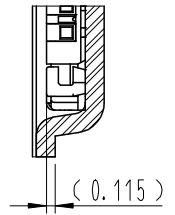

- 8 . PER REEL 1,000 CONNECTORS.
- 9 . THE DIMENSIONS IN PARENTHESES ARE FOR REFERENCE.
- 10 REFER TO JIS C 0806, IEC-60286-3 (PACKAGING OF COMPONENTS FOR AUTOMATIC HANDLING)
- 11 AFTER PACKAGING, ROLL 2 METERS OF THE REINFORCEMENT COLLAR TO OUTER CIRCUMFERENCE OF TAPE AND REEL POCKET. AND TAPE DOWN AT THE END THE COLLAR.

SCALE 10:1	DRAWING NO.	EDC3-632176	PART NO.	BM23FR0.6-40DP-0.35V(895)
	UNITS mm	HIROSE KOREA CO., LTD.		CODE NO CL 6644-0082-9-895