

THIS DRAWING IS UNPUBLISHED. RELEASED FOR PUBLICATION  
 © COPYRIGHT - By - ALL RIGHTS RESERVED.

REVISIONS					
P	LTR	DESCRIPTION	DATE	DWN	APVD
A2		REVISED PER ECO-13-001411	25JAN13	KH	DR
A3		REVISED PER ECO-17-008806	12FEB2018	RS	DR

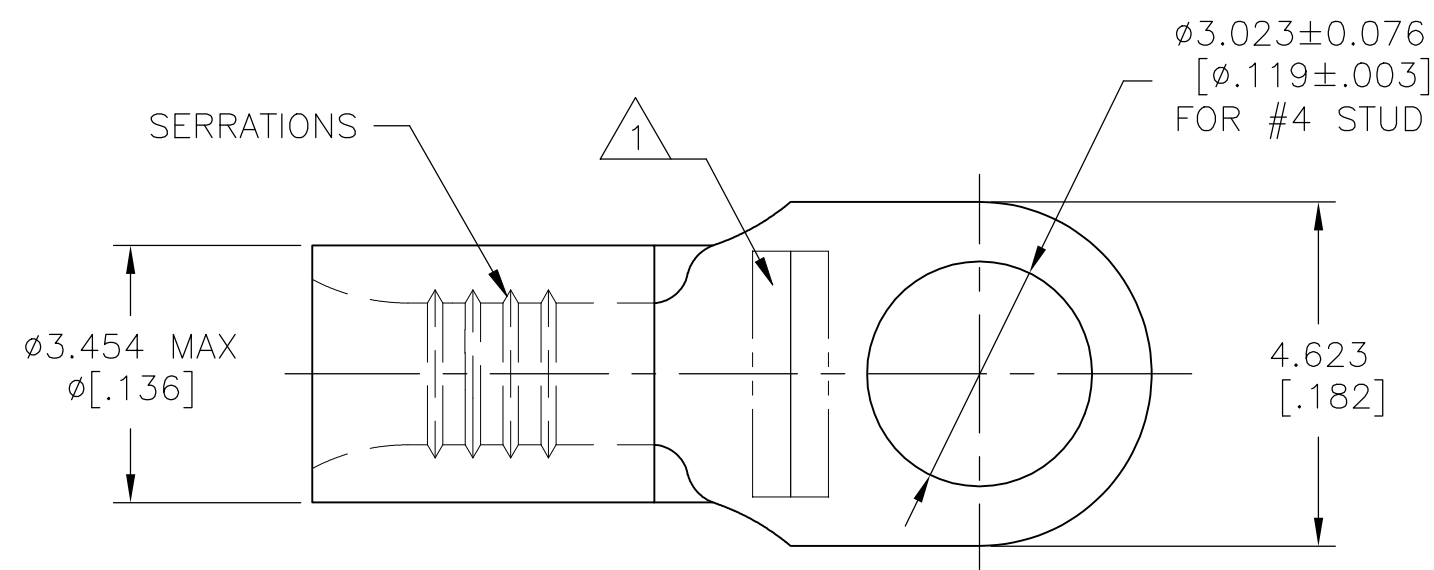

<b>AMP</b> WIRE RANGE	E13288 Listed
22-16 AWG STRANDED	22-16 AWG STRANDED

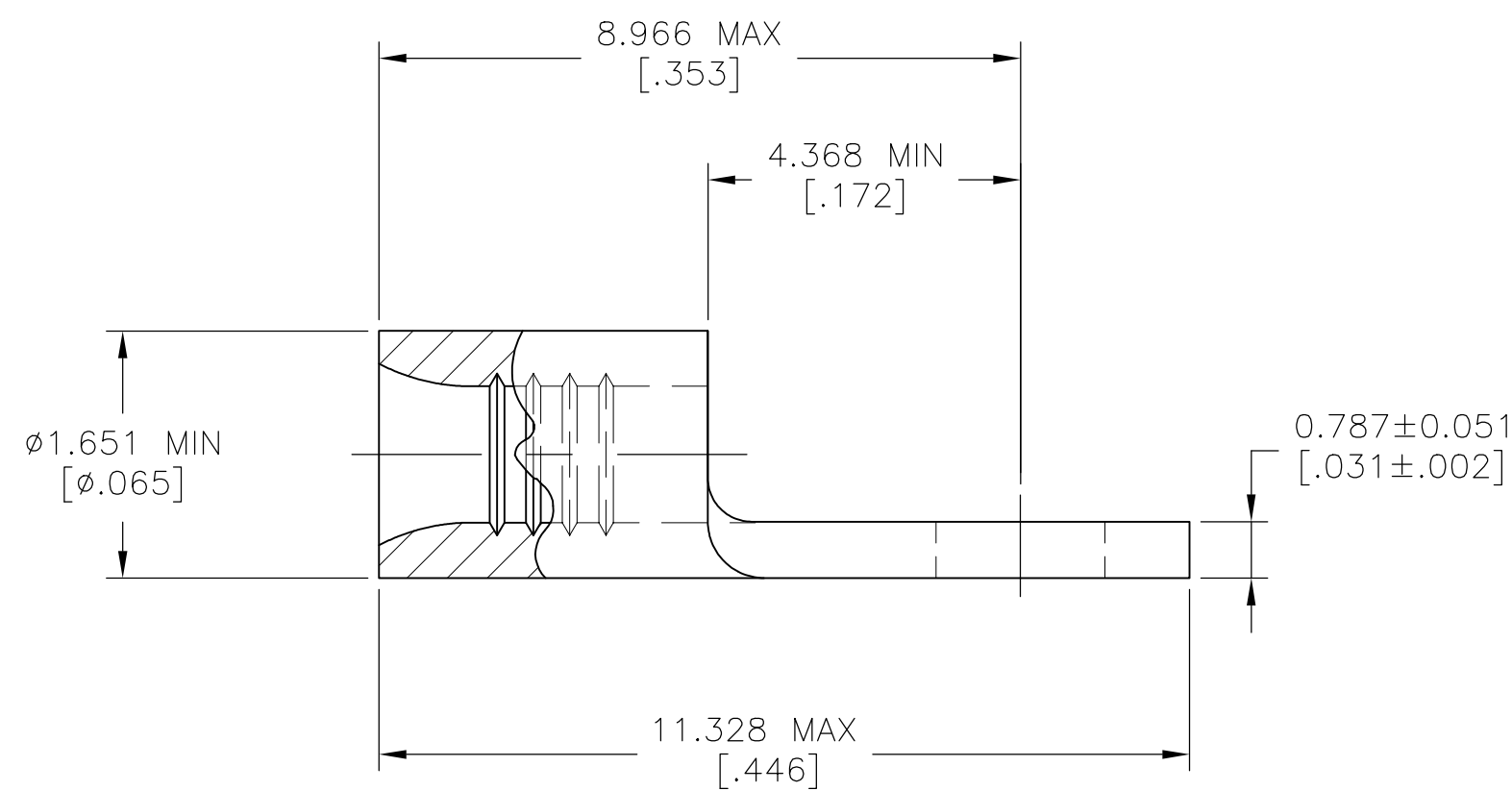

- 1 STAMP AMP 22-18\* APPROX AS SHOWN  
22-16 TERMINALS ARE STAMPED 22-18 IN  
ACCORDANCE WITH MILITARY SPECIFICATION  
SAE AS7928, COMMERCIAL WIRE RANGE IS 22-16
- 2 NOTE DELETED
- 3 NOTE DELETED
- 4 FINISH: TIN PLATE 0.00254 [0.000100] MIN EXT  
THK PER ASTM B545

**AMP INCORPORATED  
CUSTOMER SERVICE SYSTEMS**

MAX RECOMMENDED OPERATING  
TEMPERATURE:  
170°C[338°F] MAX

FOR ADDITIONAL  
PRODUCT INFORMATION OR  
COPIES OF DRAWINGS  
AND TECHNICAL DOCUMENTS

PRODUCT INFORMATION CENTER  
1-800-522-6752

VOLTAGE RATING:  
NOT APPLICABLE

FOR APPLICATION  
TOOLING INFORMATION

TOOLING ASSISTANCE CENTER  
1-800-722-1111

WIRE CROSS SECTIONAL AREA RANGE:  
0.26-1.65mm<sup>2</sup> [509-3,260] CIR MILS  
STRANDED

FOR ORDER ENTRY

1-800-526-5142

THIS DRAWING IS A CONTROLLED DOCUMENT FOR  
AMP INCORPORATED. IT IS SUBJECT TO CHANGE  
AND THE CONTROLLING ENGINEERING ORGANIZATION  
SHOULD BE CONTACTED FOR THE LATEST REVISION.

	1000	LOOSE PIECE	36189
FINISH	QUANTITY	PACKAGE TYPE	PART NUMBER
THIS DRAWING IS A CONTROLLED DOCUMENT.		DWN TA BRINKMAN 2-2-93	
DIMENSIONS: mm [INCHES]		CHK DA PATTERSON 2-2-93	
TOLERANCES UNLESS OTHERWISE SPECIFIED:		APVD DE MILLER 2-2-93	
0 PLC ± -		NAME	
1 PLC ± -		TE Connectivity Ltd.	
2 PLC ± -		PRODUCT SPEC	
3 PLC ± 0.127[.005]		UL 486 A-B	
4 PLC ± -		APPLICATION SPEC	
ANGLES ± -		SIZE CAGE CODE DRAWING NO RESTRICTED TO	
MATERIAL	FINISH	WEIGHT	SCALE SHEET REV
COPPER PER ASTM B-152 ANNEALED	SEE TABLE		A2 00779 C-36189 10:1 1 of 1 A3
CUSTOMER DRAWING			