

BASE CAGE DETAILS

2031433245 SHWON

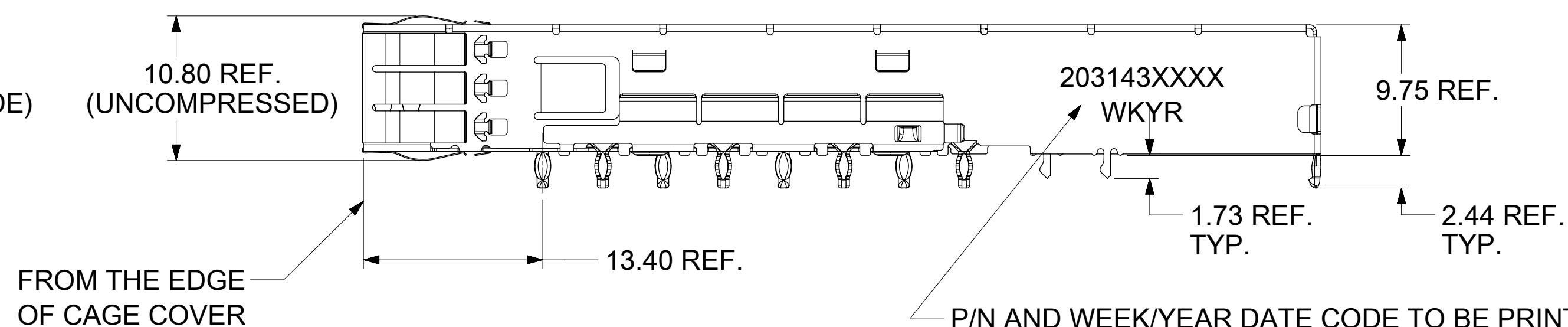
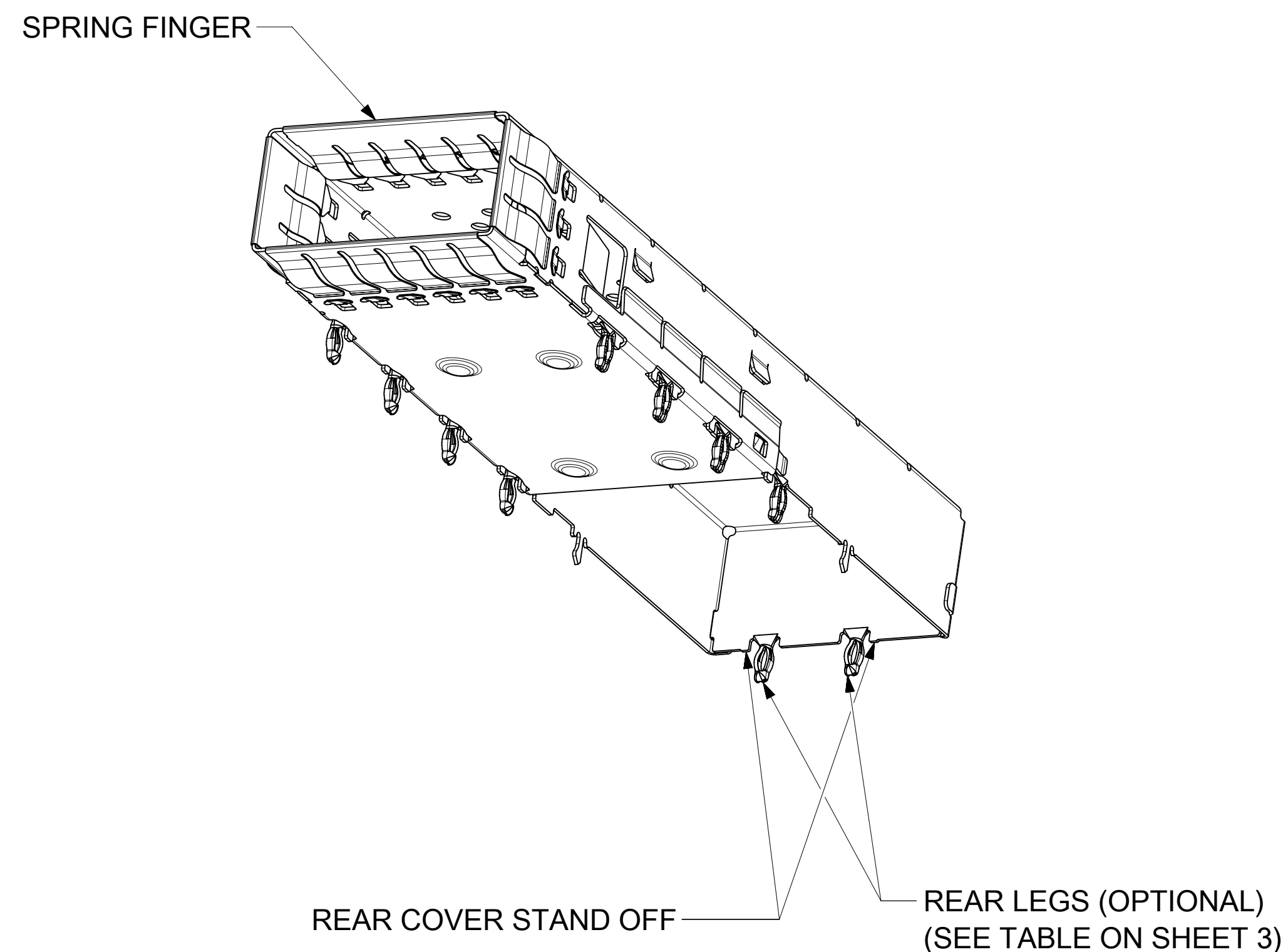
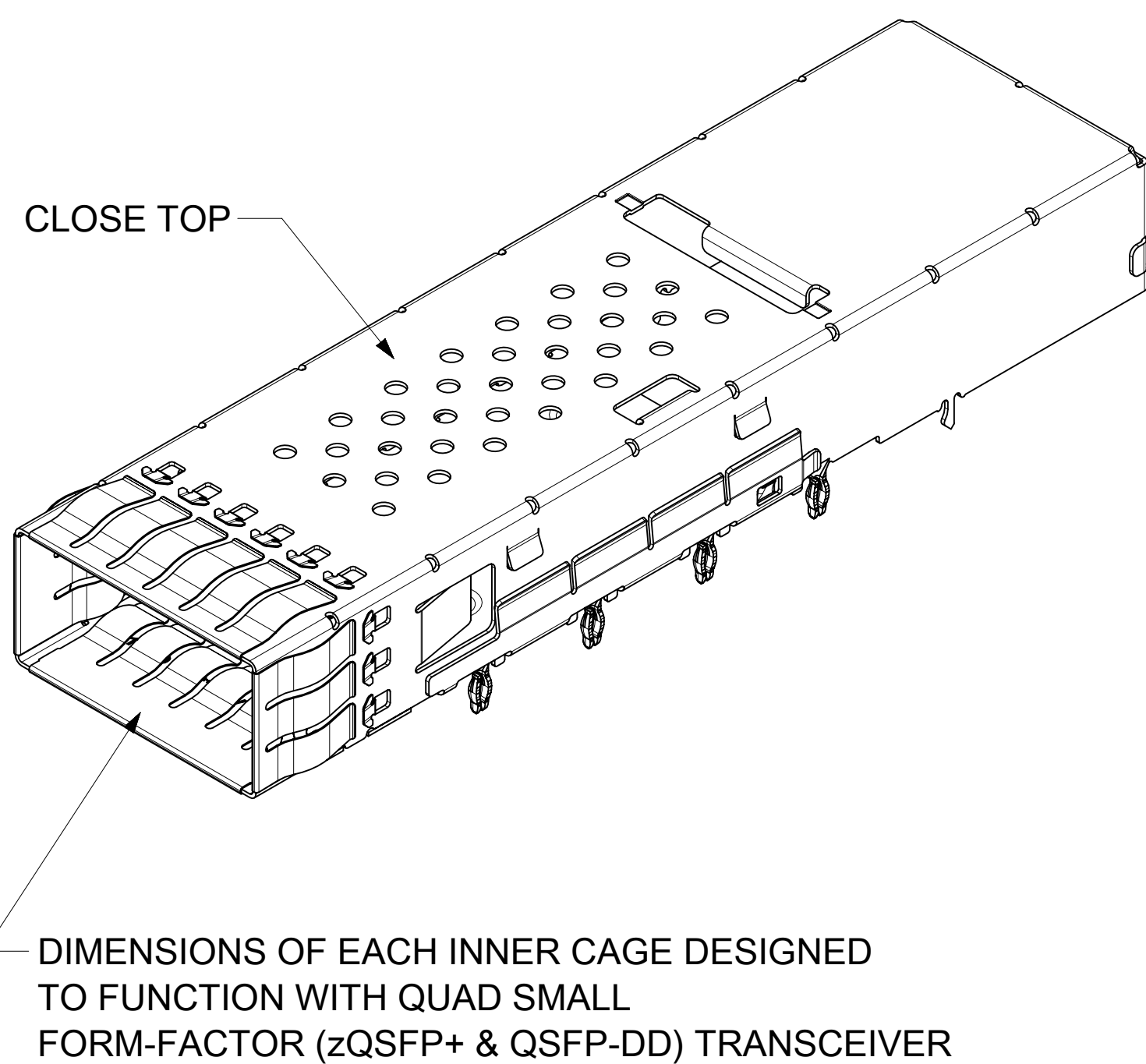
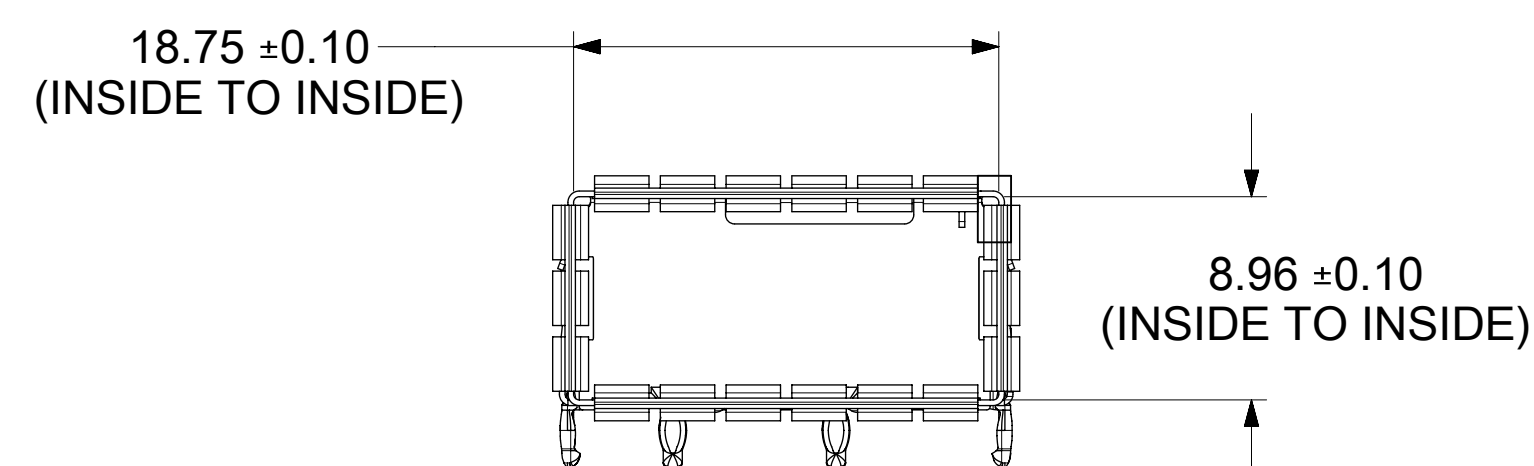
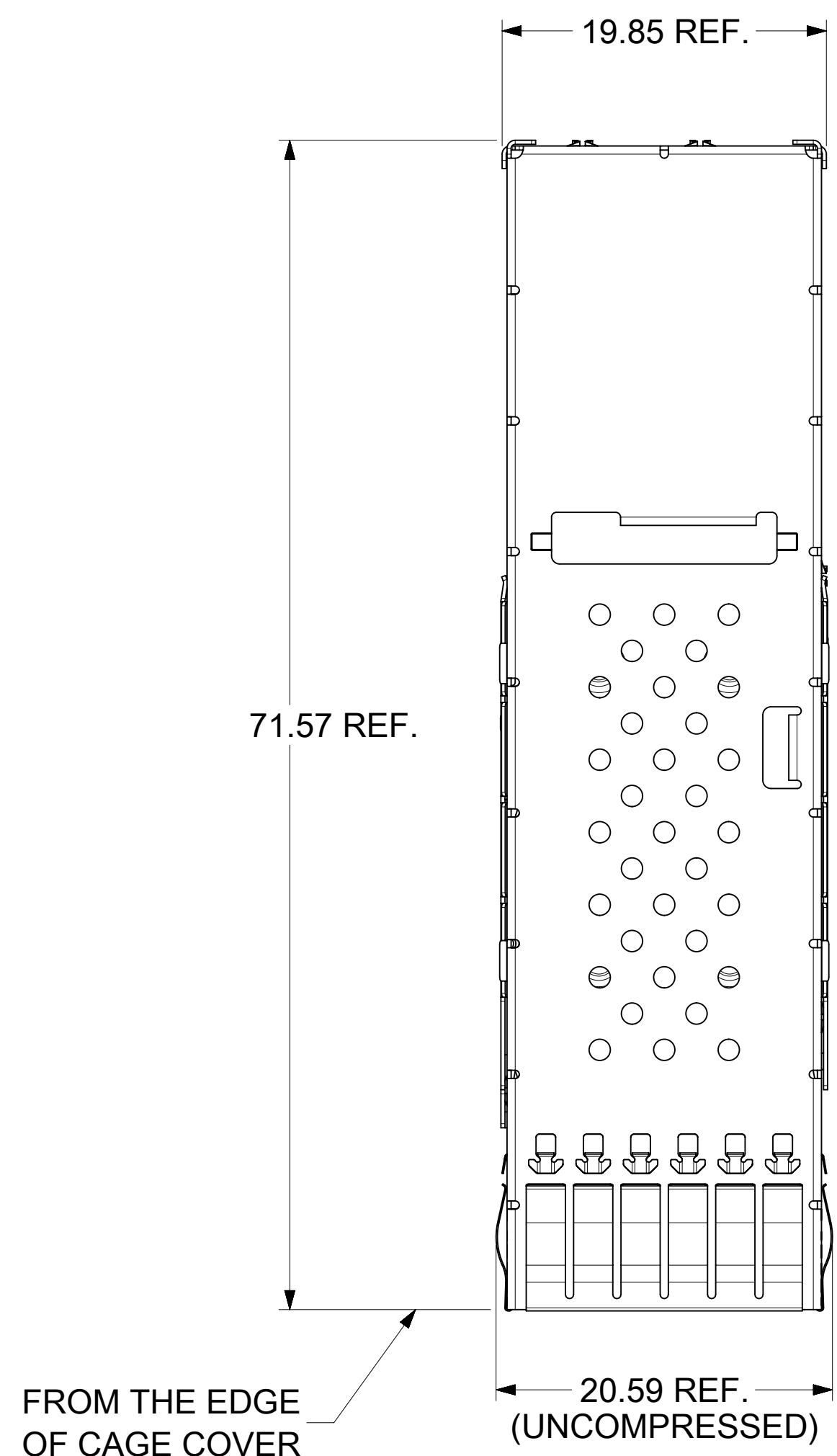

P/N AND WEEK/YEAR DATE CODE TO BE PRINTED ON SIDE OF COMPLETED CAGE ASSEMBLY APPROXIMATELY AS SHOWN. SEE TABLE BELOW FOR DATE CODE INFORMATION.

WEEK/YEAR DATE CODE TABLE

WK	WEEK OF THE YEAR 01 THRU 52 OR 53 (EXAMPLE: 01= FIRST WEEK OF YEAR, 52 OR 53 = LAST WEEK OF YEAR)
YR	17, 18, 19 ETC.. (EXAMPLE: YEAR 2017= 17)

NOTES:

- MATERIAL: CAGE: STAINLESS STEEL
SPRING FINGERS: STAINLESS STEEL
HEAT SINKS: ALUMINUM(BLACK ANODIZATION)
HEAT SINK CLIP: STAINLESS STEEL
- DRAWING APPLIES TO ALL P/N'S SHOWN ON PAGE 3 AND SHEET 4
- DURING FINAL INSPECTION, CAGE LEG LOCATIONS AND STRAIGHTNESS MUST BE CHECKED USING APPROPRIATE GO - NO GO GAGE
- DURING FINAL INSPECTION, CAGE MUST BE INSPECTED TO MAKE SURE LEG CONFIGURATIONS AND PART NUMBERS ARE CORRECT, REFER TO SHEETS 2 AND 3.
- PARTS TO BE INSPECTED PER MOLEX COSMETIC SPEC WI-HP-7-2774 (CLASS B UNLESS OTHERWISE SPECIFIED)
- PRESS-FIT LEGS 2.44mm LONG -
1.57mm MINIMUM PCB THICKNESS FOR SINGLE SIDED USE.
2.70mm MINIMUM PCB THICKNESS FOR BELLY TO BELLY USE.
- NO RoHS EXEMPTIONS

THIS DRAWING CONTAINS INFORMATION THAT IS PROPRIETARY TO MOLEX ELECTRONIC TECHNOLOGIES, LLC AND SHOULD NOT BE USED WITHOUT WRITTEN PERMISSION									
DIMENSION UNITS	SCALE	CURRENT REV DESC: SEE REVISION TABLE							
mm	3:1	<p>QSFP-DD 1X1 CAGE ASSY SF WITH FIN H/S OPTIONS</p> <p>PRODUCT CUSTOMER DRAWING</p>							
GENERAL TOLERANCES (UNLESS SPECIFIED)									
ANGULAR TOL	± 2.0°								
4 PLACES	±								
3 PLACES	±								
2 PLACES	± 0.13								
1 PLACE	± 0.25	EC NO: 705875	2022/08/04	<p>DRWN: MCHEN104</p> <p>CHK'D: THSU02</p> <p>APPR: SCHIEN</p>					
0 PLACES	±	DRWN: SCHIEN	2019/06/10						
DRAFT WHERE APPLICABLE MUST REMAIN WITHIN DIMENSIONS		APPR: JCHIANG	2019/08/16						
THIRD ANGLE PROJECTION	DRAWING	SERIES	MATERIAL NUMBER	CUSTOMER	DOCUMENT NUMBER	DOC TYPE	DOC PART	REVISION	
THIRD ANGLE PROJECTION	D-SIZE	203143	SEE P/N TABLE	GENERAL MARKET	2031433201	PSD	ASY	A5	
									SHEET NUMBER
									1 OF 7

CAGE ASSEMBLY OPTIONS

2031433349 SHOWN

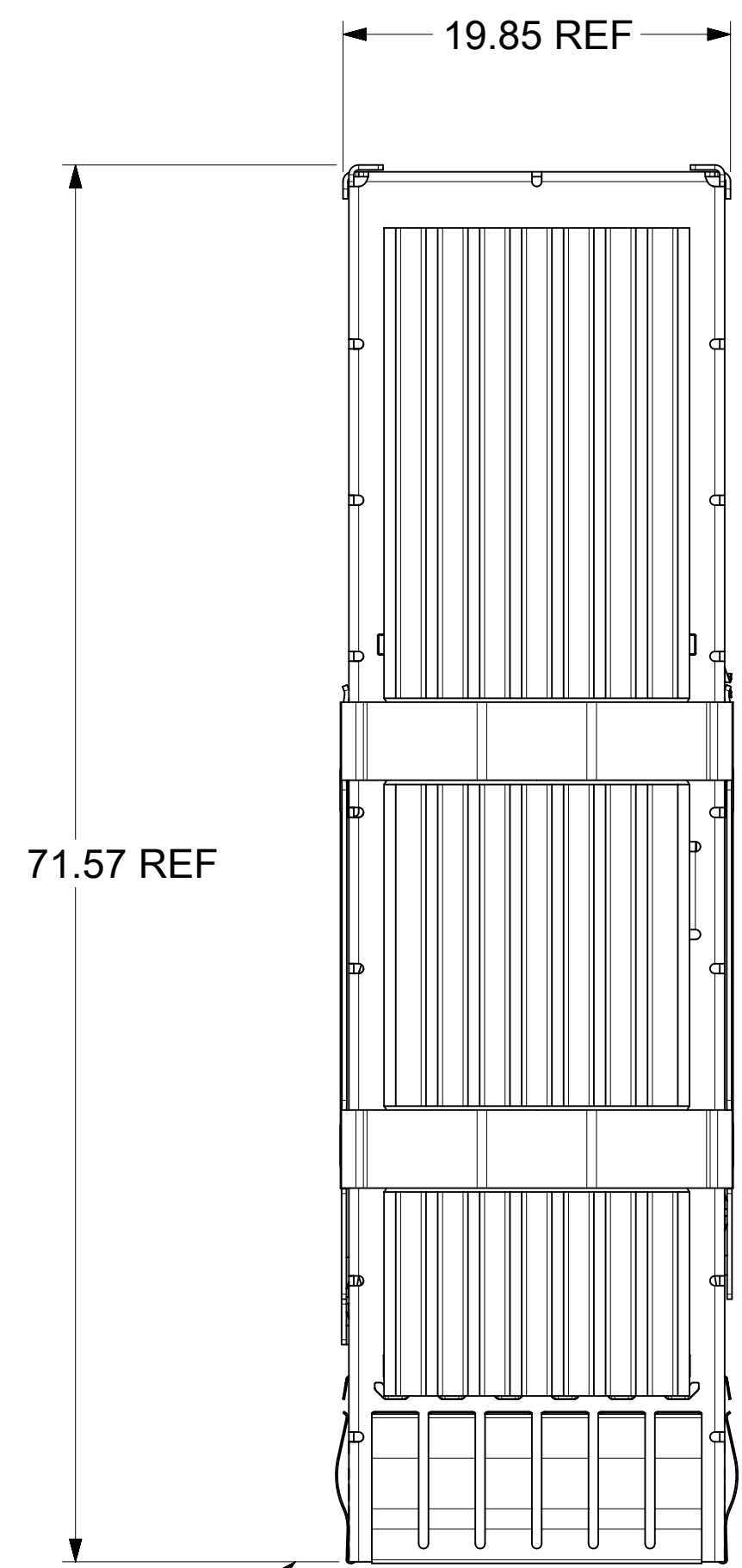

FROM THE EDGE OF CAGE COVER

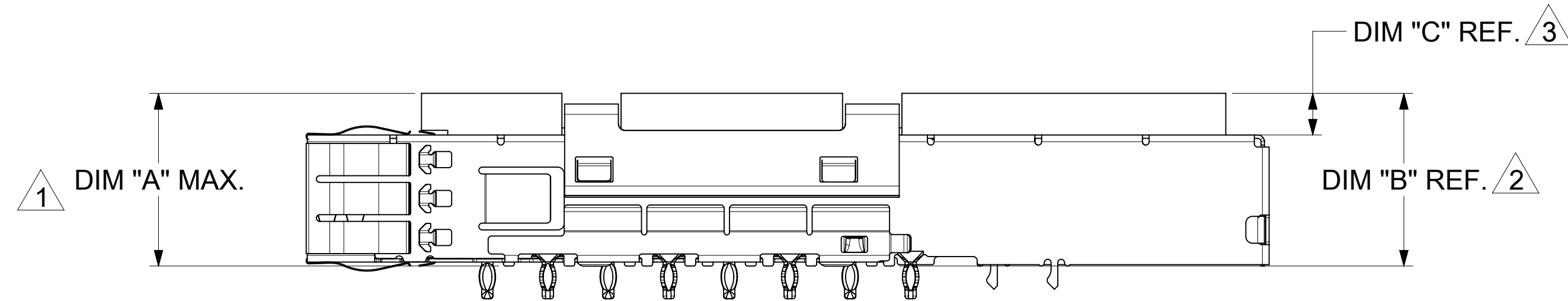
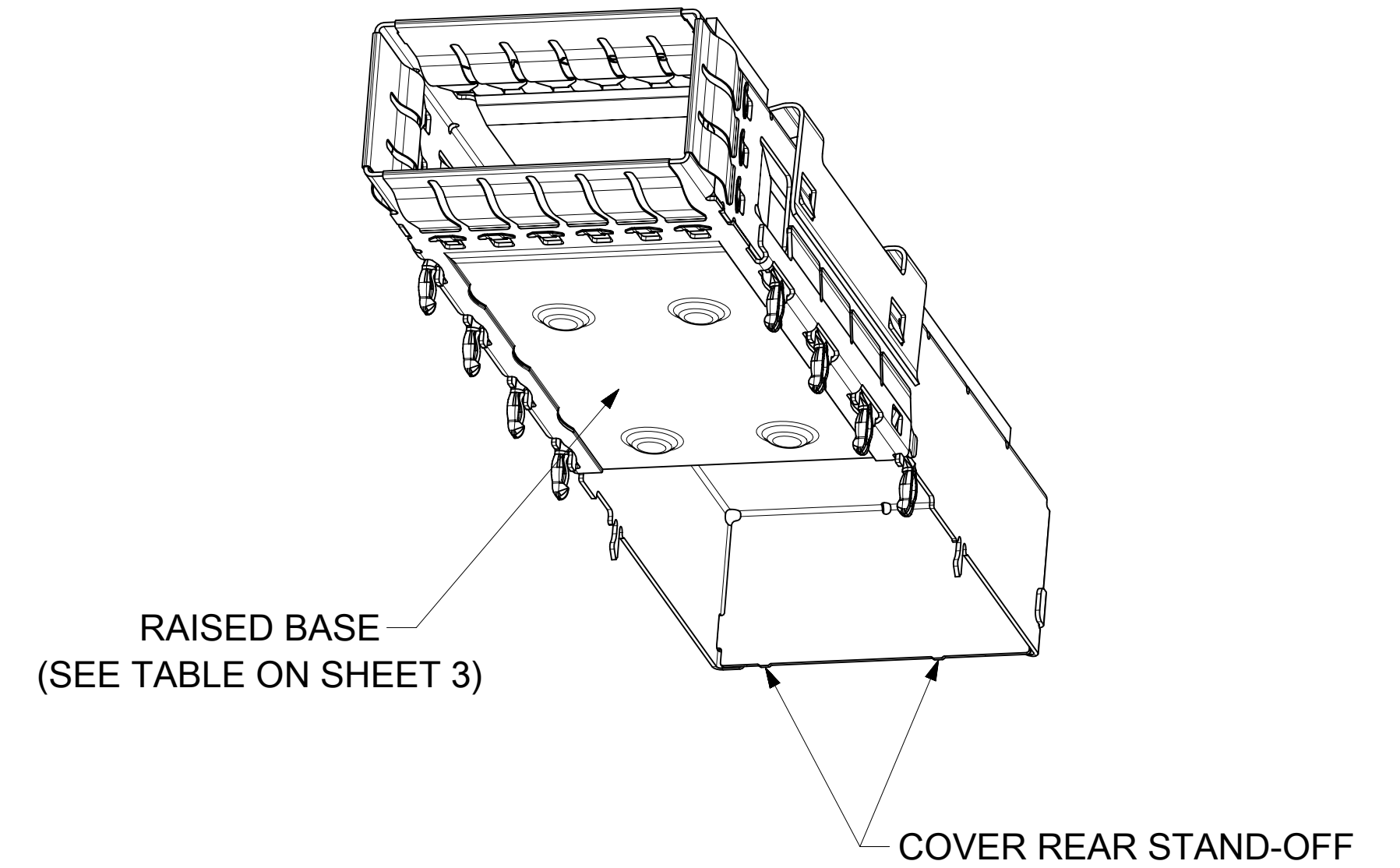
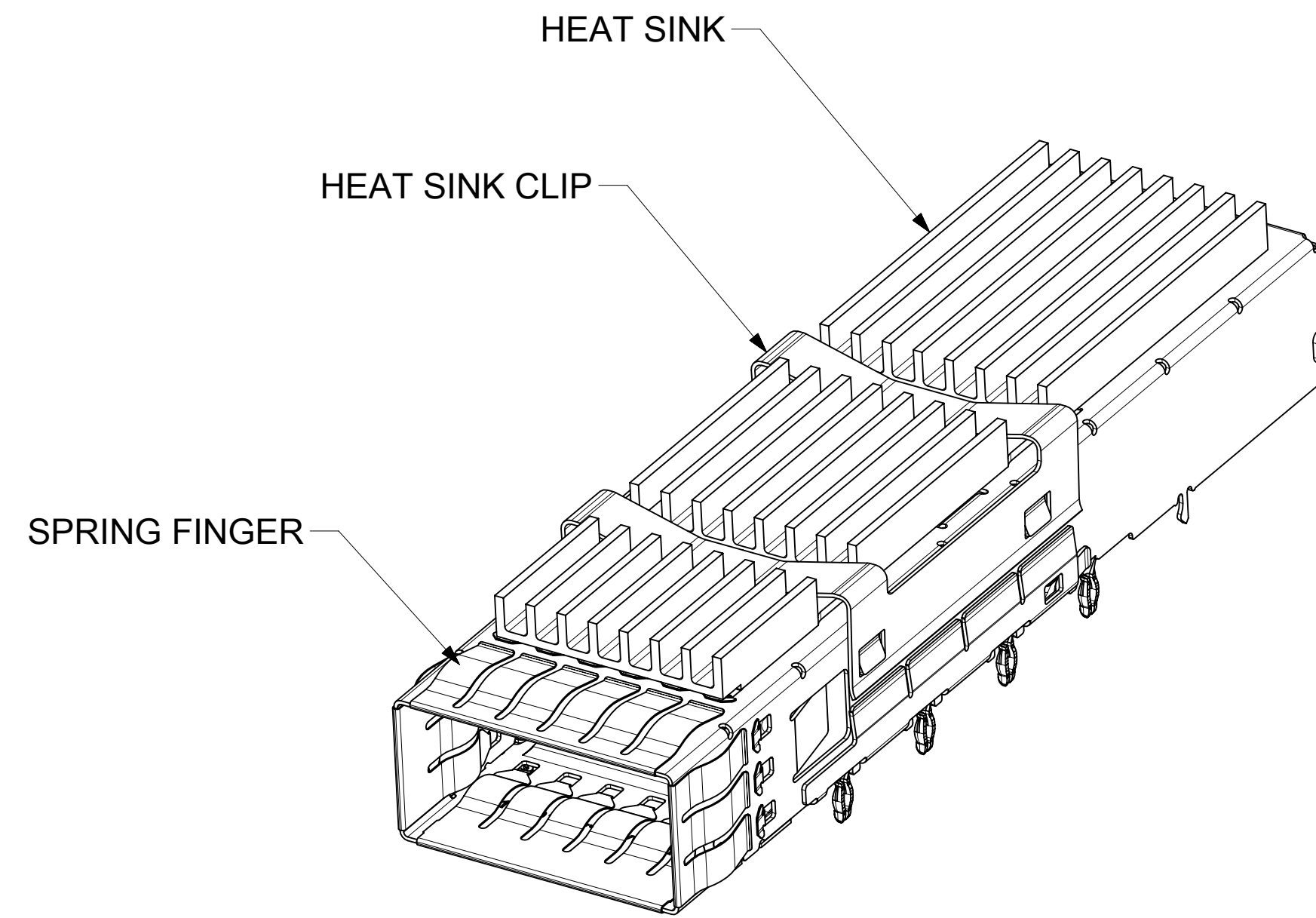
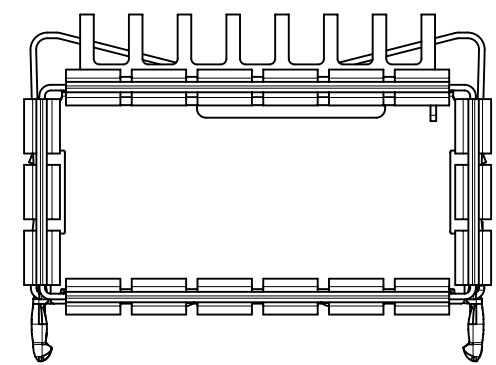

HEAT SINK HEIGHT OPTIONS

OVERALL HEAT SINK HEIGHT	DIM "A"
PCI	13.7
SAN	16.0
NET	23.0

OVERALL HEAT SINK HEIGHT	DIM "B"
PCI	12.85
SAN	15.15
NET	22.15

HEAT SINK HEIGHT	DIM "C"
PCI	3.10
SAN	5.40
NET	12.40

THIS DRAWING CONTAINS INFORMATION THAT IS PROPRIETARY TO MOLEX ELECTRONIC TECHNOLOGIES, LLC AND SHOULD NOT BE USED WITHOUT WRITTEN PERMISSION

DIMENSION UNITS: mm SCALE: 3:1

GENERAL TOLERANCES (UNLESS SPECIFIED)

ANGULAR TOL	± 2.0°
4 PLACES	±
3 PLACES	±
2 PLACES	± 0.13
1 PLACE	± 0.25
0 PLACES	±

CURRENT REV DESC: SEE REVISION TABLE

EC NO: 705875
 DRWN: MCHEN104 2022/08/04
 CHK'D: THSU02 2022/08/05
 APPR: SCHIEN 2022/08/08

INITIAL REVISION:
 DRWN: SCHIEN 2019/06/10
 APPR: JCHIANG 2019/08/16

molex

QSFP-DD 1X1 CAGE ASSY
 SF WITH FIN H/S OPTIONS

PRODUCT CUSTOMER DRAWING

DOCUMENT NUMBER	DOC TYPE	DOC PART	REVISION
2031433201	PSD	ASY	A5

DRAFT WHERE APPLICABLE MUST REMAIN WITHIN DIMENSIONS	THIRD ANGLE PROJECTION	DRAWING	SERIES	MATERIAL NUMBER	CUSTOMER	SHEET NUMBER
		D-SIZE	203143	SEE P/N TABLE	GENERAL MARKET	2 OF 7

1 HEIGHT OF HEAT SINK WITH MODULE INSERTED. DIMENSION MAY BE LESS DUE TO MODULE AND HEAT SINK VARIATIONS

2 HEIGHT OF HEAT SINK WITHOUT MODULE INSERTED.

3 HEIGHT OF HEAT SINK

PART NUMBER SELECTION

CLOSE TOP

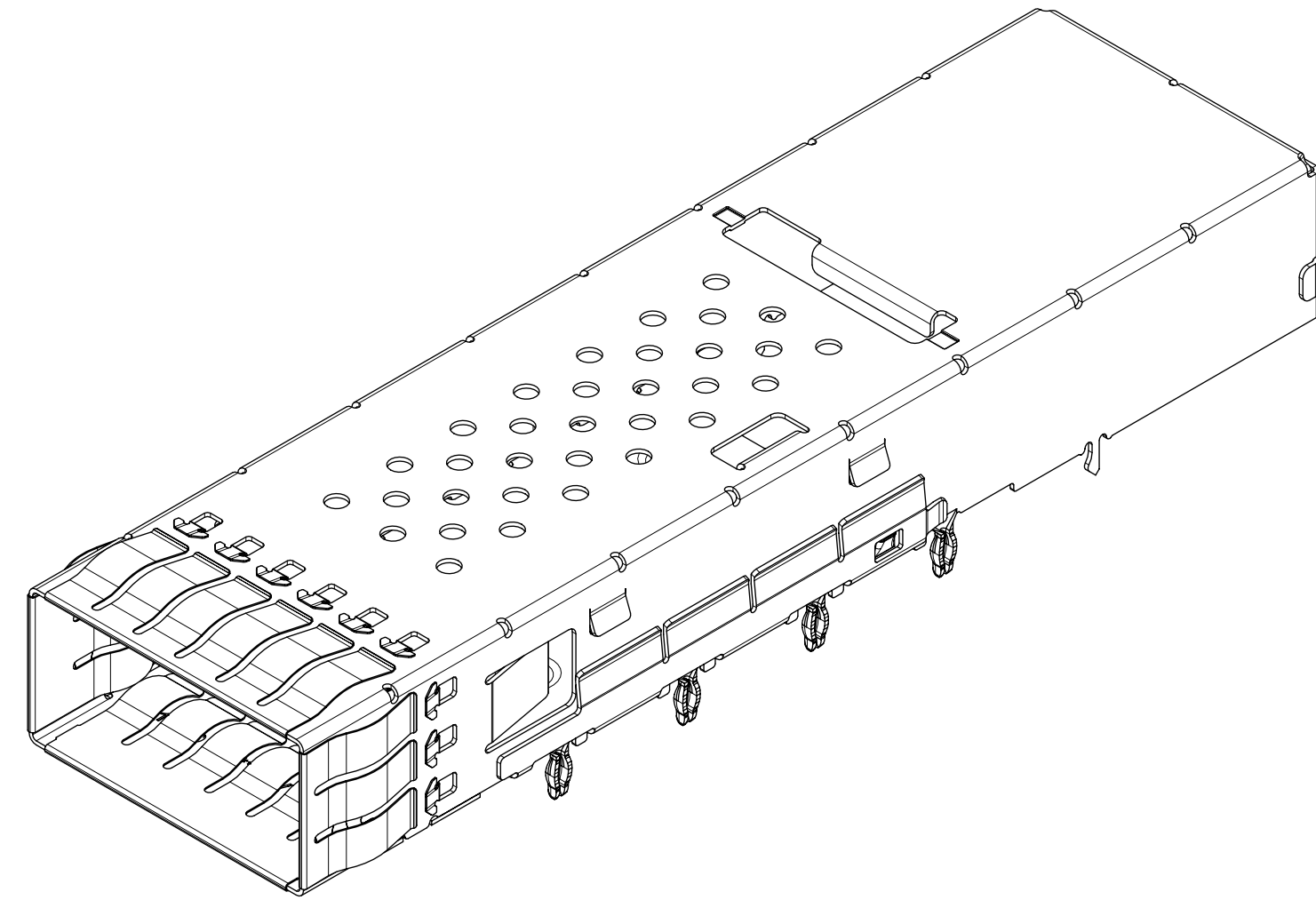

OPEN TOP

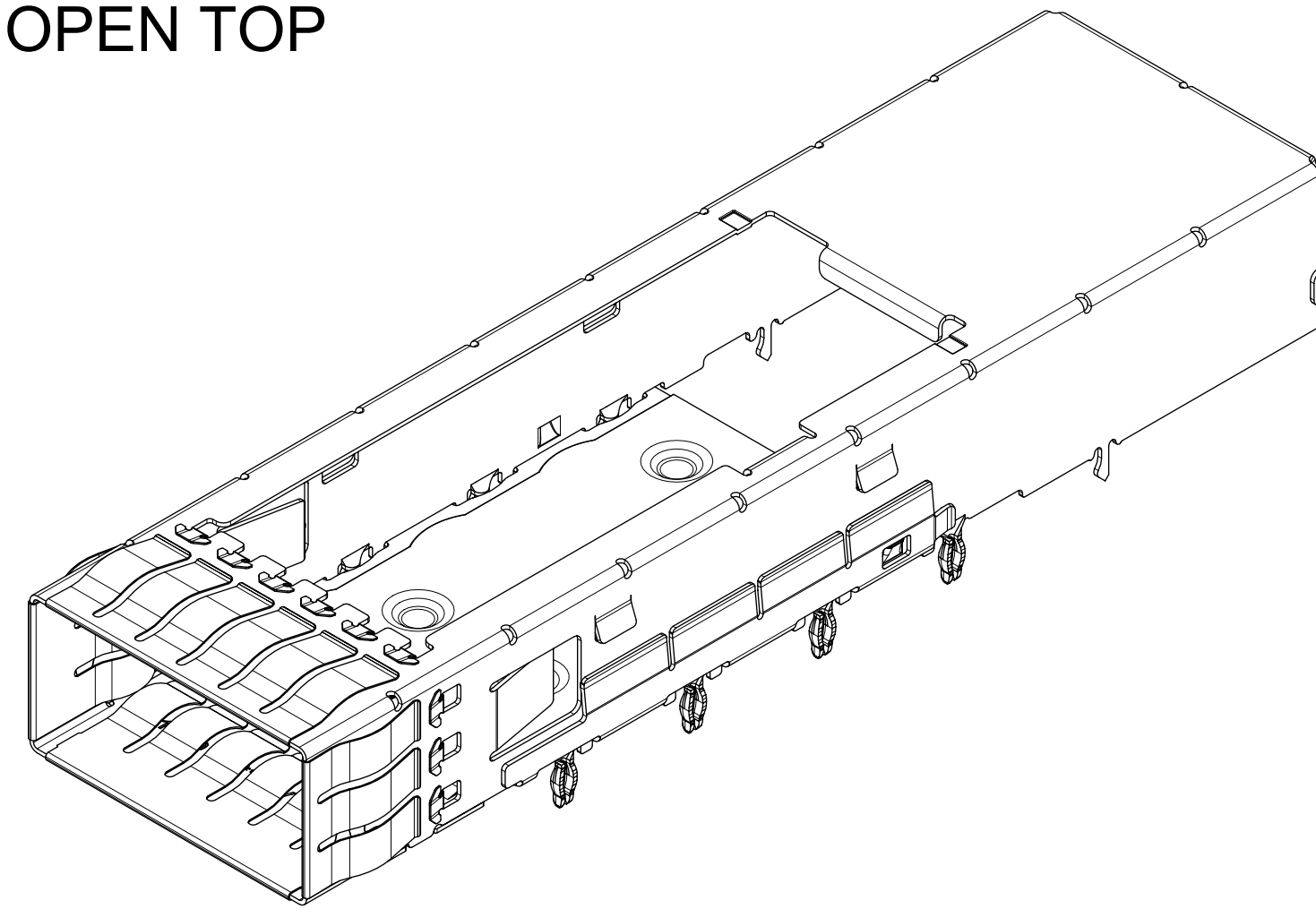

WITH HEAT SINK

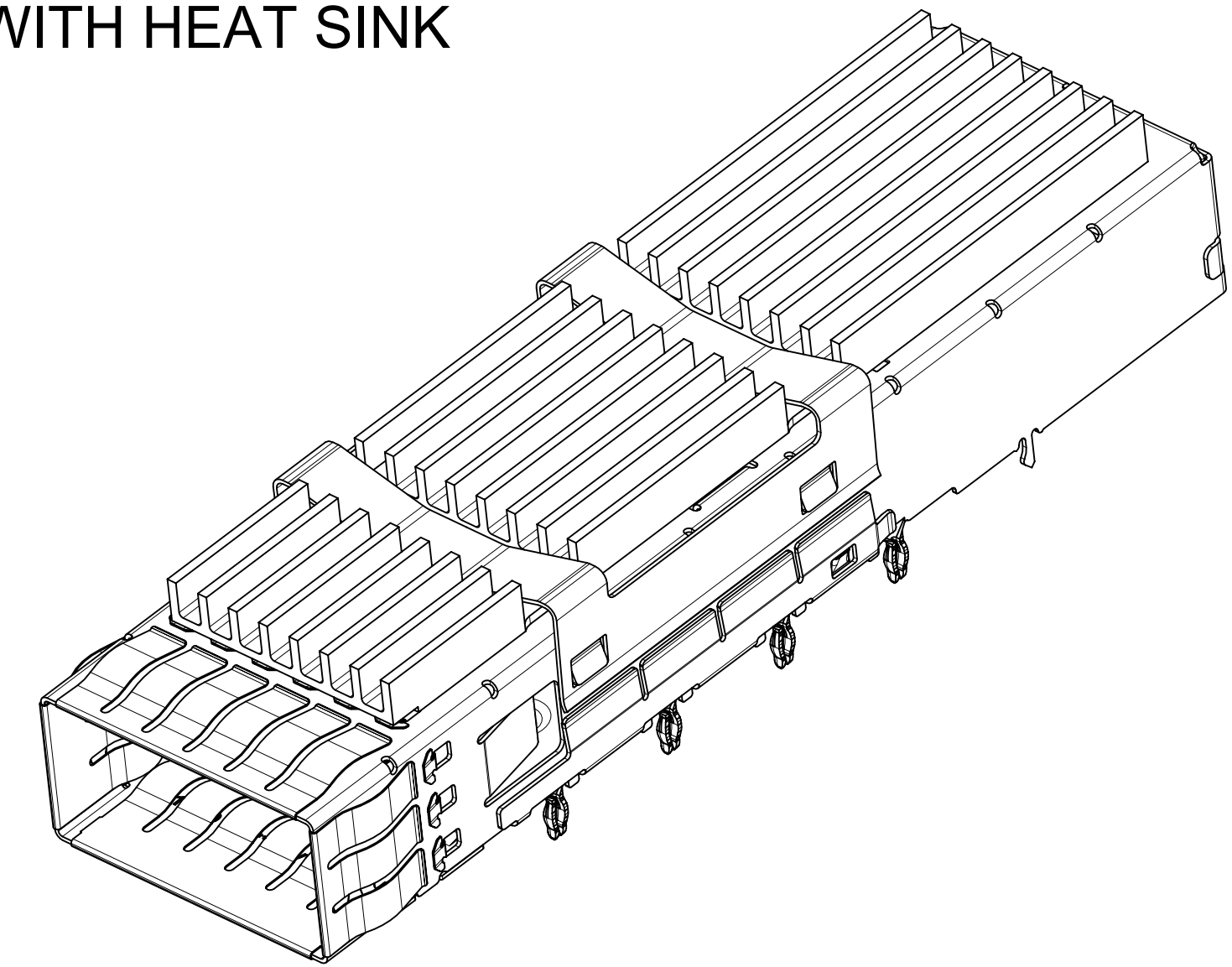

MOLEX P/N	# OF REAR LEGS PER PORT	RAISED BASE	W/ EMI ABSORB
2031433243	0	NO	NO
2031433244	1	NO	NO
2031433245	2	NO	NO

OBSOLETE

MOLEX P/N	# OF REAR LEGS PER PORT	RAISED BASE	W/ EMI ABSORB
2031433254	0	YES	NO
2031433255	1	YES	NO
2031433256	2	YES	NO

MOLEX P/N	HEAT SINK	# OF REAR LEGS PER PORT	RAISED BASE	W/ EMI ABSORB
2031433349	PCI	0	YES	NO
2031433350	SAN	0	YES	NO
2031433351	NET	0	YES	NO
2031433352	PCI	1	YES	NO
2031433353	SAN	1	YES	NO
2031433354	NET	1	YES	NO
2031433355	PCI	2	YES	NO
2031433356	SAN	2	YES	NO
2031433357	NET	2	YES	NO

REAR LEG OPTIONS

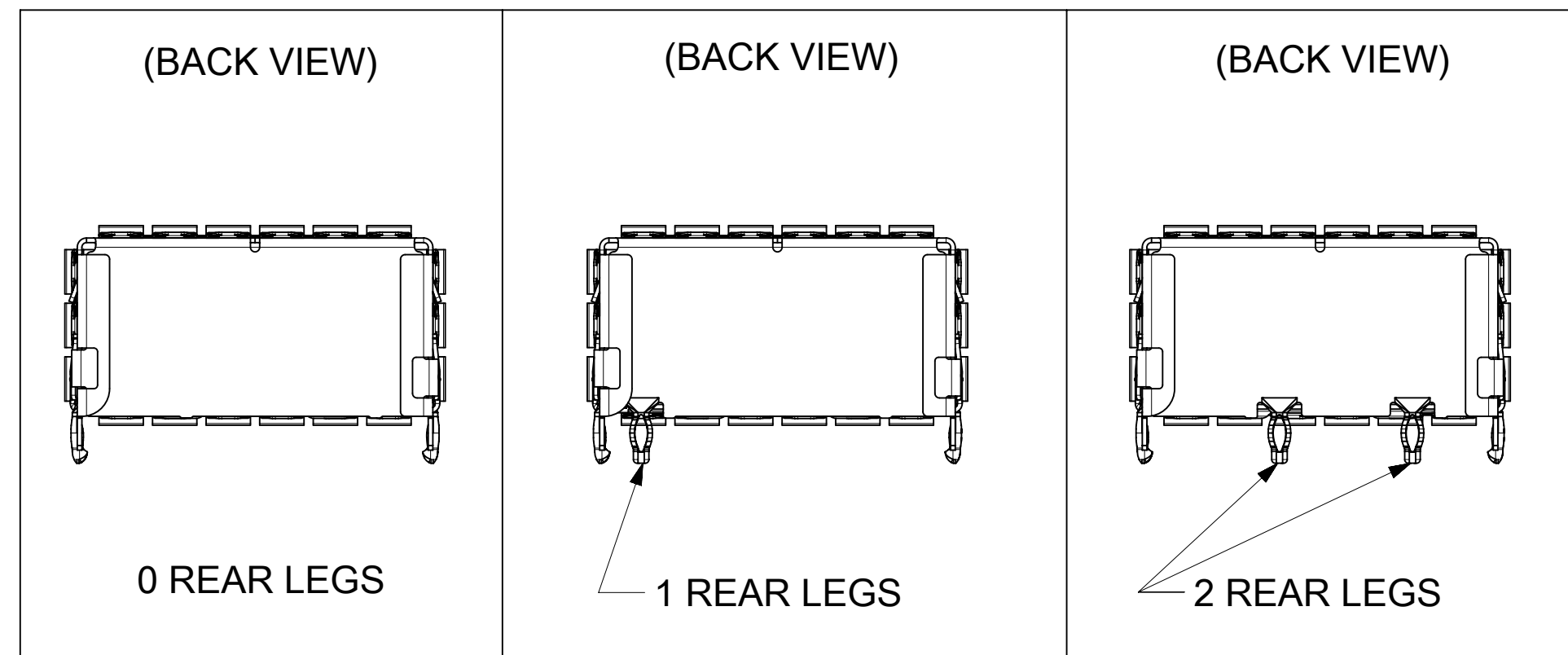

THIS DRAWING CONTAINS INFORMATION THAT IS PROPRIETARY TO MOLEX ELECTRONIC TECHNOLOGIES, LLC AND SHOULD NOT BE USED WITHOUT WRITTEN PERMISSION			
DIMENSION UNITS	SCALE	CURRENT REV DESC: SEE REVISION TABLE	
mm	3:1		
GENERAL TOLERANCES (UNLESS SPECIFIED)			
ANGULAR TOL ± 2.0°			
4 PLACES ±	EC NO: 705875 DRWN: MCHEN104 2022/08/04 CHK'D: THSU02 2022/08/05 APPR: SCHIEN 2022/08/08 INITIAL REVISION: DRWN: SCHIEN 2019/06/10 APPR: JCHIANG 2019/08/16		
3 PLACES ±			
2 PLACES ± 0.13			
1 PLACE ± 0.25			
0 PLACES ±			
DRAFT WHERE APPLICABLE MUST REMAIN WITHIN DIMENSIONS		THIRD ANGLE PROJECTION	DRAWING
		D-SIZE	SERIES
		203143	MATERIAL NUMBER
		SEE P/N TABLE	CUSTOMER
		GENERAL MARKET	SHEET NUMBER
		3 OF 7	3 OF 7

PCB LAYOUT FOR SINGLE SIDED MOUNTING

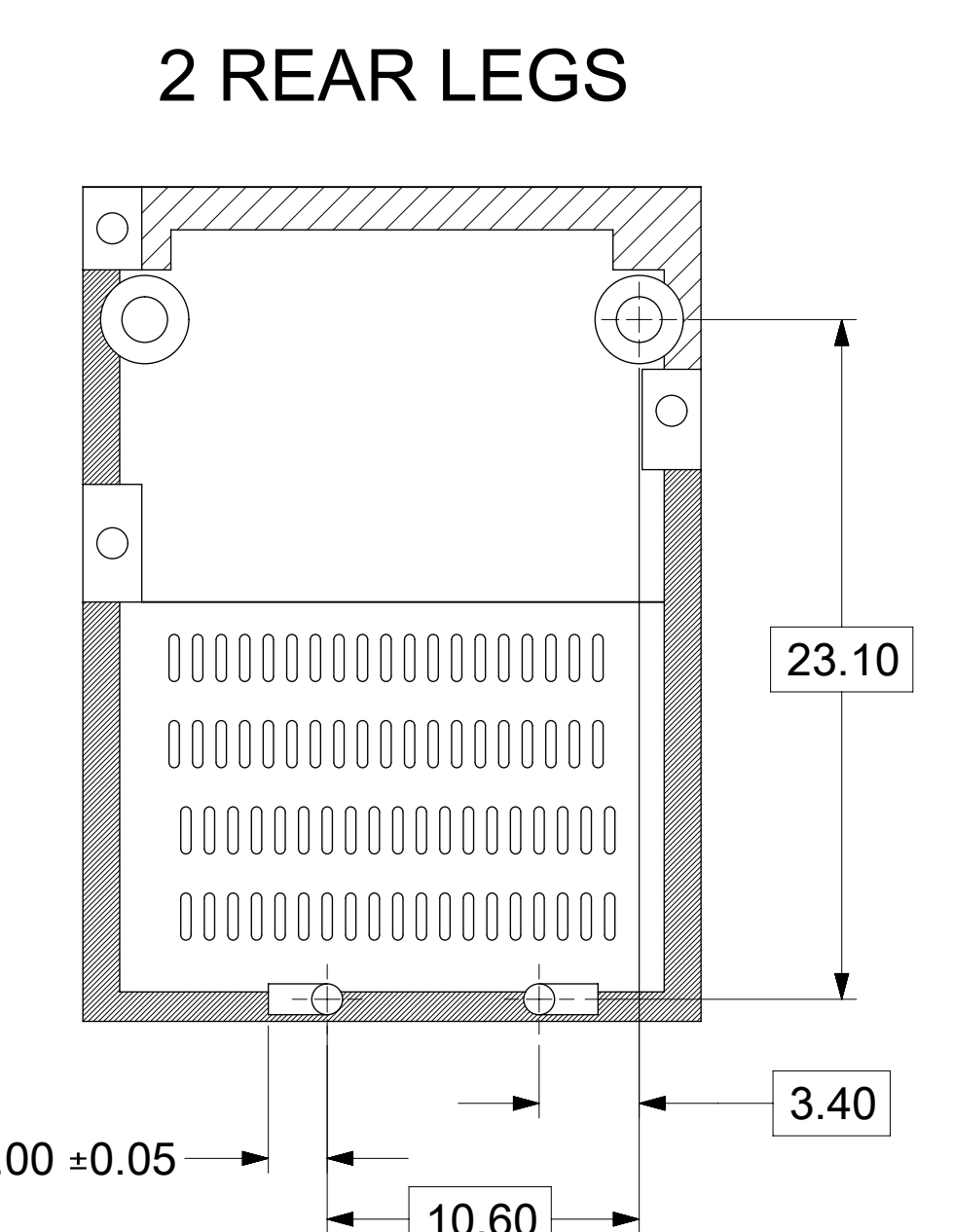
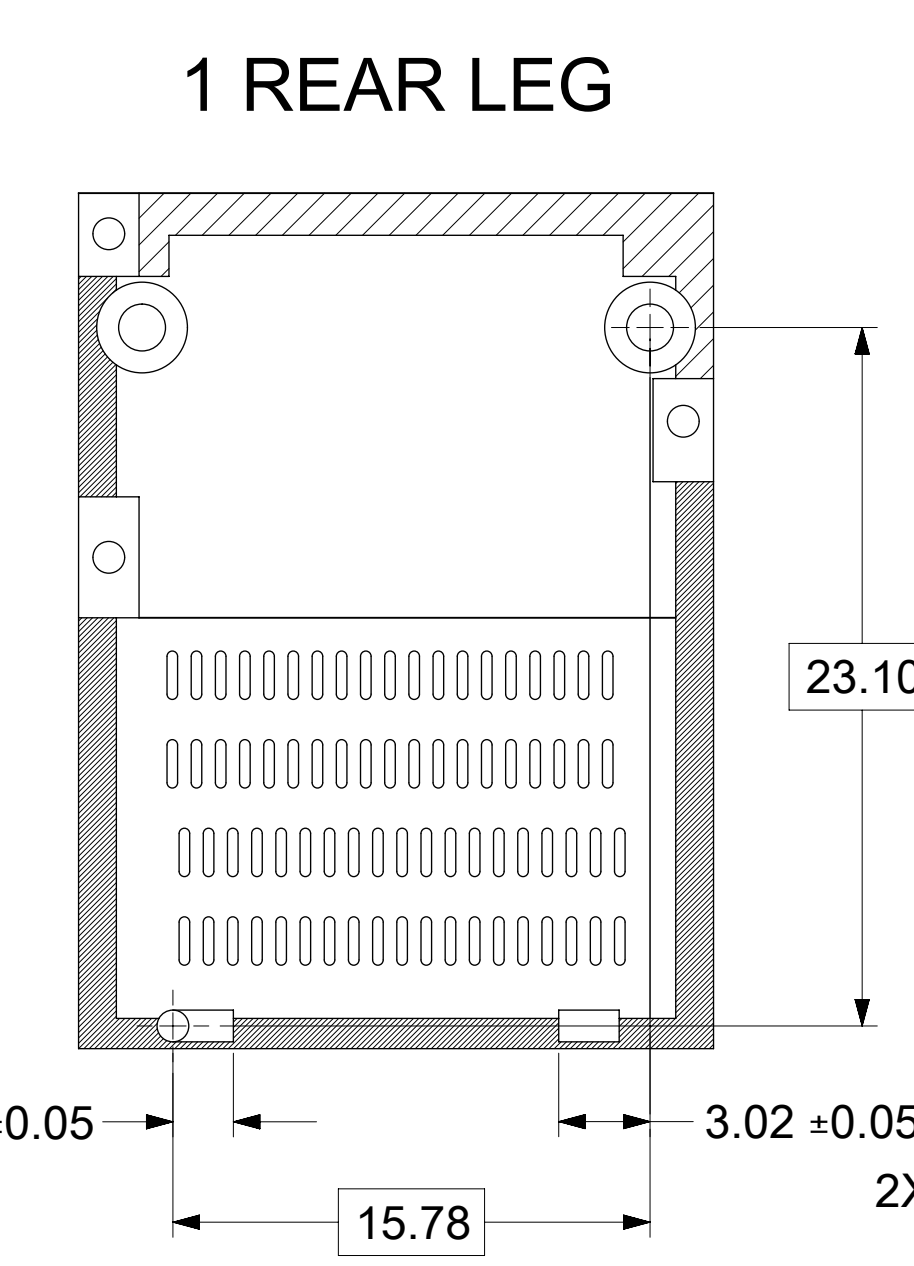
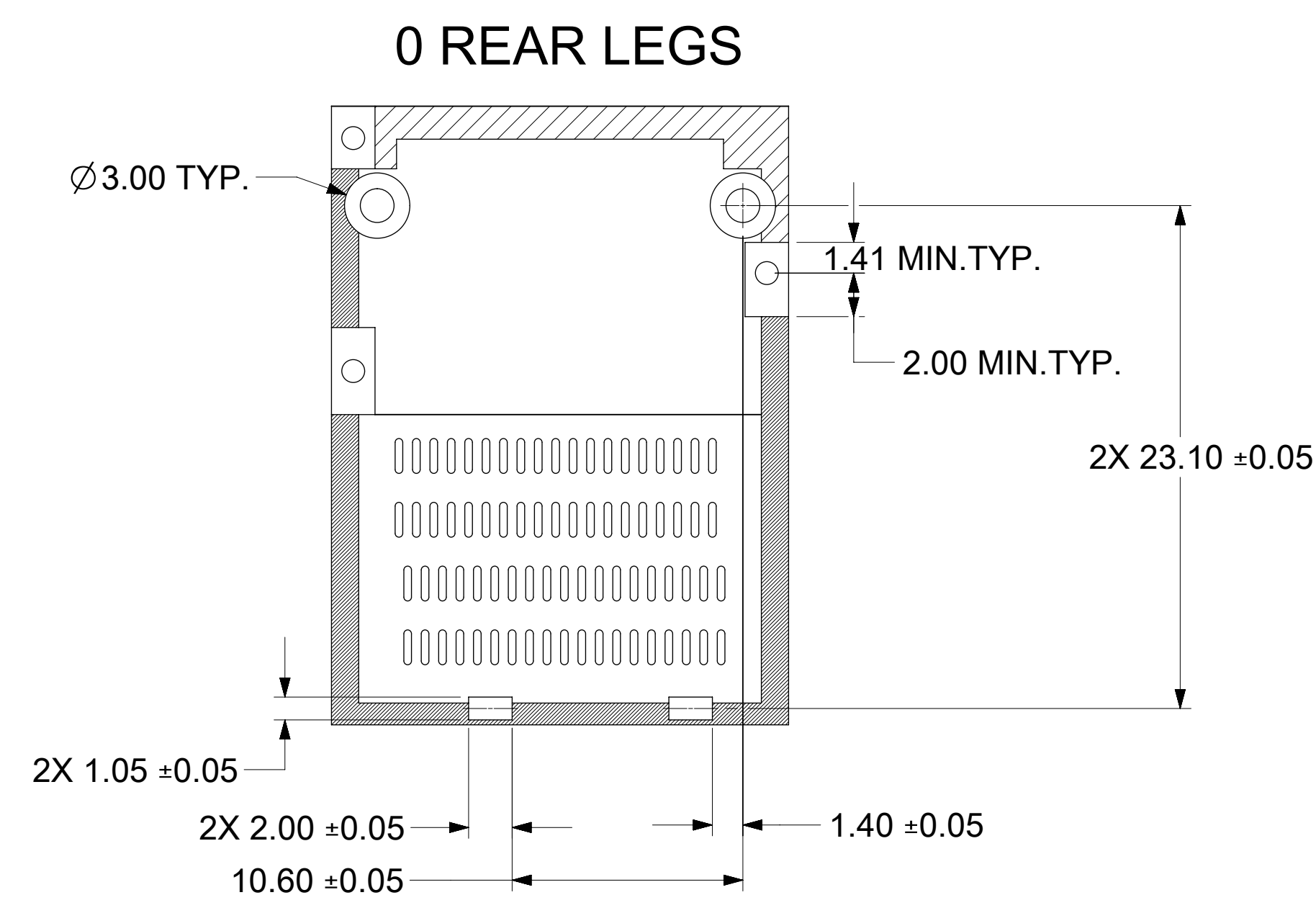
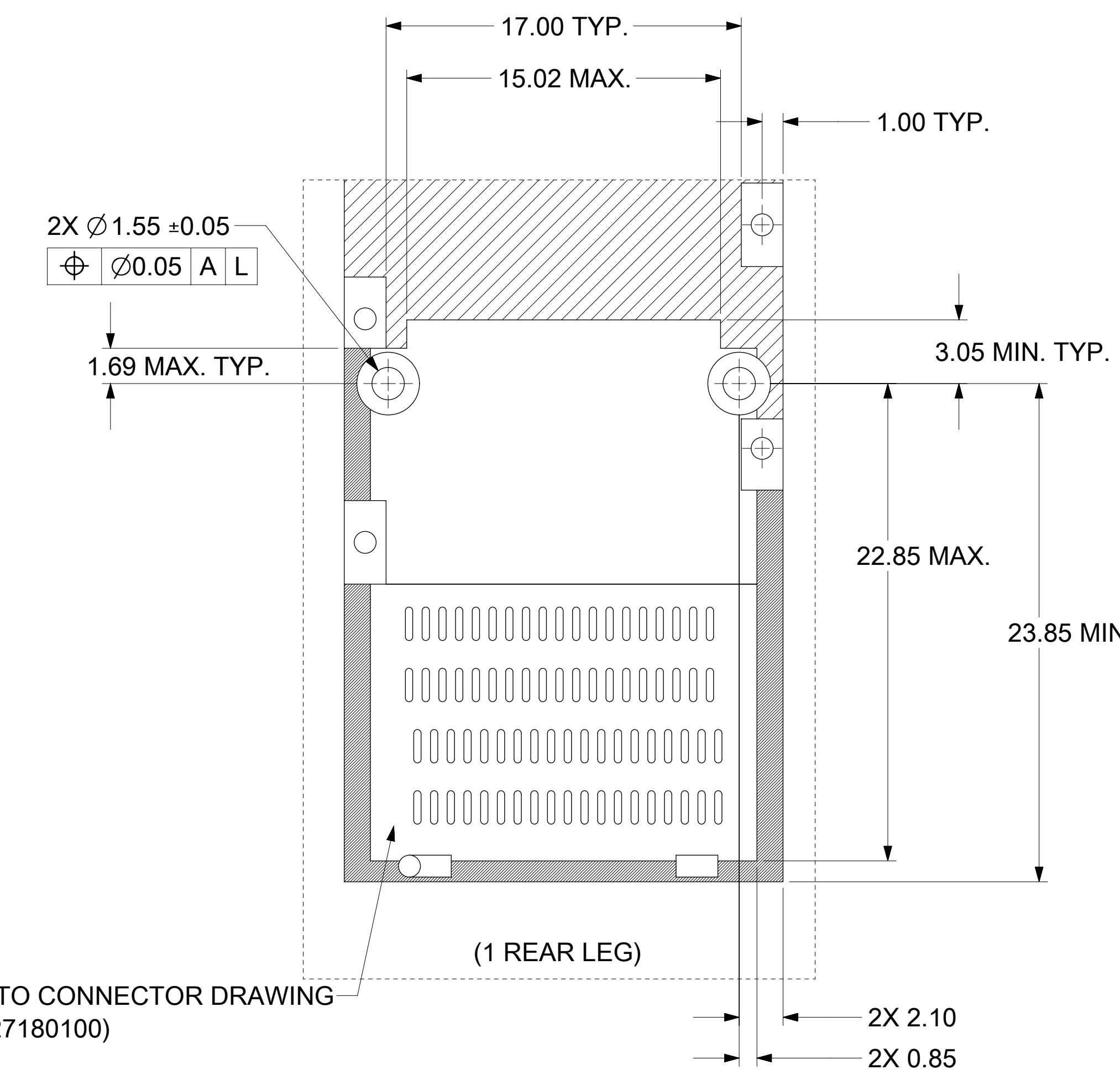
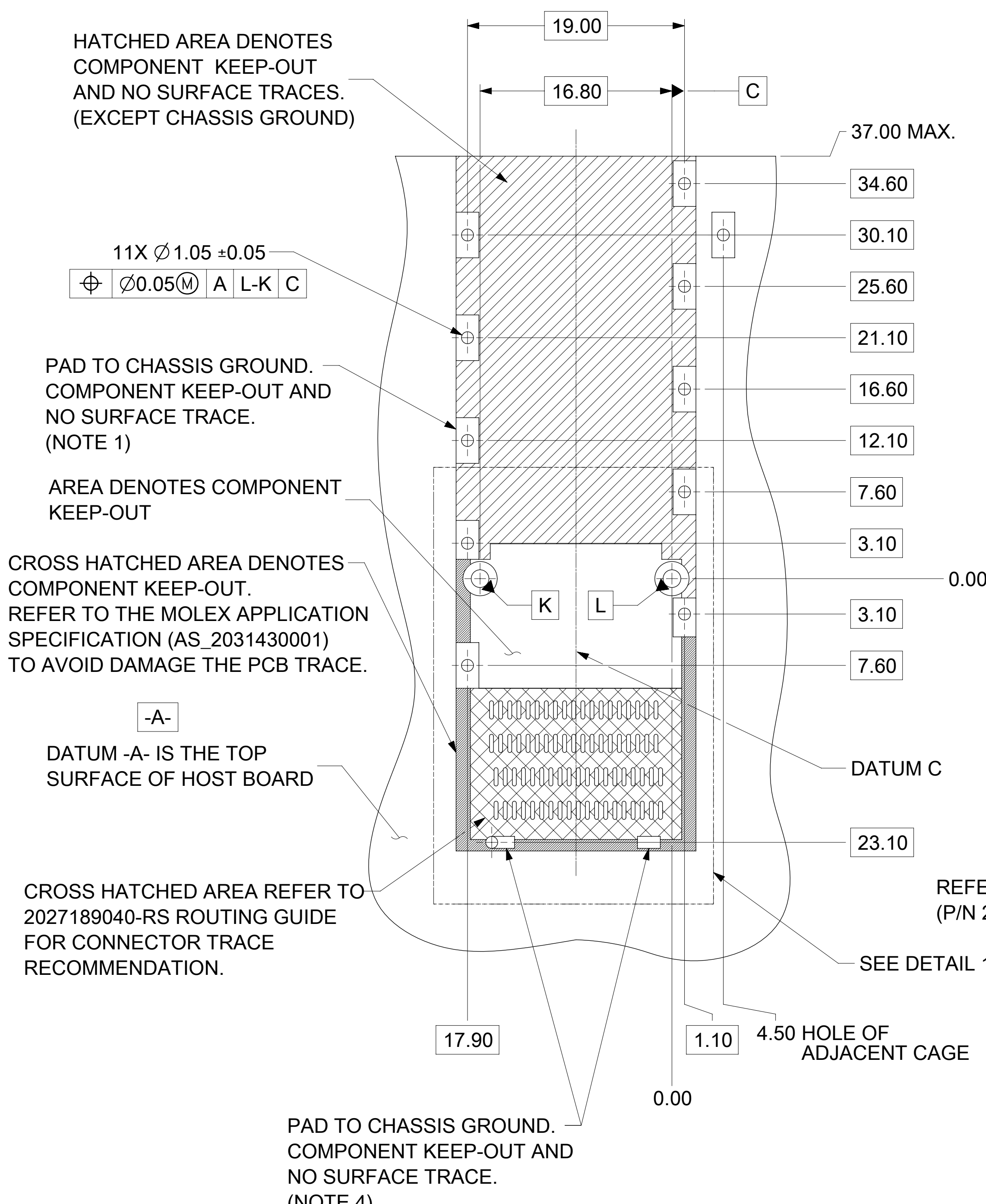

- NOTES:
1. PADS AND VIAS GO TO CHASSIS GROUND. (RECOMMENDED PADS TO BE 2.00x4.00mm RECTANGLE.)
 2. RECOMMENDED THRU HOLE PLATING INCLUDES HASL, OSP, OR IMMERSION (GOLD, SILVER, OR TIN).
 3. CONNECTOR PAD LAYOUT PER QSFP-DD MSA WILL ACCOMMODATE MOLEX CONNECTOR SERIES 202718.
 4. PADS AND VIAS GO TO CHASSIS GROUND.(RECOMMENDED PADS TO BE 1.05 x 2.00mm RECTANGLE)

THIS DRAWING CONTAINS INFORMATION THAT IS PROPRIETARY TO MOLEX ELECTRONIC TECHNOLOGIES, LLC AND SHOULD NOT BE USED WITHOUT WRITTEN PERMISSION									
DIMENSION UNITS		SCALE		CURRENT REV DESC: SEE REVISION TABLE					
mm		3.5:1							
GENERAL TOLERANCES (UNLESS SPECIFIED)									
ANGULAR TOL $\pm 2.0^\circ$									
4 PLACES \pm		EC NO: 705875		DRWN: MCHEN104		2022/08/04			
3 PLACES \pm		CHK'D: THSU02		APPR: SCHIEN		2022/08/05			
2 PLACES ± 0.13		INITIAL REVISION:		DRWN: SCHIEN		2019/06/10			
1 PLACE ± 0.25		APPR: JCHIANG		APPR: JCHIANG		2019/08/16			
0 PLACES \pm		THIRD ANGLE PROJECTION		DRAWING		SERIES		MATERIAL NUMBER	
DRAFT WHERE APPLICABLE MUST REMAIN WITHIN DIMENSIONS				D-SIZE		203143		SEE P/N TABLE	
DOCUMENT STATUS				CUSTOMER				SHEET NUMBER	
P1		RELEASE DATE		GENERAL MARKET		4 OF 7			
2022/08/08		12:39:21							

molex

QSFP-DD 1X1 CAGE ASSY
SF WITH FIN H/S OPTIONS

PRODUCT CUSTOMER DRAWING

DOCUMENT NUMBER: 2031433201
DOC TYPE: PSD
DOC PART: ASY
REVISION: A5

PCB LAYOUT FOR BELLY TO BELLY MOUNTING

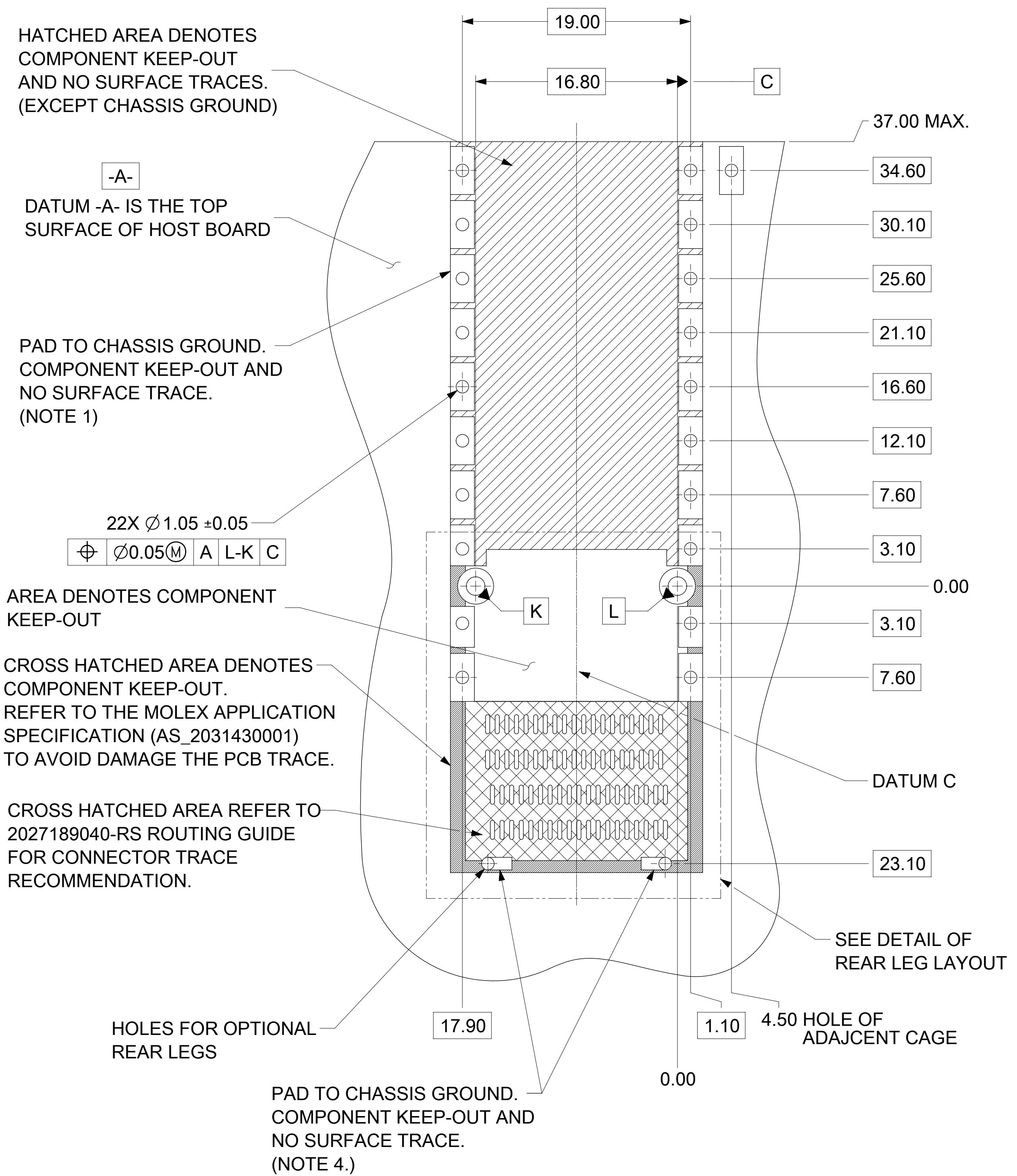

NOTE:
SEE SHEET 4 FOR
HOST CONNECTOR DETAIL

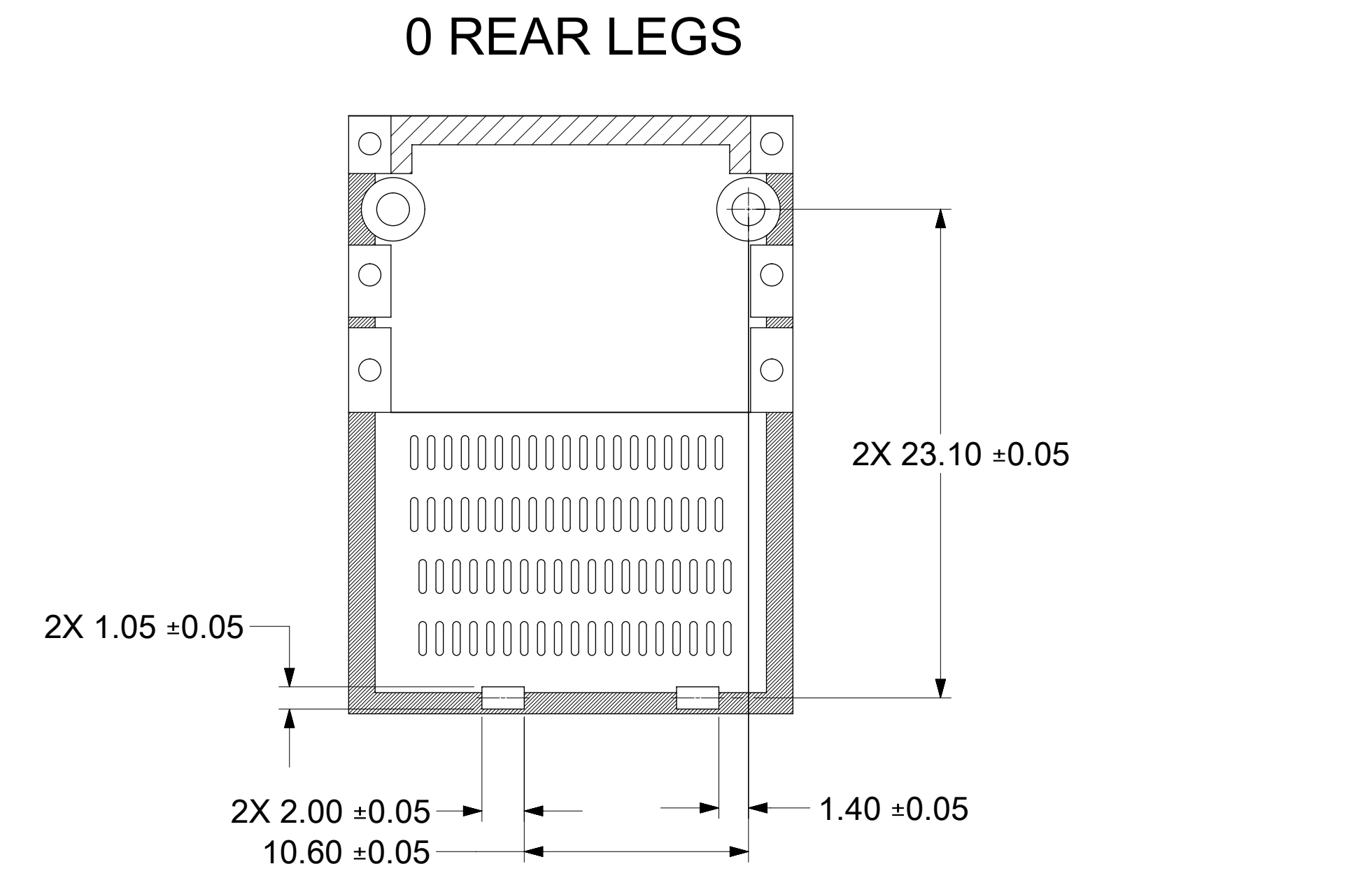

PARTIAL 1
SCALE 4:1

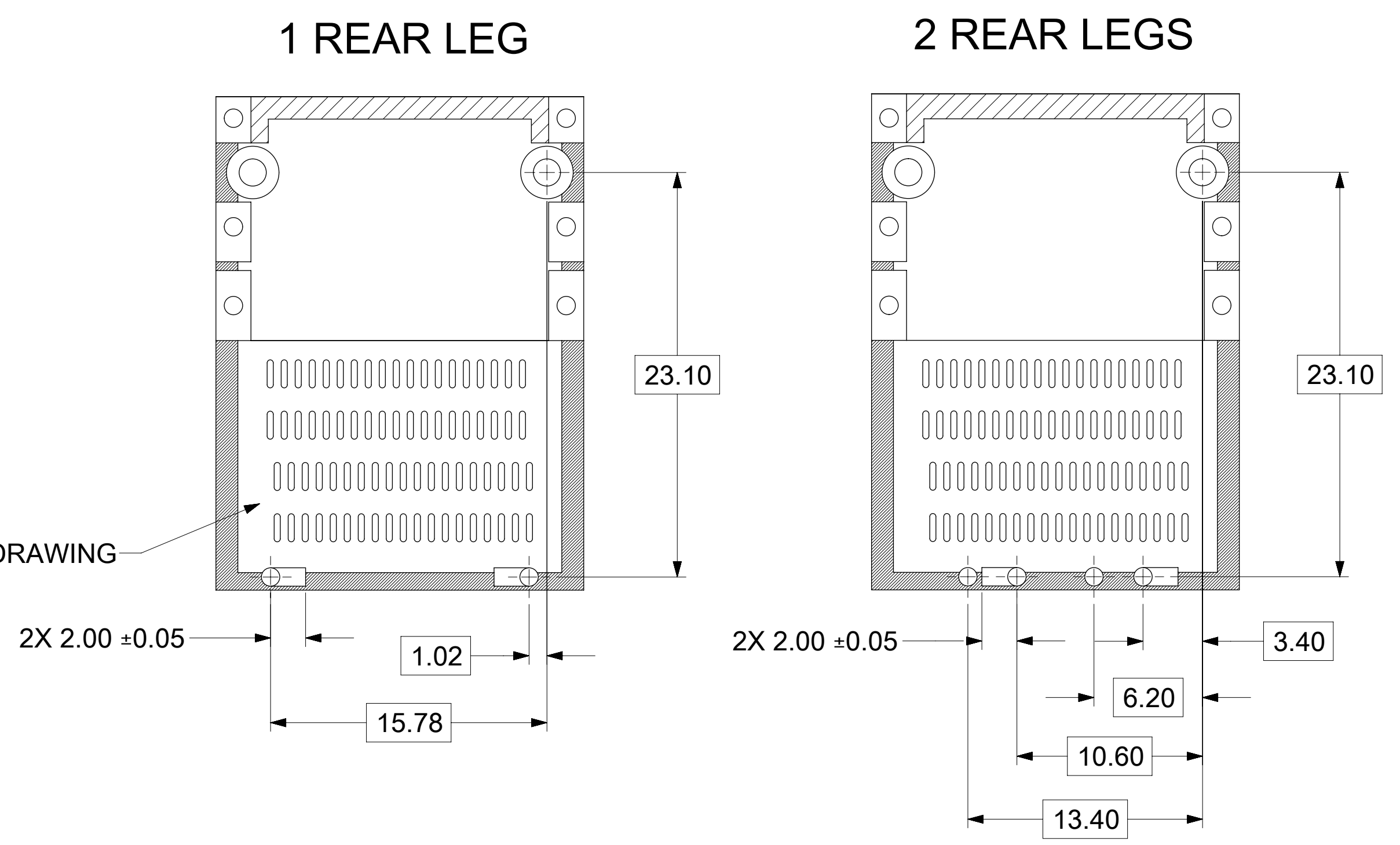

PARTIAL 2
SCALE 4:1

PARTIAL 3
SCALE 4:1

REFER TO CONNECTOR DRAWING
(P/N 2027180100)

- NOTES:
1. PADS AND VIAS GO TO CHASSIS GROUND. (RECOMMENDED PADS TO BE 2.00 x 4.00mm RECTANGLE.)
 2. RECOMMENDED THRU HOLE PLATING INCLUDES HASL, OSP, OR IMMERSION (GOLD, SILVER, OR TIN).
 3. CONNECTOR PAD LAYOUT PER QSFP-DD WILL ACCOMMODATE MOLEX CONNECTOR SERRIES 202718.
 4. PADS AND VIAS GO TO CHASSIS GROUND. (RECOMMENDED PADS TO BE 1.05 x 2.00mm RECTANGLE)

THIS DRAWING CONTAINS INFORMATION THAT IS PROPRIETARY TO MOLEX ELECTRONIC TECHNOLOGIES, LLC AND SHOULD NOT BE USED WITHOUT WRITTEN PERMISSION												
DIMENSION UNITS		SCALE		CURRENT REV DESC: SEE REVISION TABLE						molex		
mm		4:1										
GENERAL TOLERANCES (UNLESS SPECIFIED)				EC NO: 705875		2022/08/04		QSFP-DD 1X1 CAGE ASSY SF WITH FIN H/S OPTIONS				
ANGULAR TOL $\pm 2.0^\circ$				DRWN: MCHEN104		2022/08/05						
4 PLACES \pm				CHK'D: THSU02		2022/08/08		PRODUCT CUSTOMER DRAWING				
3 PLACES \pm				APPR: SCHIEN								
2 PLACES ± 0.13				INITIAL REVISION:				DOCUMENT NUMBER		DOC TYPE	DOC PART	REVISION
1 PLACE ± 0.25				DRWN: SCHIEN		2019/06/10		2031433201		PSD	ASY	A5
0 PLACES \pm				APPR: JCHIANG		2019/08/16		MATERIAL NUMBER		CUSTOMER		SHEET NUMBER
DRAFT WHERE APPLICABLE MUST REMAIN WITHIN DIMENSIONS				THIRD ANGLE PROJECTION		DRAWING		SERIES		GENERAL MARKET		5 OF 7
						D-SIZE		203143		SEE P/N TABLE		

BEZEL AND BOARD POSITION DIMENSIONS FOR BELLY TO BELLY MOUNTING

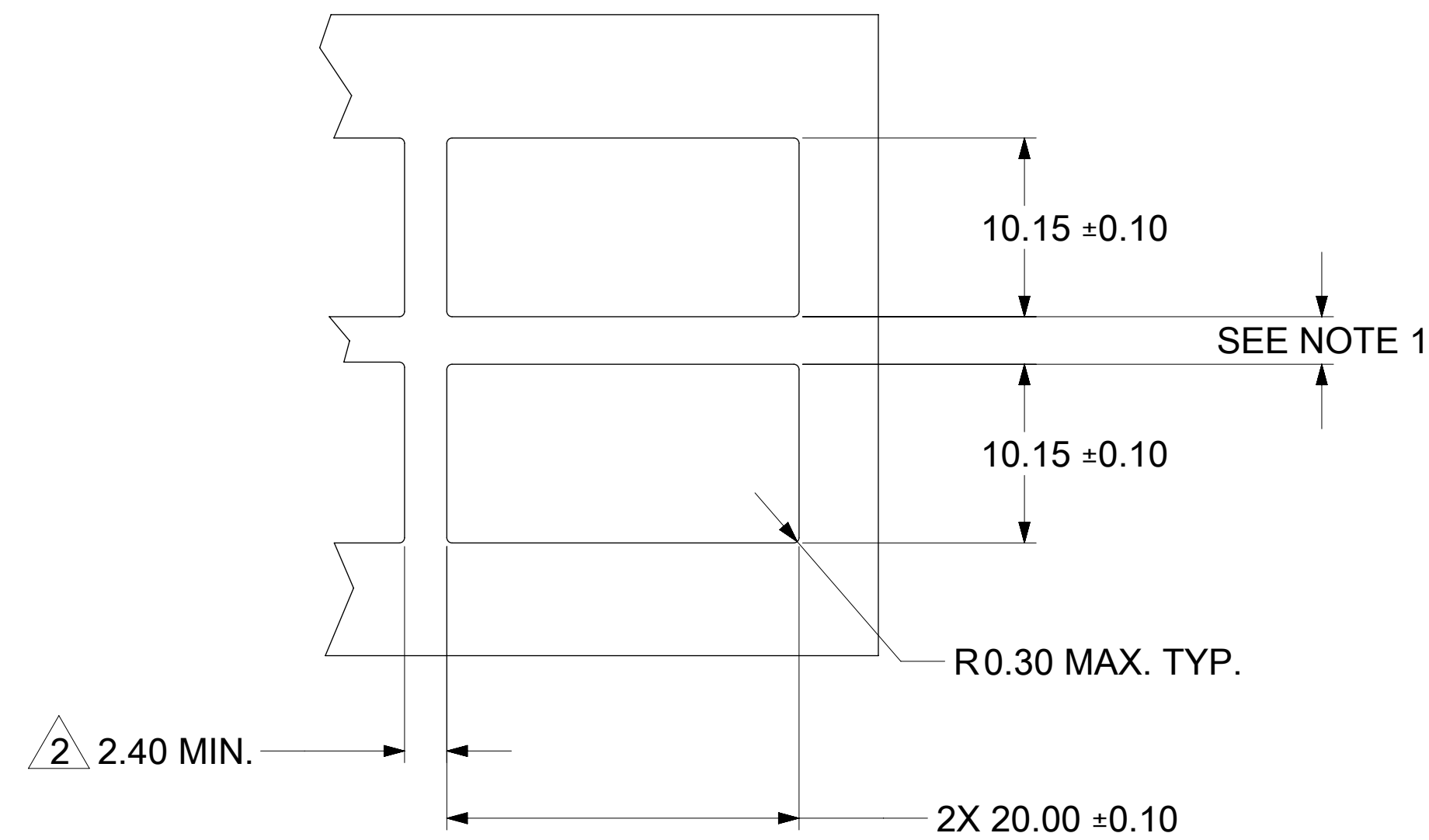
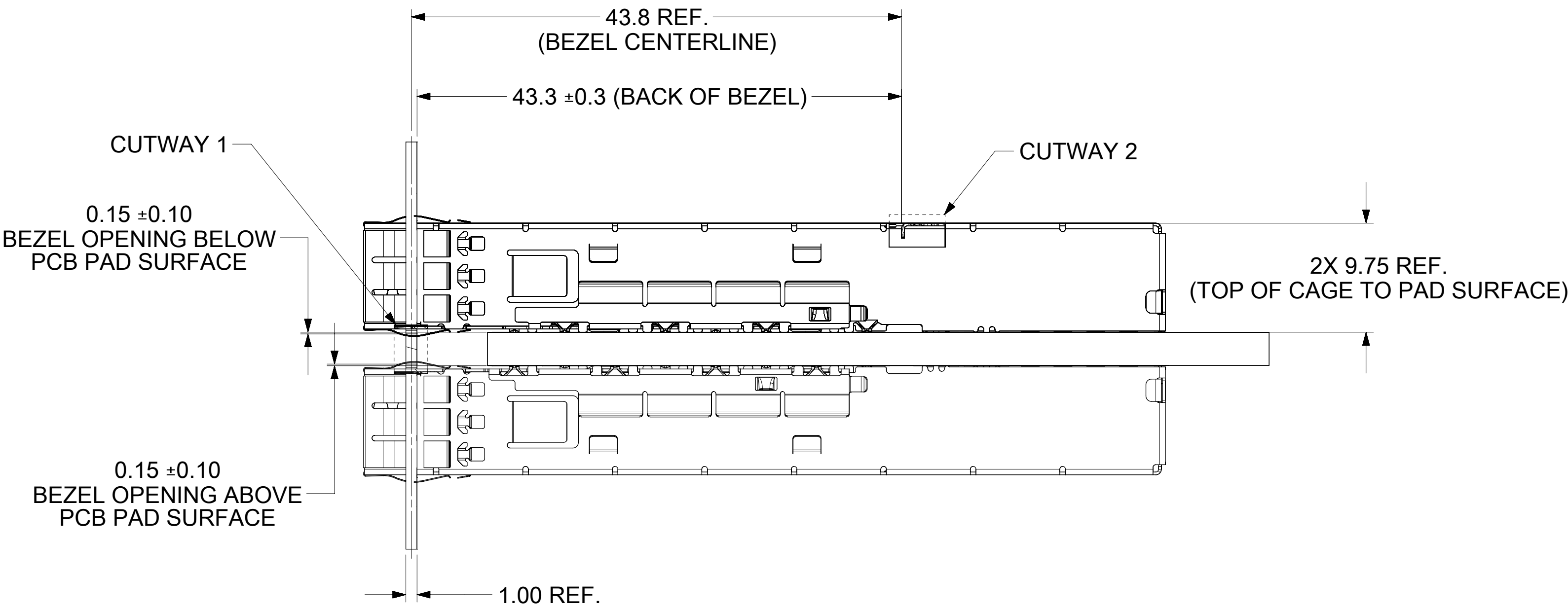

NOTE:
 1. PCB THICKNESS VARIATION MUST BE CONSIDERED WHEN DETERMINING BEZEL OPENING LOCATION.
 2. THIS DIMENSION IS FOR REFERENCE ONLY. USER CAN MODIFY IT DEPENDS ON APPLICATION.
 (THIS DIMENSION VARIES BASED ON DISTANCE OF "HOLE OF ADJACENT CAGE" ON PCB LAYOUT.)

BEZEL AND BOARD POSITION DIMENSIONS FOR SINGLE SIDE MOUNTING

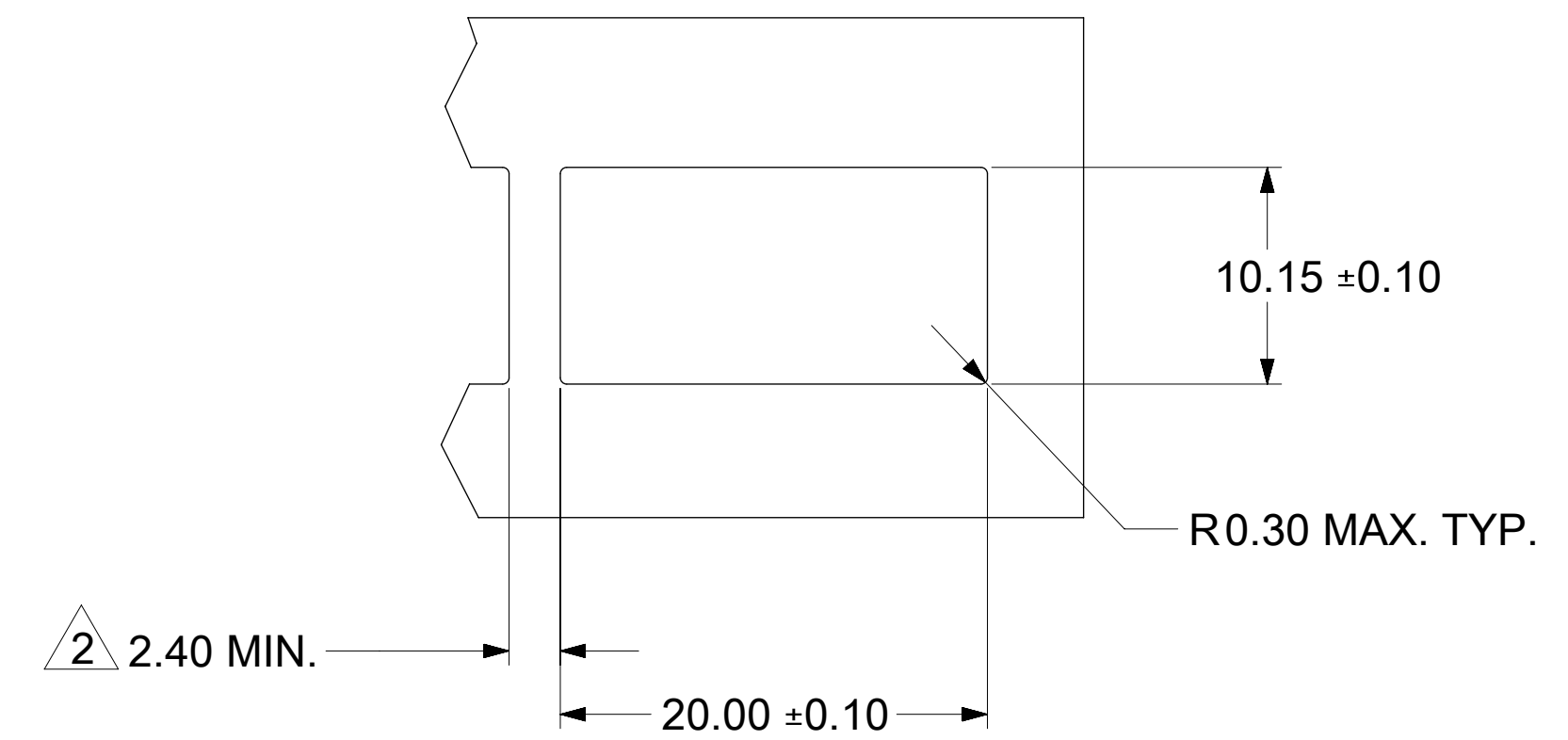
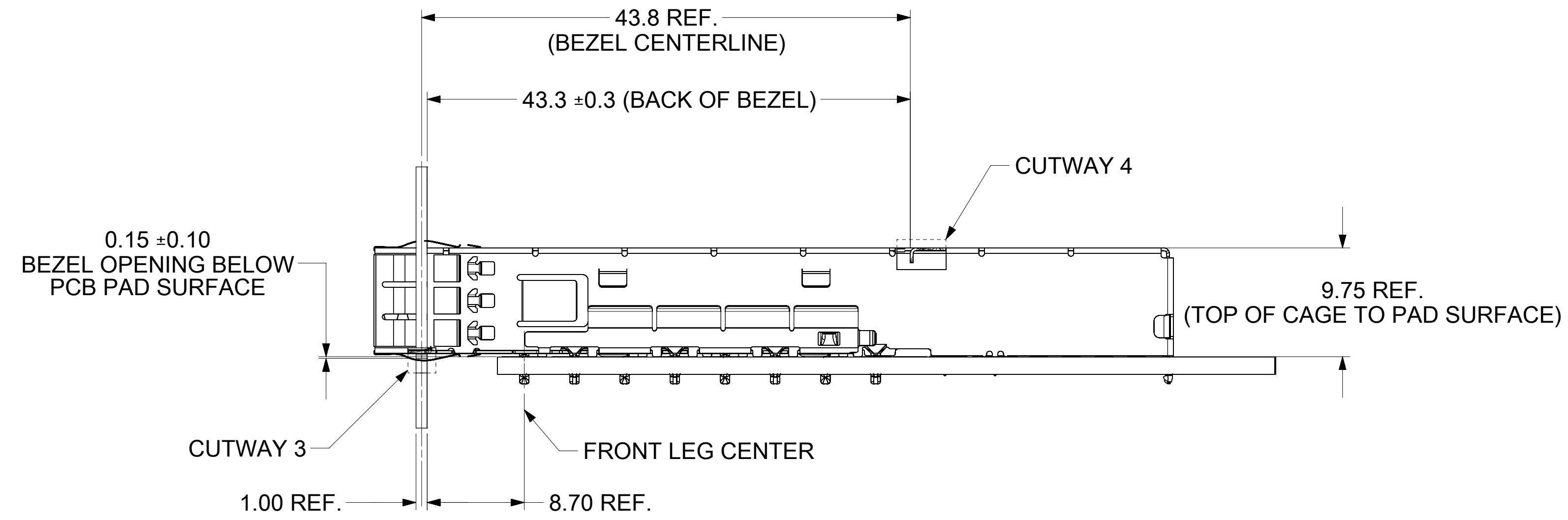

THIS DRAWING CONTAINS INFORMATION THAT IS PROPRIETARY TO MOLEX ELECTRONIC TECHNOLOGIES, LLC AND SHOULD NOT BE USED WITHOUT WRITTEN PERMISSION									
DIMENSION UNITS	SCALE	CURRENT REV DESC: SEE REVISION TABLE							
mm	3:1	<div style="text-align: center;">molex</div> QSFP-DD 1X1 CAGE ASSY SF WITH FIN H/S OPTIONS PRODUCT CUSTOMER DRAWING							
GENERAL TOLERANCES (UNLESS SPECIFIED)									
ANGULAR TOL	± 2.0°								
4 PLACES	±								
3 PLACES	±								
2 PLACES	± 0.13								
1 PLACE	± 0.25	EC NO: 705875	2022/08/04		DOCUMENT NUMBER: 2031433201 DOC TYPE: PSD DOC PART: ASY REVISION: A5				
0 PLACES	±	DRWN: MCHEN104	2022/08/05						
DRAFT WHERE APPLICABLE MUST REMAIN WITHIN DIMENSIONS		CHK'D: THSU02	2022/08/08						
THIRD ANGLE PROJECTION		APPR: SCHIEN	2022/08/08						
DRAWING SERIES		INITIAL REVISION:	2019/06/10		MATERIAL NUMBER: 2031433 CUSTOMER: GENERAL MARKET SHEET NUMBER: 6 OF 7				
D-SIZE		DRWN: SCHIEN	2019/08/16						
SEE P/N TABLE		APPR: JCHIANG	2019/08/16						

REV	DATE	DESCRIPTION
A	2019/07/17	INITIAL RELEASE
A1	2019/08/23	SHEET 6 : D4 & D14 : CHANGED R0.30 TYP. TO R0.30 MAX. TYP. SHEET 6 : G9 & G17 : CHANGED BEZEL THICKNESS FROM 1.60 REF. TO 1.00 REF. SHEET 6 : K6 & K16 : CHANGED FROM 43.0 ±0.3 TO 43.3 ±0.3 SHEET 6 : G7 : CHANGED FROM 8.40 REF. TO 8.70 REF.
A2	2020/05/20	SHEET 1 : CHANGED DEMONSTRATED CAGE FROM 2031433244 TO 2031433245 SHEET 3 : F18 : OBSOLETE 2031433244 SHEET 4 : K06 : ADDED Ø3.00 TYP. SHEET 4 : K03 : ADDED 1.41 MIN.TYP. AND 2.00 MIN.TYP.
A3	2020/09/24	SHEET 4 & SHEET 5 : ADD NOTE 4 OF REAR PAD INFORMTION.
A4	2022/05/06	SHEET 4: E19&G19 ADDED NEW NOTE ON CROSS HATCHED FOR KEEP OUT ZONE AND ROUTING GUIDE SHEET 5: E19&F19 ADDED NEW NOTE ON CROSS HATCHED FOR KEEP OUT ZONE AND ROUTING GUIDE
A5	2022/08/04	SHEET 1: E9: ADDED DIMENSION 1.73 SHEET 2 : ADDED DIM. "B" AND DIM. "C" AND TABLE

THIS DRAWING CONTAINS INFORMATION THAT IS PROPRIETARY TO MOLEX ELECTRONIC TECHNOLOGIES, LLC AND SHOULD NOT BE USED WITHOUT WRITTEN PERMISSION									
DIMENSION UNITS	SCALE	CURRENT REV DESC: SEE REVISION TABLE			molex				
mm	1:1								
GENERAL TOLERANCES (UNLESS SPECIFIED)					QSFP-DD 1X1 CAGE ASSY SF WITH FIN H/S OPTIONS				
ANGULAR TOL	± 2.0°				PRODUCT CUSTOMER DRAWING				
4 PLACES	±	EC NO: 705875							
3 PLACES	±	DRWN: MCHEN104 2022/08/04							
2 PLACES	± 0.13	CHK'D: THSU02 2022/08/05							
1 PLACE	± 0.25	APPR: SCHIEN 2022/08/08							
0 PLACES	±	INITIAL REVISION:							
DRAFT WHERE APPLICABLE MUST REMAIN WITHIN DIMENSIONS		DRWN: SCHIEN 2019/06/10			DOCUMENT NUMBER		DOC TYPE	DOC PART	REVISION
		APPR: JCHIANG 2019/08/16			2031433201		PSD	ASY	A5
		THIRD ANGLE PROJECTION			MATERIAL NUMBER		CUSTOMER		SHEET NUMBER
		DRAWING			203143		GENERAL MARKET		7 OF 7
		D-SIZE			SEE P/N TABLE				