

May.1.2023 Copyright 2023 HIROSE ELECTRIC CO., LTD. All Rights Reserved.
In case of consideration for using Automotive equipment / device which demand high reliability, kindly contact our sales window correspondents.

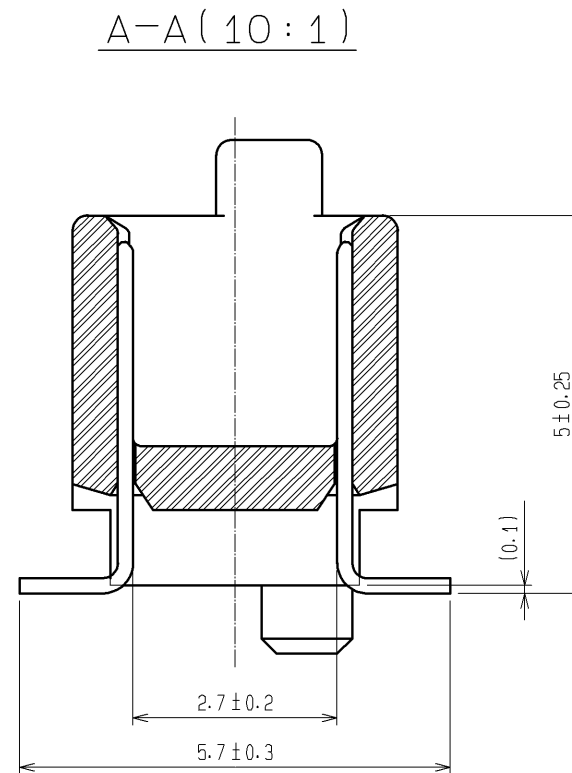

RECOMMENDED LAND PATTERN DIMENSION OF PCB(MOUNTING SIDE)

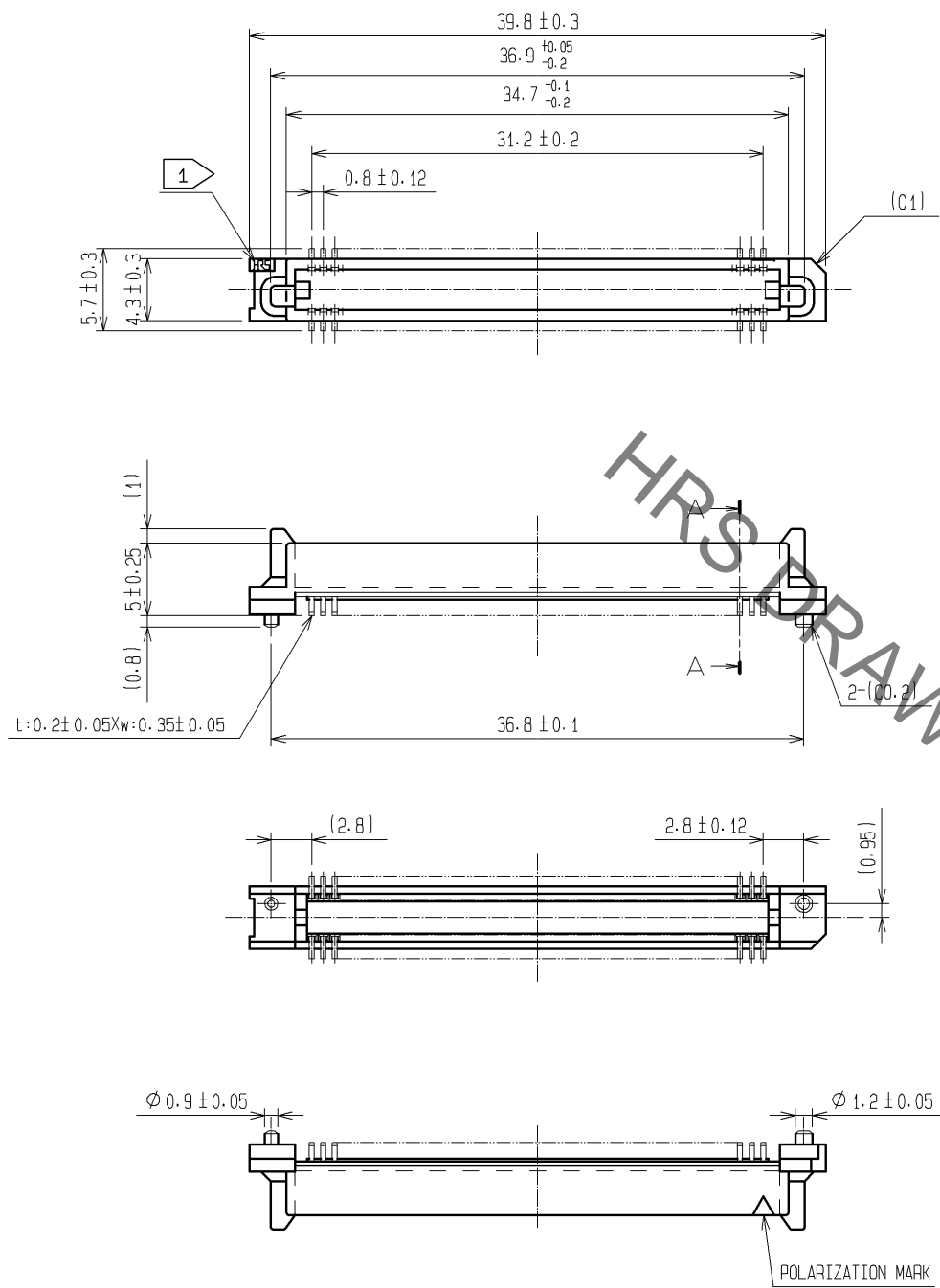
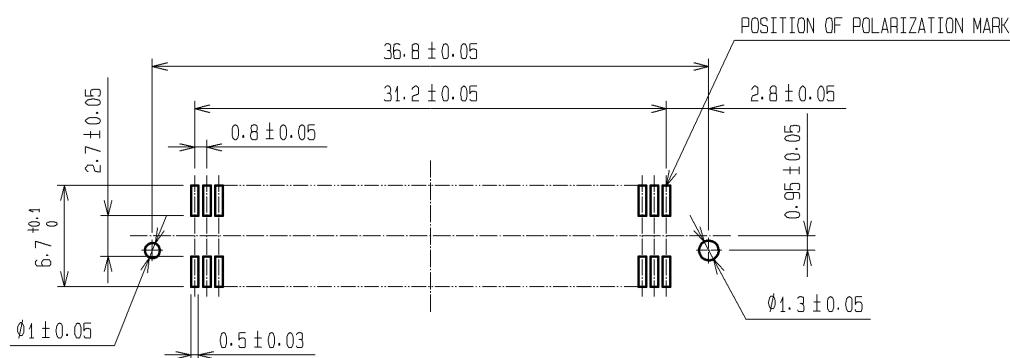

- NOTE
- 1 HRS MARK SHALL BE OPTIONAL.
 - 2 LEAD CO-PLANARITY SHALL BE 0.1mm MAX.
 - 3 EMBOSSED CARRIER TAPE PACKAGING SHALL BE APPLIED TO THIS PRODUCT. SEE NEXT PAGE FOR DETAILS.
 - 4 THIS PRODUCT HAS TAPE FOR VACUUM PICKUP. SEE NEXT PAGE FOR DETAIL OF STICKING POSITION, ETC.
 - 5 FOR MODIFICATION, ETC. PREVENTIVE HOLE FOR SINK MARK MAY BE ADDED ACCORDING TO CIRCUMSTANCES.
 - 6 THE DIMENSIONS IN PARENTHESES ARE FOR REFERENCE.

| | | | | | | | |
|--------------------------------------|----------|-----------------------|-----------|--------------------------|---|---------|------|
| 1 | PPS | LIGHT BROWN (UL94V-0) | 2 | PHOSPHOR BRONZE | CONTACT AREA:GOLD 0.1µm min. LEAD AREA:TIN-PLATING 1µm min. UNDER PLATING:NICKEL 1µm min. | | |
| NO. | MATERIAL | FINISH . REMARKS | NO. | MATERIAL | FINISH . REMARKS | | |
| UNITS mm | | SCALE 2 : 1 | COUNT | DESCRIPTION OF REVISIONS | DESIGNED | CHECKED | DATE |
| HRS HIROSE ELECTRIC CO., LTD. | | APPROVED : HS. OKAWA | 07.06.20 | DRAWING NO. | EDC3-084972-23 | | |
| | | CHECED : HS. OZAWA | 07.06.20 | PART NO. | FX6-80P-0.8SV1(93) | | |
| | | DESIGNED : KT. DOI | 07.06.20 | CODE NO. | CL576-0027-7-93 | | |
| | | DRAWN : TS. MIYAKI | 07.06.15 | | 1/2 | | |

May.1.2023 Copyright 2023 HIROSE ELECTRIC CO., LTD. All Rights Reserved.
 In case of consideration for using Automotive equipment / device which demand high reliability, kindly contact our sales window correspondents.

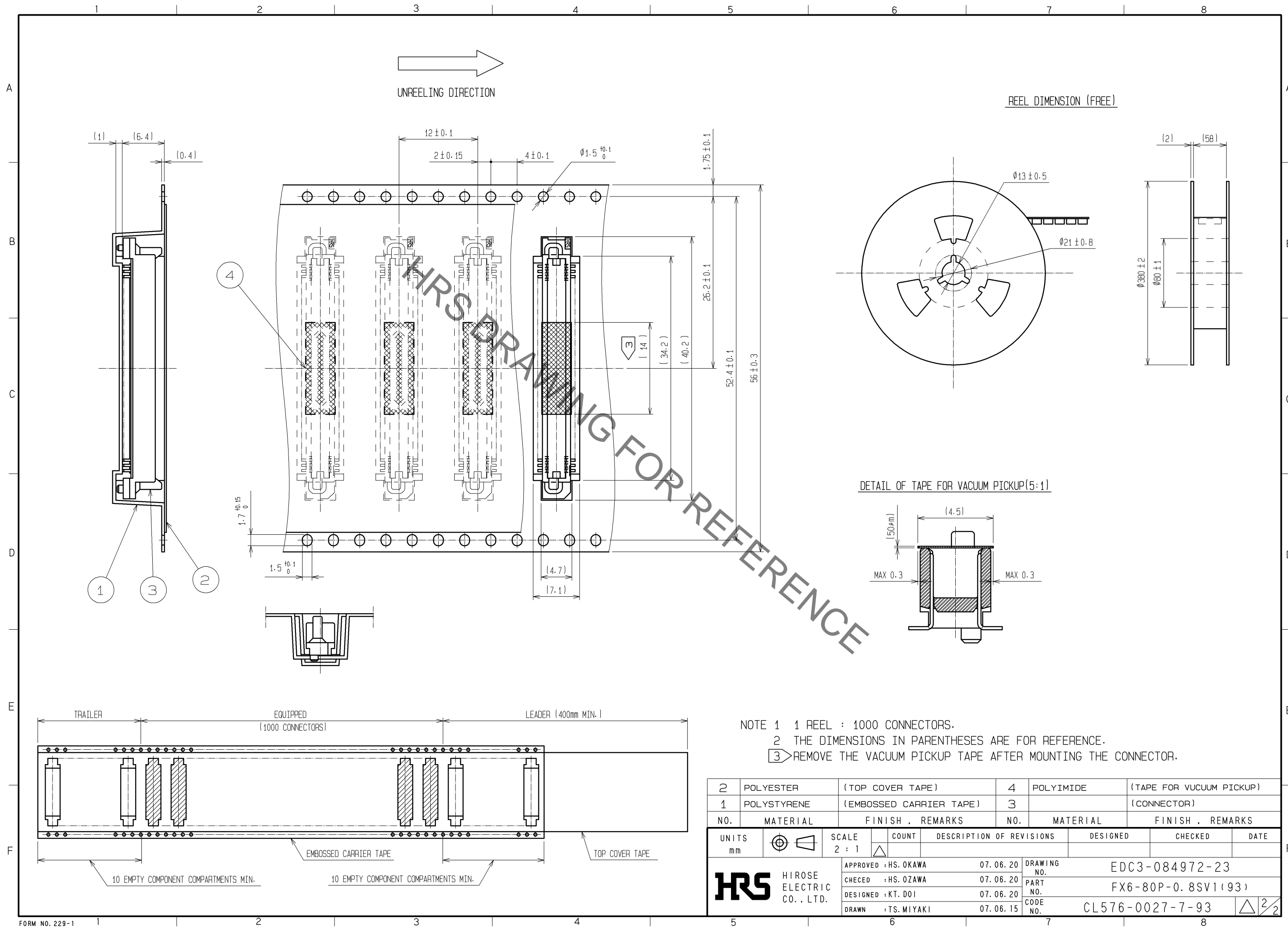

UNREELING DIRECTION

REEL DIMENSION (FREE)

DETAIL OF TAPE FOR VACUUM PICKUP(5:1)

NOTE 1 1 REEL : 1000 CONNECTORS.
 2 THE DIMENSIONS IN PARENTHESES ARE FOR REFERENCE.
 3 REMOVE THE VACUUM PICKUP TAPE AFTER MOUNTING THE CONNECTOR.

| | | | | | | | | |
|--------------------------------------|-------------|-------------------------|----------|-----------------------------|--------------------------|----------|---------|------|
| 2 | POLYESTER | (TOP COVER TAPE) | 4 | POLYIMIDE | (TAPE FOR VUCUUM PICKUP) | | | |
| 1 | POLYSTYRENE | (EMBOSSED CARRIER TAPE) | 3 | | (CONNECTOR) | | | |
| NO. | MATERIAL | FINISH . REMARKS | NO. | MATERIAL | FINISH . REMARKS | | | |
| UNITS mm | | SCALE 2 : 1 | | COUNT | DESCRIPTION OF REVISIONS | DESIGNED | CHECKED | DATE |
| HRS HIROSE ELECTRIC CO., LTD. | | APPROVED : HS. OKAWA | 07.06.20 | DRAWING NO. EDC3-084972-23 | | | | |
| | | CHECED : HS. OZAWA | 07.06.20 | PART NO. FX6-80P-0.8SV1(93) | | | | |
| | | DESIGNED : KT. DOI | 07.06.20 | CODE NO. CL576-0027-7-93 | | | | |
| | | DRAWN : TS. MIYAKI | 07.06.15 | | | | | |