

May.1.2023 Copyright 2023 HIROSE ELECTRIC CO., LTD. All Rights Reserved.  
In case of consideration for using Automotive equipment / device which demand high reliability, kindly contact our sales window correspondents.

Notes. 1. Recommended cable condition is shown below.  
 ⚠ A list of compatible cables is available on the Hirose website.  
 When using a non-recommended cable, please contact a Hirose sales representative.  
 Refer to the technical specification (ETAD-E3213) for wiring and assembly procedures.

⚠ Recommended Cable

Items		Recommended Condition
Conductor	Size	AWG#24 to 25
	Composition	7 stranded
	Material	Annealed copper wire
Insulation O. D.		φ1.1~1.25mm
Braid Shield		Tin plating
Sheath O. D.		φ6.3~7.2mm

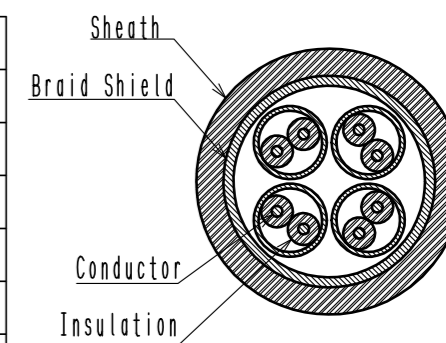

2. This product (Type B) is used for non Ethernet applications like signaling, serial or other industrial bus communication systems.  
 Please use Type A for 10/100 Mbit/s and 1/10 Gbit/s Ethernet communication.

⚠ Mating Key

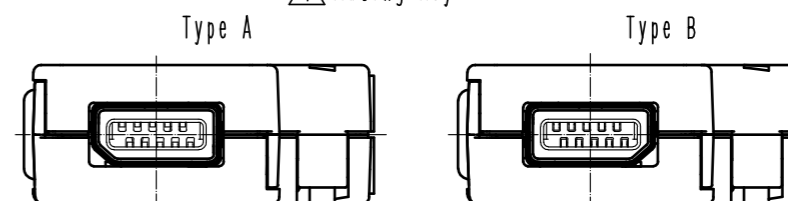

⚠ 3 Excluding the plug unit, this product is packaged separately by the type of parts.  
 The shield shell is packaged prior to bending. (See next page.)  
 Refer to the technical specification (ETAP-E3224) for packing.

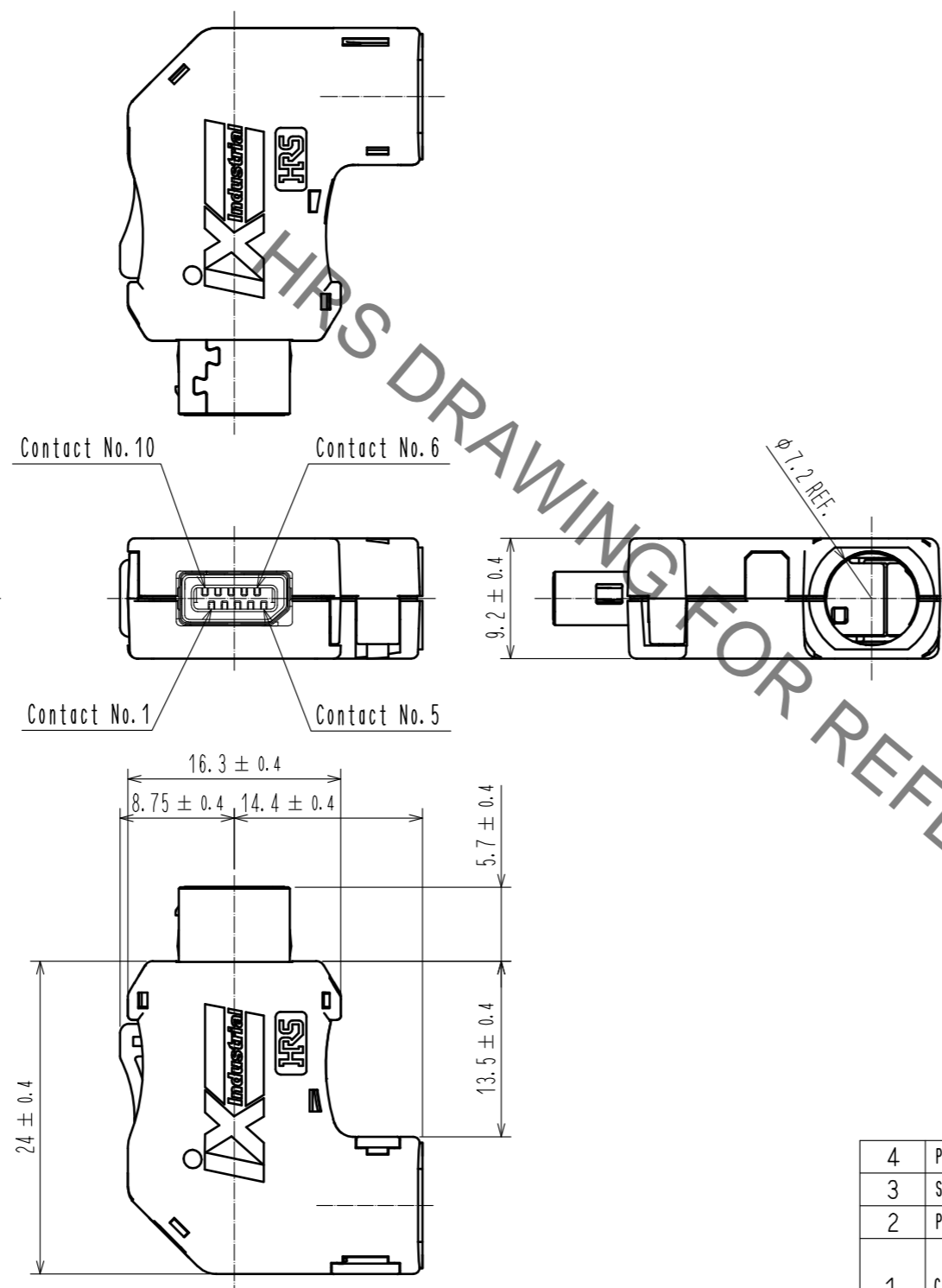

NO.	MATERIAL	FINISH	REMARKS	NO.	MATERIAL	FINISH	REMARKS
4	PA	Black	UL94V-0	9	PC	Dark gray	UL94V-0
3	Stainless Steel			8	PC	Dark gray	UL94V-0
2	PA	Dark gray	UL94V-0	7	Stainless Steel	Nickel 0.2 μm min	
1	Copper Alloy	Contact area : Palladium-Nickel 0.75 μm min + Gold 0.05 μm min		6	Stainless Steel	Nickel 1 μm min	
		Wiring area : Gold 0.03 μm min		5	PC	Clear yellow	UL94V-0
		Under plating : Nickel 2 μm min					

UNITS	SCALE	COUNT	DESCRIPTION OF REVISIONS	DESIGNED	CHECKED	DATE
mm	2 : 1	6	DIS-E-00006881	MT. YASUDA	KI. KAGOTANI	20211025

  

APPROVED	DATE	DRAWING NO.
•MN. KENJO	20200519	EDC-129982-01-00
•KI. NAGANUMA	20200519	PART NO. IX31G-B-10S-CVL2(7.0)(01)
•MT. YASUDA	20200519	
•MY. KOMUKAI	20200519	

DRAWN	DATE	CODE NO.
•MY. KOMUKAI	20200519	CL0251-0070-0-01

May.1.2023 Copyright 2023 HIROSE ELECTRIC CO., LTD. All Rights Reserved.  
 In case of consideration for using Automotive equipment / device which demand high reliability, kindly contact our sales window correspondents.

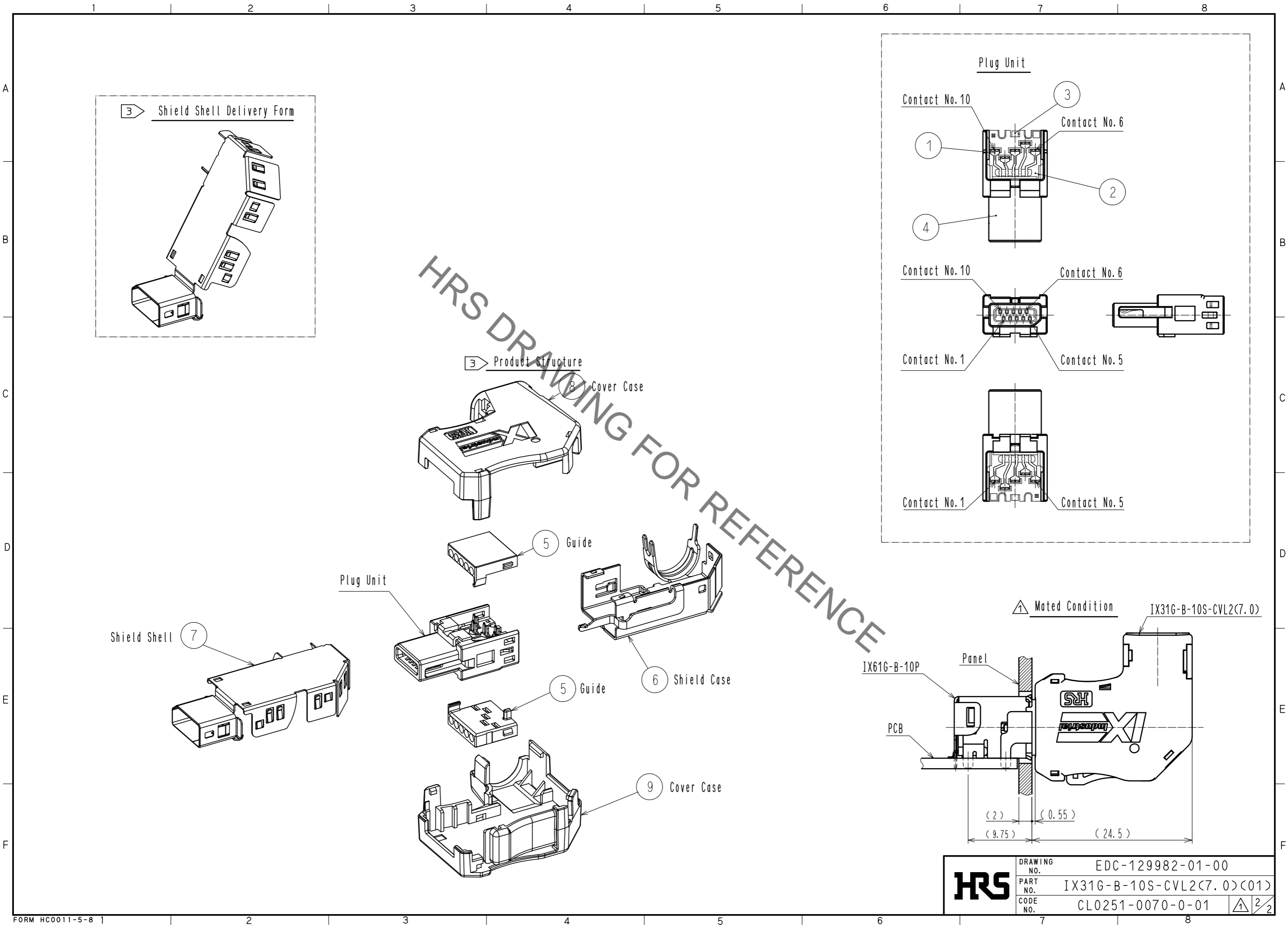

HRS DRAWING FOR REFERENCE

<b>HRS</b>	DRAWING NO.	EDC-129982-01-00
	PART NO.	IX31G-B-10S-CVL2(7.0)<01>
	CODE NO.	CL0251-0070-0-01
		△ 2/2