



## Main

Range Compatibility	Lexium 28
Product or Component Type	Servo motor
Device short name	BCH2

## Complementary

Maximum mechanical speed	3000 rpm
[Us] rated supply voltage	220 V
Phase	Single phase Three phase
Continuous stall current	6.18 A
Continuous stall torque	63.37 Lbf.In (7.16 N.m) LXM26D 7 A, 220 V, single phase 63.37 Lbf.In (7.16 N.m) LXM26D 7 A, 220 V, three phase 63.37 Lbf.In (7.16 N.m) LXM28... 7 A, 220 V, single phase 63.37 lbf.in (7.16 N.m) LXM28... 7 A, 220 V, three phase
Continuous power	1500 W
Peak stall torque	190.11 Lbf.In (21.48 N.m) LXM26D 7 A, 220 V, single phase 190.11 Lbf.In (21.48 N.m) LXM26D 7 A, 220 V, three phase 190.11 Lbf.In (21.48 N.m) LXM28... 7 A, 220 V, single phase 190.11 lbf.in (21.48 N.m) LXM28... 7 A, 220 V, three phase
Nominal output power	1500 W LXM26D 7 A, 220 V, single phase 1500 W LXM26D 7 A, 220 V, three phase 1500 W LXM28... 7 A, 220 V, single phase 1500 W LXM28... 7 A, 220 V, three phase
Nominal torque	63.37 Lbf.In (7.16 N.m) LXM26D 7 A, 220 V, single phase 63.37 Lbf.In (7.16 N.m) LXM26D 7 A, 220 V, three phase 63.37 Lbf.In (7.16 N.m) LXM28... 7 A, 220 V, single phase 63.37 lbf.in (7.16 N.m) LXM28... 7 A, 220 V, three phase
Nominal speed	2000 rpm LXM26D 7 A, 220 V, single phase 2000 rpm LXM26D 7 A, 220 V, three phase 2000 rpm LXM28... 7 A, 220 V, single phase 2000 rpm LXM28... 7 A, 220 V, three phase
Maximum current Irms	20.31 A LXM28... 1.5 kW, 220 V
Maximum permanent current	6.74 A
Product compatibility	LXM26D servo drive 1.5 kW, 220 V, single phase LXM26D servo drive 1.5 kW, 220 V, three phase LXM28... servo drive 1.5 kW, 220 V, single phase LXM28... servo drive 1.5 kW, 220 V, three phase
Shaft end	Keyed
Shaft diameter	0.87 in (22 mm)
Shaft length	2.17 in (55 mm)
Key width	0.31 in (8 mm)
Feedback type	20 bits single turn absolute encoder
Holding brake	With
Holding torque	84.97 lbf.in (9.6 N.m) built-in
Mounting Support	Asian standard flange

Motor flange size	5.12 in (130 mm)
Electrical connection	Connector MIL
Torque constant	1.16 N.m/A 68 °F (20 °C)
Back emf constant	70 V/krpm 68 °F (20 °C)
Rotor inertia	10 kg.cm <sup>2</sup>
Stator resistance	0.64 Ohm 68 °F (20 °C)
Stator inductance	6.4 mH 68 °F (20 °C)
Stator electrical time constant	10 ms 68 °F (20 °C)
Maximum radial force Fr	670 N 2000 rpm
Maximum axial force Fa	200 N
Brake pull-in power	19.7 W
Type of cooling	Natural convection
Length	7.95 in (202 mm)
Number of motor stacks	3
Centring collar diameter	4.33 in (110 mm)
Centring collar depth	0.31 in (8 mm)
Number of mounting holes	4
Mounting holes diameter	0.36 in (9.2 mm)
Circle diameter of the mounting holes	5.71 in (145 mm)
Distance shaft shoulder-flange	0.31 in (8 mm)
Net Weight	19.40 lb(US) (8.8 kg)

## Environment

IP Degree of Protection	IP50 IM V3 IP65 IM B5, IM V1
Ambient air temperature for operation	32...104 °F (0...40 °C)

## Ordering and shipping details

Category	22000 - Temporary Category for ITS Price Promotion
Discount Schedule	I
GTIN	3606480734359
Nbr. of units in pkg.	1
Package weight(Lbs)	23.61 lb(US) (10.71 kg)
Returnability	No
Country of origin	CN

## Packing Units

Unit Type of Package 1	PCE
Package 1 Height	7.56 in (19.2 cm)
Package 1 width	9.17 in (23.3 cm)
Package 1 Length	14.21 in (36.1 cm)
Unit Type of Package 2	S06
Number of Units in Package 2	9
Package 2 Weight	212.50 lb(US) (96.39 kg)
Package 2 Height	28.94 in (73.5 cm)
Package 2 width	23.62 in (60 cm)
Package 2 Length	31.50 in (80 cm)

## Offer Sustainability

Sustainable offer status	Green Premium product
California proposition 65	WARNING: This product can expose you to chemicals including: Lead and lead compounds, which is known to the State of California to cause cancer and birth defects or other reproductive harm. For more information go to <a href="http://www.P65Warnings.ca.gov">www.P65Warnings.ca.gov</a>
REACH Regulation	<a href="#">REACH Declaration</a>
REACH free of SVHC	Yes
EU RoHS Directive	Pro-active compliance (Product out of EU RoHS legal scope) <a href="#">EU RoHS Declaration</a>
Mercury free	Yes
RoHS exemption information	<a href="#">Yes</a>
China RoHS Regulation	<a href="#">China RoHS Declaration</a>
Environmental Disclosure	<a href="#">Product Environmental Profile</a>
Circularity Profile	<a href="#">End Of Life Information</a>
WEEE	The product must be disposed on European Union markets following specific waste collection and never end up in rubbish bins.
PVC free	Yes

Dimensions

Dimensions of Motor

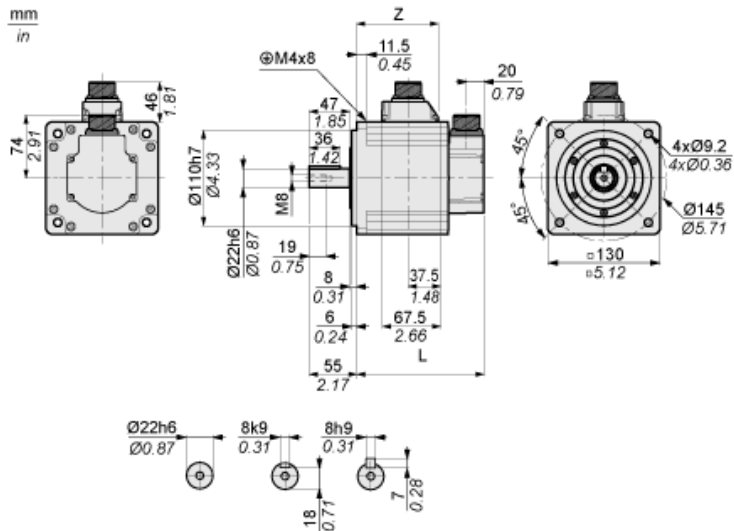

	mm	in.
L (without holding brake)	167	6.57
L (with holding brake)	202	7.95
Z	114.5	4.51

Torque/Speed Curves with 230 V Single/Three Phase Supply Voltage

Servo Motor with LXM28AU15●●● Servo Drive

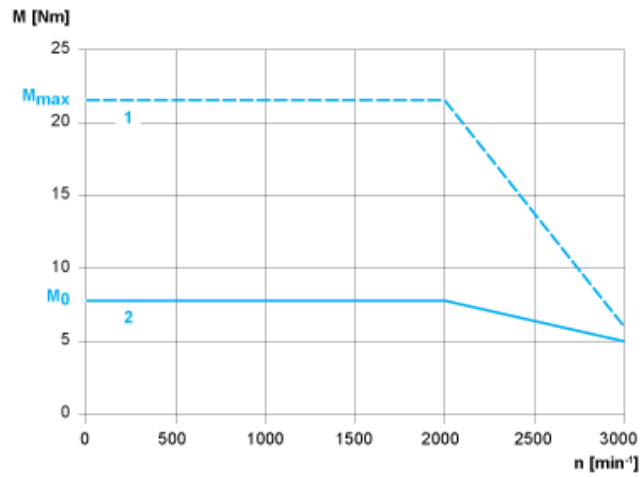

- 1 : Peak torque
- 2 : Continuous torque