

May.1.2023 Copyright 2023 HIROSE ELECTRIC CO., LTD. All Rights Reserved.
In case of consideration for using Automotive equipment / device which demand high reliability, kindly contact our sales window correspondents.

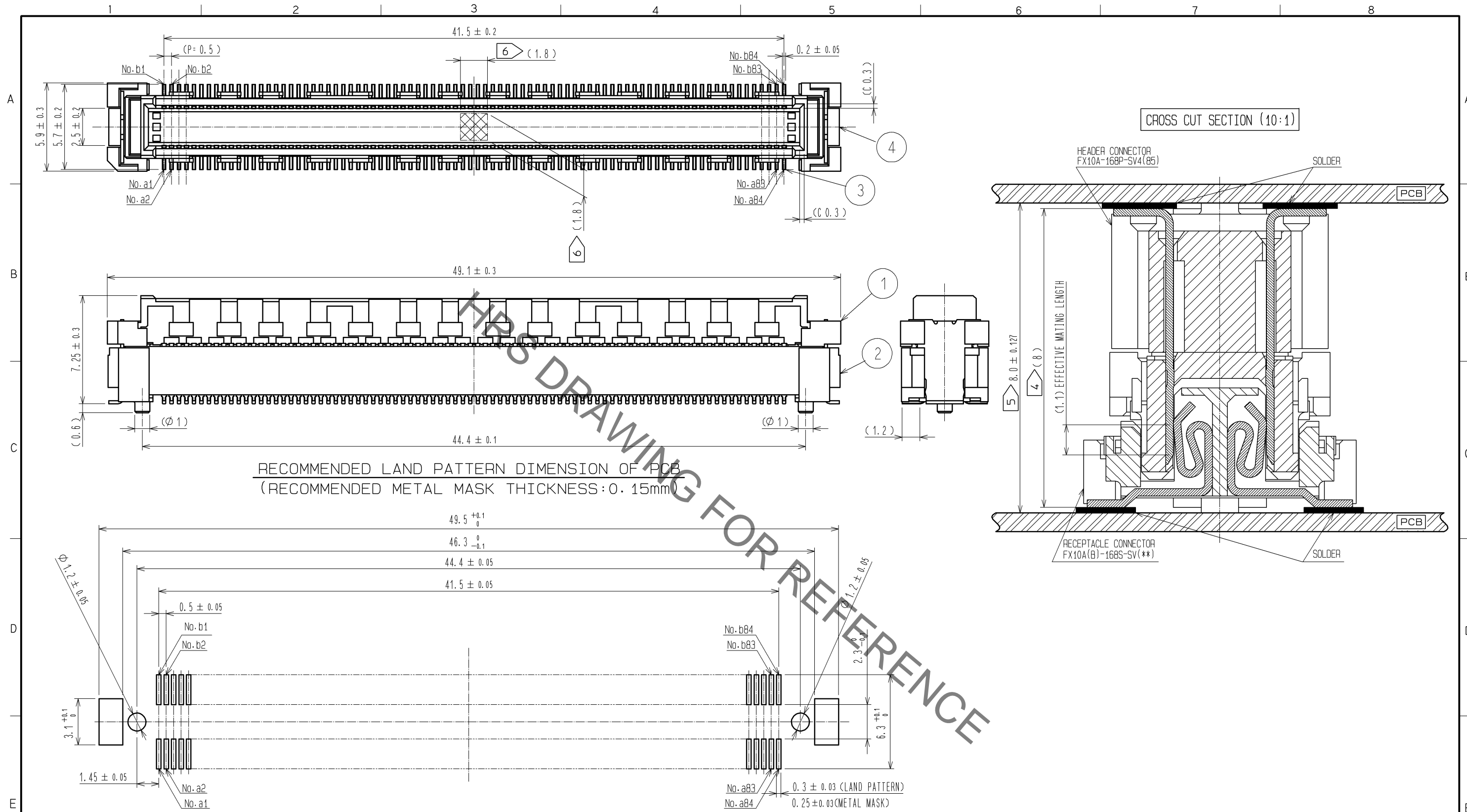

- NOTES
- 1 SMT LEAD-COPLANARITY: 0.1 MAX.
 - 2 THIS PRODUCT HAS NO POLARITY TO PATTERN FOR MOUNTING.
 - 3 THE DIMENSIONS IN PARENTHESES ARE FOR REFERENCE.
 - 4 STACKING HEIGHT FROM LEAD TO LEAD(REFERENCE DIMENSIONS)
 - 5 BOARD DISTANCE
 - 6 AREA IS VACUUM PICKUP AREA FOR REFERENCE.
 - 7 EMBOSS CARRIER TAPE PACKAGE IS APPLIED ON THIS PRODUCT. PLEASE REFER TO THE SHEET 2/2 FOR THE RETAILS.

3	COPPER ARROY	CONTACT AREA:GOLD 0.76μm min.	6	PET	TOP COVER TAPE			
		LEAD AREA:GOLD 0.03μm min.	5	PS	EMBOSSED CARRIER TAPE			
		UNDER PLATING:NICKEL 1.3μm min.	4	COPPER ARROY	SURFACE AREA:GOLD 0.03μm min. UNDER PLATING:NICKEL 1.3μm min.			
1, 2	LCP	BEIGE UL94V-0						
NO.	MATERIAL	FINISH . REMARKS	NO.	MATERIAL	FINISH . REMARKS			
UNITS mm			SCALE 4 : 1	COUNT	DESCRIPTION OF REVISIONS	DESIGNED	CHECKED	DATE
HRS HIROSE ELECTRIC CO., LTD.		APPROVED : HS. OKAWA	13. 10. 10	DRAWING NO.	EDC3-330883-25			
		CHECKED : HT. YAMAGUCHI	13. 10. 10	PART NO.	FX10A-168P-SV4(85)			
		DESIGNED : YJ. ASAO	13. 10. 10	CODE NO.	CL570-0306-2-85			
		DRAWN : YJ. ASAO	13. 10. 10		1/2			

May.1.2023 Copyright 2023 HIROSE ELECTRIC CO., LTD. All Rights Reserved.
 In case of consideration for using Automotive equipment / device which demand high reliability, kindly contact our sales window correspondents.

DRAWING FOR PACKING(2:1)

REELED DIMENSION(FREE)

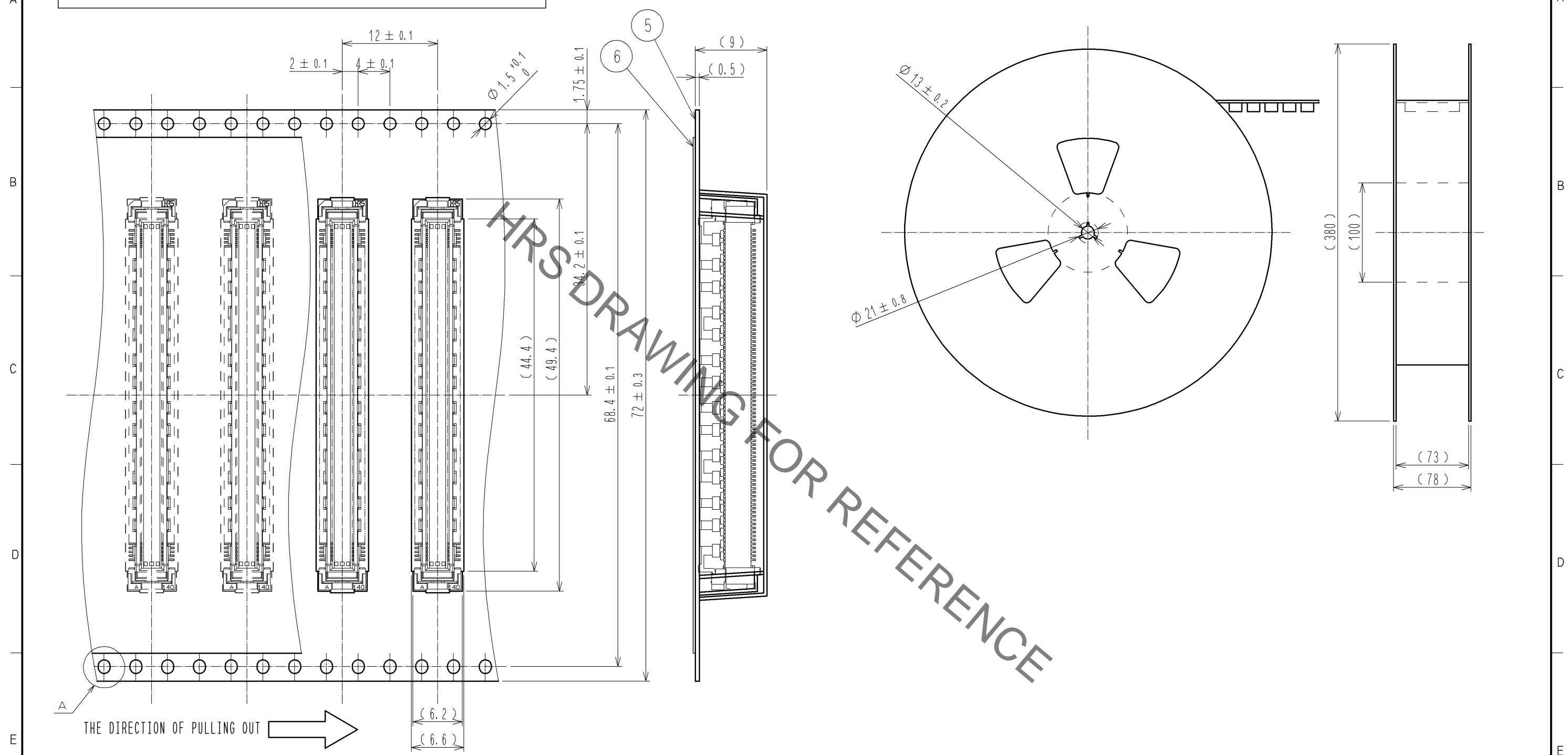

HRS DRAWING FOR REFERENCE

- NOTES 1 1REEL :250 CONNECTORS.
 2 MINIMUM 10 COMPARTMENTS FROM BOTH REEL ENDS REMAIN EMPTY.
 3 THIS PRODUCT HAS NO POLARITY TO TAPE AND REEL PACKAGING.
 4 THE DIMENSIONS IN PARENTHESES ARE FOR REFERENCE.

HRS	DRAWING NO.	EDC3-330883-25
	PART NO.	FX10A-168P-SV4(85)
	CODE NO.	CL570-0306-2-85
		△ 2/2