

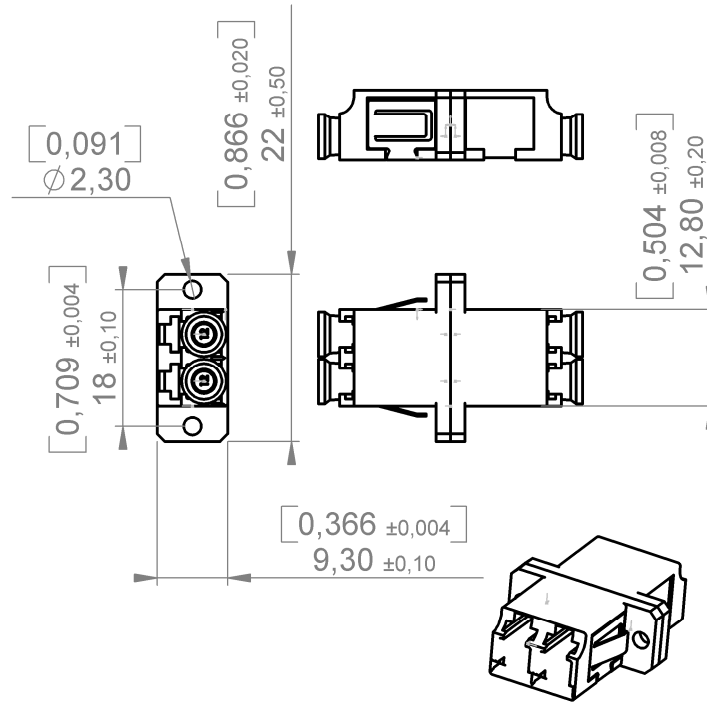

Dimensions : mm / (inches)



GENERAL

TYPE IEC 61754 - 20 (LC)
Receptacle colour : Blue

MOUNTING SC panel cut-out screw in (max. panel thickness 1.7mm)

ALIGNEMENT SLEEVE Zirconia

CHARACTERISTICS (Depending on fibre or cable construction)

MATERIAL Plastic moulded (body UL94 V0 rated)

MECHANICAL Durability : 200 cycles

ENVIRONMENTAL Storage temperature - 40°C / + 85°C
Operating temperature - 25°C / + 70°C

CREATION				RADIALL®	
N°				101, rue P. Hoffmann	
EPF : PEN				93116 ROSNY/BOIS	
F060006080A				FRANCE	
Name : LV				Tel : (33) 0149353535	
Date : June 1 st 06	Mar 9th 12	Panel thickness 1,7 Max instead of 1,6 Max	BD	DT	Fax : (33) 0148546363
Appr : GM	Issue	Revisions	Name	Appr.	