

May.1.2023 Copyright 2023 HIROSE ELECTRIC CO., LTD. All Rights Reserved.
In case of consideration for using Automotive equipment / device which demand high reliability, kindly contact our sales window correspondents.

COUNT	DESCRIPTION OF REVISIONS	B	Y	CHKD	DATE	COUNT	DESCRIPTION OF REVISIONS	B	Y	CHKD	DATE
3	RE-6-0649	J.S.H	J.H.W		16.06.23						

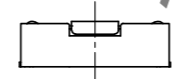

A-A (50:1)

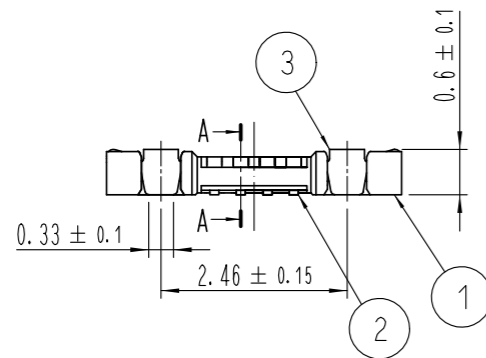
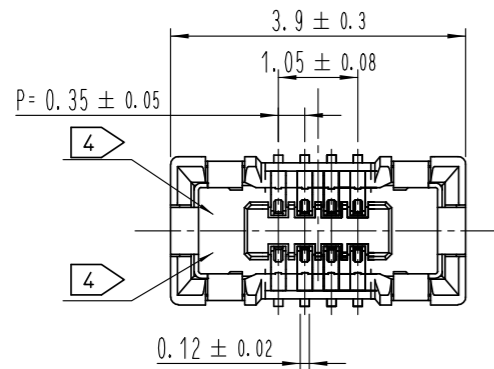
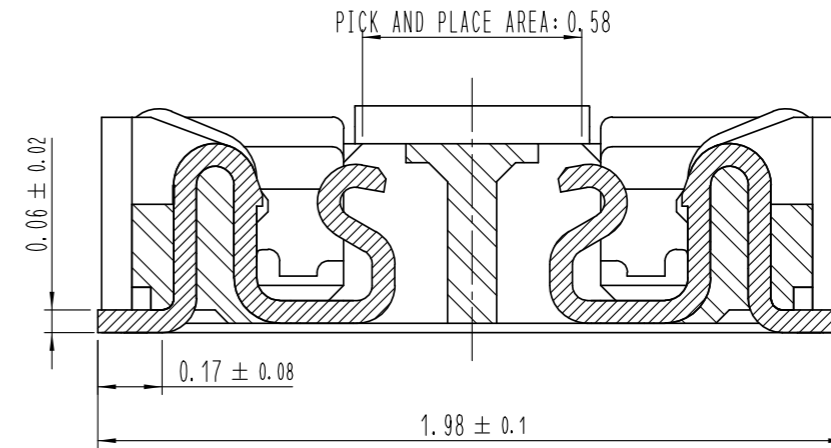

ENGAGEMENT FIGURE (50:1)

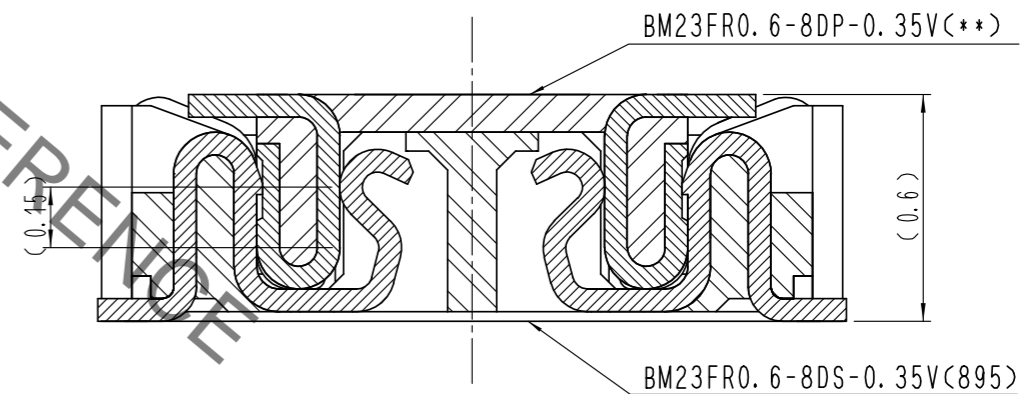

- NOTE
- 1 . ALL LEAD CO-PLANARITY SHALL BE 0.08mm MAX.
 - 2 . CONTACT PLATING SPECIFICATIONS.
CONTACT AREA : GOLD 0.05 μm MIN.
SMT LEAD : GOLD 0.05 μm MIN.
UNDERPLATING : NICKEL 1 μm MIN.
(SURFACE : SEALING)
 - 3 . MATAL FITTING PLATING SPECIFICATIONS.
SMT LEAD : GOLD 0.05 μm MIN.
UNDERPLATING : NICKEL 1 μm MIN.
(SURFACE : SEALING)
 - 4 . HRS MARK AND CAV NO. ARE INDICATED IN APPROX POSITION SHOWN.

4	PS	CLEAR (EMBOSSD CARRIER TAPE)			
3	PHOSPHOR BRONZE	3	7	PS	CLEAR (REINFORCEMENT COLLAR)
2	PHOSPHOR BRONZE	2	6	PS	BLACK (PLASTIC REEL)
1	LCP	UL94 V-0, BLACK	5	POLYESTER	CLEAR (COVER TAPE)
NO.	MATERIAL	FINISH, REMARKS	NO.	MATERIAL	FINISH, REMARKS
REMARKS			DRAWN	DESIGNED	CHECKED
			J. S. PARK	J. S. PARK	H. W. JO
			17.08.09	17.08.09	17.08.09
			APPROVED	RELEASED	
			T. S. KANG		17.08.09
CODE NO. (OLD)	DRAWING NO.	EDC3-632161	PART NO.	BM23FR0.6-8DS-0.35V(895)	
SCALE	10:1		CODE NO	CL 6644-0075-3-895	
UNITS	mm				1/3
HRS HIROSE KOREA CO., LTD.					

HRS DRAWING FOR REFERENCE ONLY

May.1.2023 Copyright 2023 HIROSE ELECTRIC CO., LTD. All Rights Reserved.
In case of consideration for using Automotive equipment / device which demand high reliability, kindly contact our sales window correspondents.

6 RECOMMENDED PCB LAYOUT

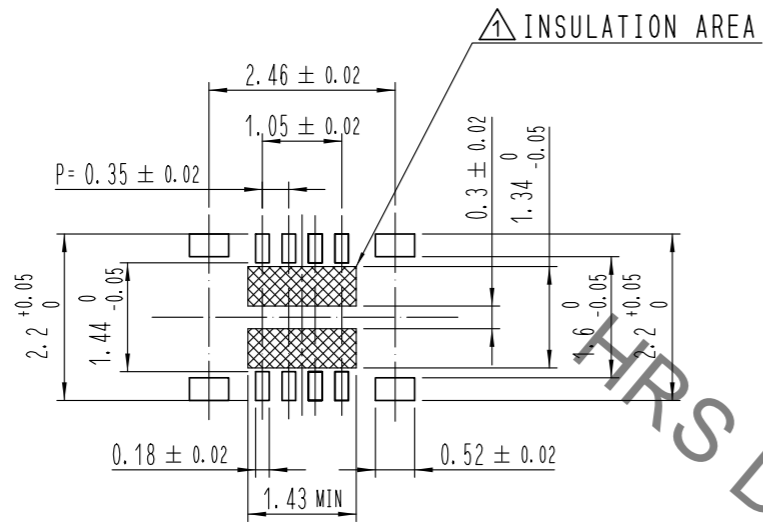

RECOMMENDED METAL MASK DIMENSIONS
MATAL MASK THICKNESS : 100 μm

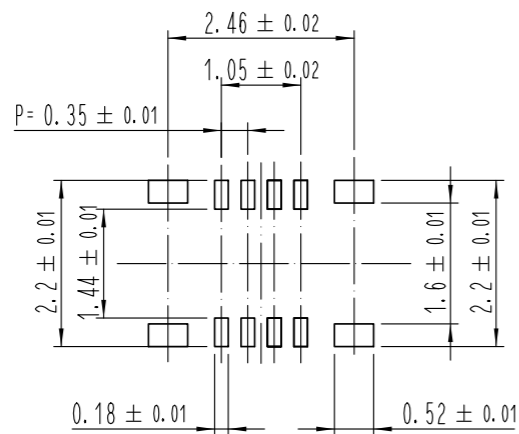

5 RECOMMENDED REFLOW TEMPERATURE PROFILE USING LEAD-FREE SOLDER PASTE.

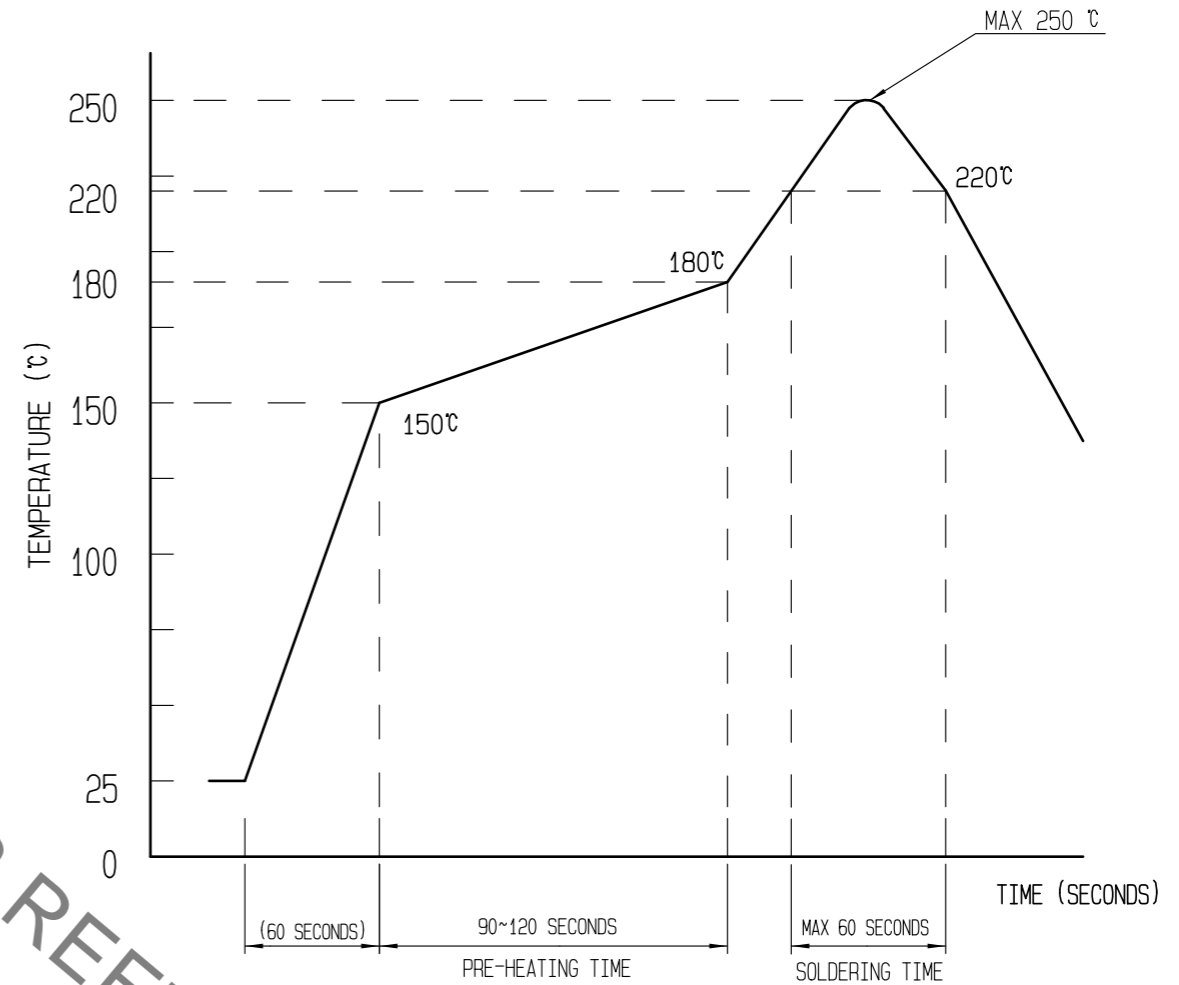

REFLOW METHOD: N₂ REFLOW
 NUMBER OF REFLOW CYCLES: 2 CYCLES MAX.
 1) REFLOW TIME
 DURATION ABOVE 220°C, 60 SEC MAX.
 (PEAK TEMPERATURE: 250°C MAX)
 2) PRE-HEAT TIME
 PRE-HEAT TEMPERATURE(MIN): 150°C
 PRE-HEAT TEMPERATURE(MAX): 180°C
 PRE-HEAT TIME: 90-120 SEC.

- 5 THIS TEMPERATURE PROFILE IS PER THE CONDITIONS SHOWN ABOVE. ADDITIONAL FACTORS, SUCH AS SOLDER PASTE TYPE, PCB SIZE AND OTHER MOUNTED COMPONENTS COULD AFFECT THE PROFILE. THEREFORE, A THOROUGH EVALUATION OF MOUNTING CONDITION IS REQUIRED PRIOR TO PRODUCTION. TEMPERATURE IS MEASURED AT CONTACT LEAD.
- 6 PLEASE CONTACT US IN CASE YOU WILL MAKE DIFFERENT SETTINGS FROM OUR RECOMMENDATION.

	DRAWING NO.	EDC3-632161	PART NO.	BM23FR0.6-8DS-0.35V(895)
	SCALE	10:1	CODE NO	CL 6644-0075-3-895
UNITS	mm	HRS HIROSE KOREA CO., LTD.		2/3

May.1.2023 Copyright 2023 HIROSE ELECTRIC CO., LTD. All Rights Reserved.
In case of consideration for using Automotive equipment / device which demand high reliability, kindly contact our sales window correspondents.

STYLE AND DIMENTION OF REEL (FREE)

EMBOSSED CARRIER TAPE PACKAGING (5:1)

C-C (5:1)

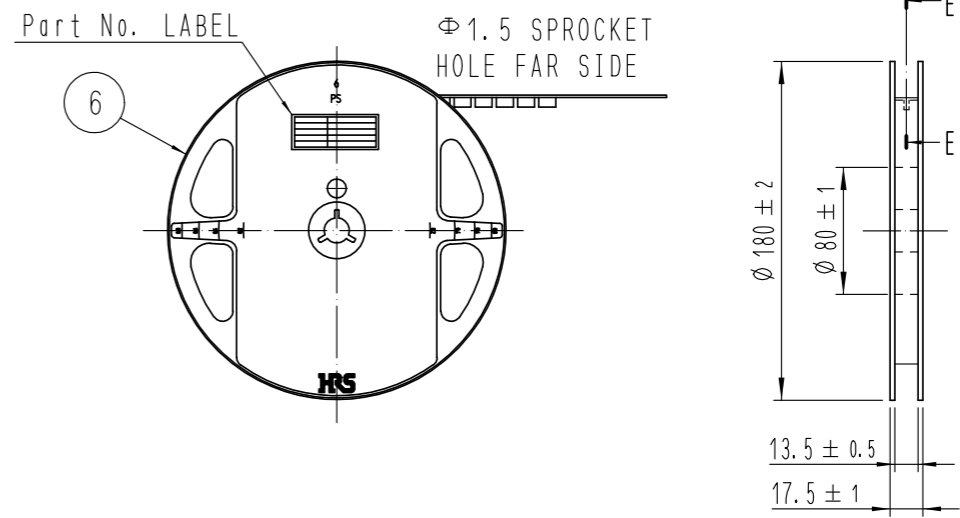
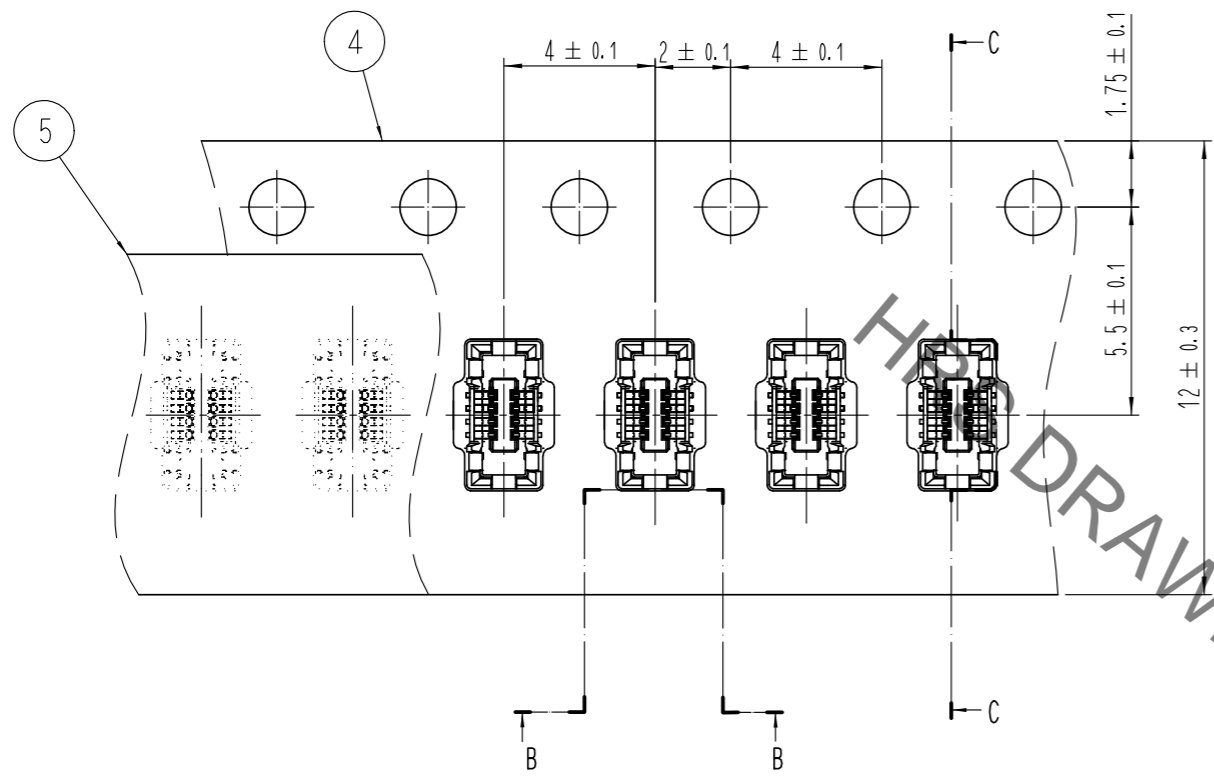

E-E (FREE)

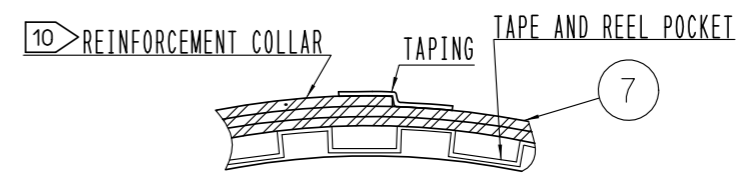

B-B (5:1)

DIRECTION OF UNREELING

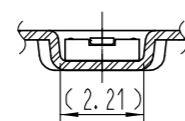

9 TAPING (FREE)

D (10:1)

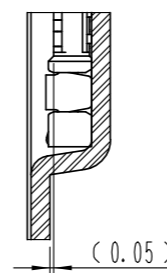

DETAIL OF PART No. LABEL

SUPPLIER	
QUANTITY	
PART NO.	
CODE NO.	
DATE OF MANUFACTURED	
生産月日	年 月 日
図番	** ** *
品名	BM23FR0. 6-8DS-0. 35V(895)
納入数量	1,000個
納入者	HIROSE KOREA

7 . PER REEL 1,000 CONNECTORS.

8 . THE DIMENSIONS IN PARENTHESSES ARE FOR REFERENCE.

9 REFER TO JIS C 0806, IEC-60286-3 (PACKAGING OF COMPONENTS FOR AUTOMATIC HANDLING)

10 AFTER PACKAGING, ROLL 2 METERS OF THE REINFORCEMENT COLLAR TO OUTER CIRCUMFERENCE OF TAPE AND REEL POCKET. AND TAPE DOWN AT THE END THE COLLAR.

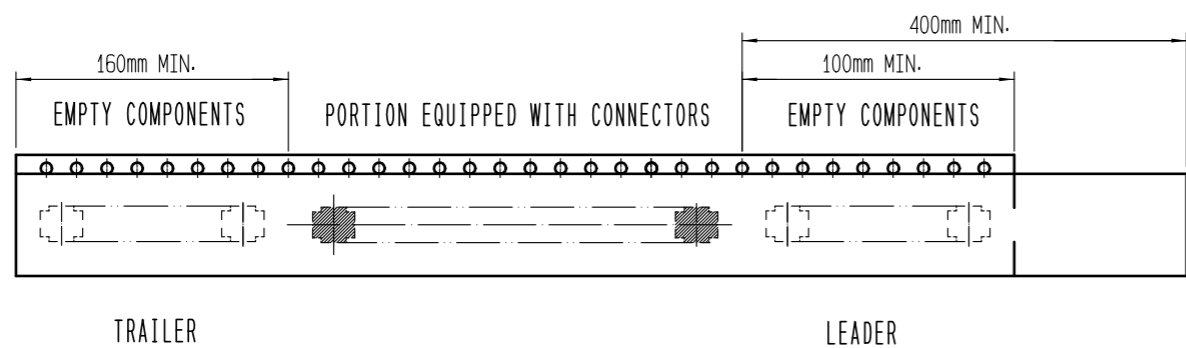

TRAILER

LEADER

DRAWING NO. EDC3-632161	PART NO. BM23FR0. 6-8DS-0. 35V(895)	CODE NO. CL 6644-0075-3-895	3/3
UNITS mm		HRS HIROSE KOREA CO., LTD.	