

May.1.2023 Copyright 2023 HIROSE ELECTRIC CO., LTD. All Rights Reserved.
In case of consideration for using Automotive equipment / device which demand high reliability, kindly contact our sales window correspondents.

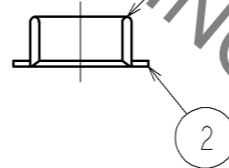

A-A (50:1)

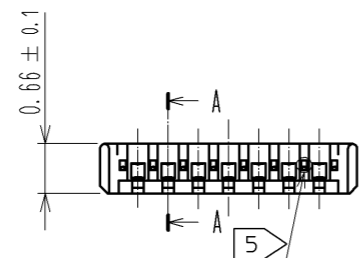
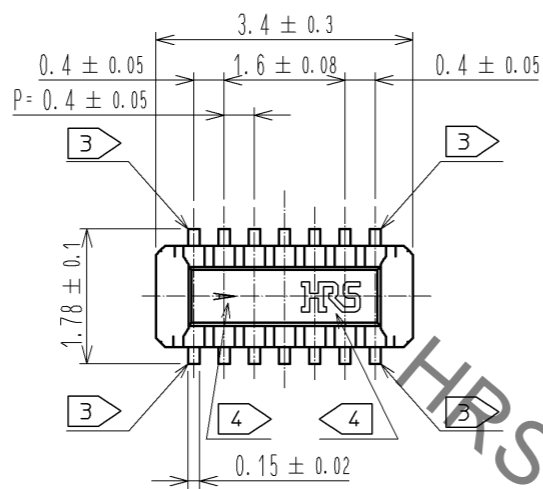
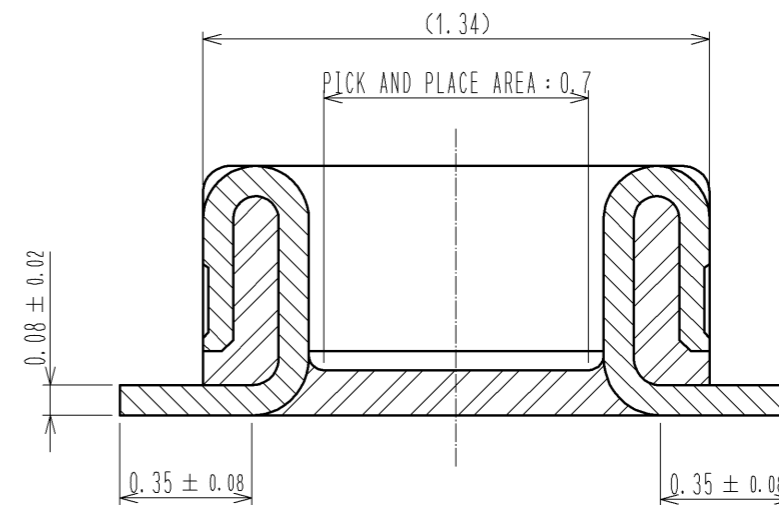

ENGAGEMENT FIGURE (50:1)

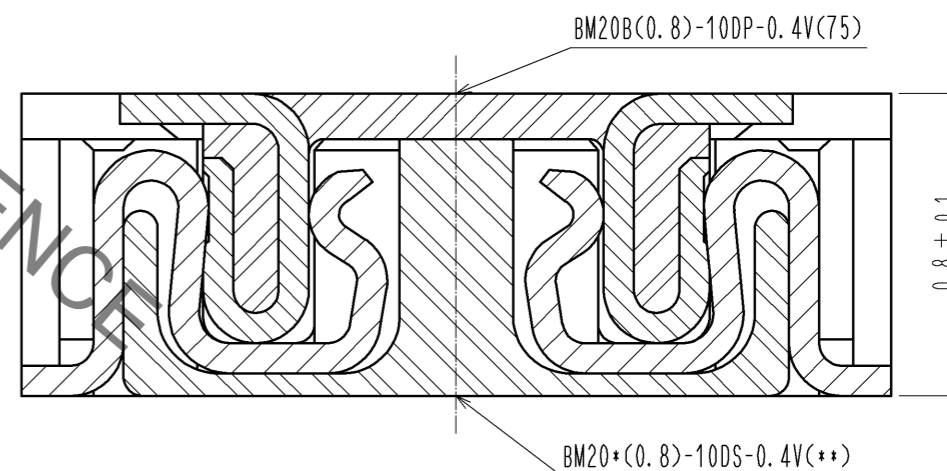

NOTE 1. ALL LEAD CO-PLANARITY SHALL BE 0.08mm MAX

- 2. CONTACT PLATING SPECIFICATIONS
CONTACT AREA : GOLD 0.1 μm MIN
SMT LEAD : GOLD 0.05 μm MIN
UNDER PLATING : NICKEL 1 μm MIN
(SURFACE : SEALING)
- 3. EACH CONTACTS AT 4 CORNERS ARE PROVIDED FOR METAL FITTINGS.
- 4. HRS MARK AND CAV No. ARE INDICATED IN APPROX POSITION SHOWN.
- 5. A PART OF THE WALL COULD BE NOTCHED.

3	PS	CLEAR (EMBOSSED CARRIER TAPE)	6	PS	CLEAR (REINFORCEMENT COLLAR)			
2	PHOSPHOR BRONZE	2	5	PS	BLACK (PLASTIC REEL)			
1	LCP	UL94 V-0, BLACK	4	POLYESTER	CLEAR (COVER TAPE)			
NO.	MATERIAL	FINISH . REMARKS	NO.	MATERIAL	FINISH . REMARKS			
UNITS	⊙	SCALE	COUNT	DESCRIPTION OF REVISIONS		DESIGNED	CHECKED	DATE
mm		10 : 1	△					
HRS HIROSE ELECTRIC CO., LTD.		APPROVED : KH. IKEDA	13.11.12	DRAWING NO. EDC4-332307-03				
		CHECKED : TS. MIYAZAKI	13.11.12	PART NO. BM20B(0.8)-10DP-0.4V(75)				
		DESIGNED : YK. SATAKE	13.11.12	CODE NO. CL684-9001-5-75				
		DRAWN : KR. AJITO	13.11.12					

May.1.2023 Copyright 2023 HIROSE ELECTRIC CO., LTD. All Rights Reserved.
In case of consideration for using Automotive equipment / device which demand high reliability, kindly contact our sales window correspondents.

◆ RECOMMENDED PCB LAYOUT

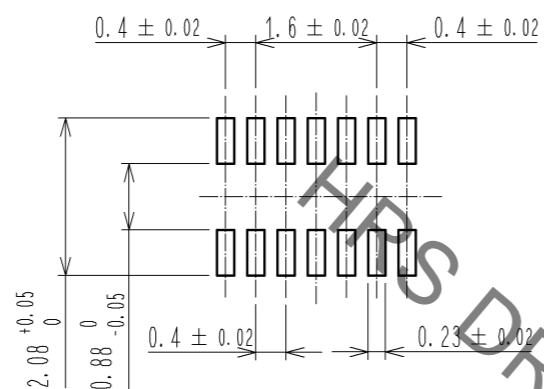

◆ RECOMMENDED METAL MASK DIMENSIONS

METAL MASK THICKNESS : 100 μm

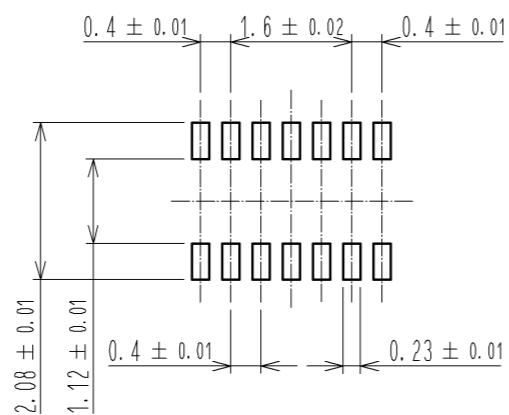

6 RECOMMENDED REFLOW TEMPERATURE PROFILE USING LEAD-FREE SOLDER PASTE.

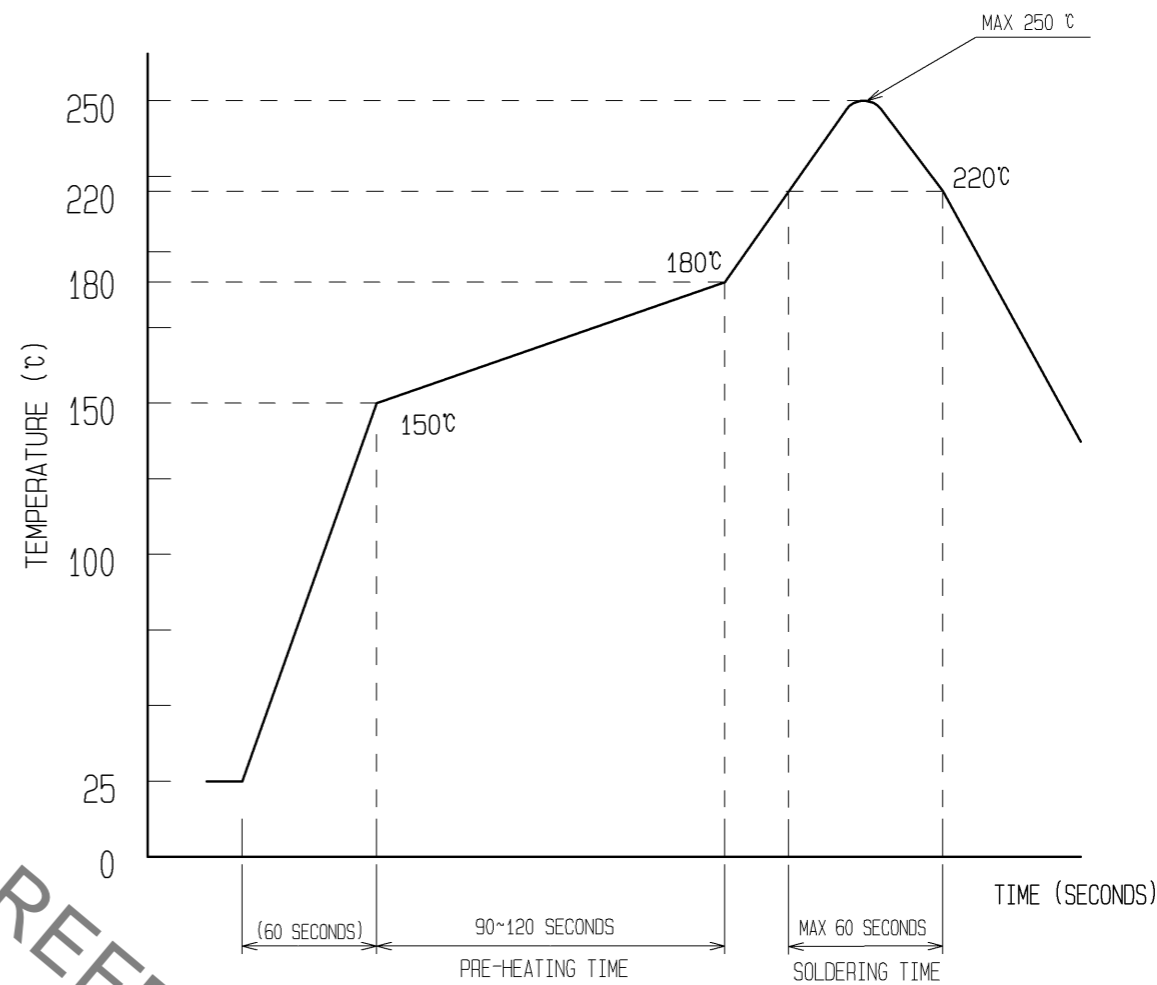

REFLOW METHOD: IR REFLOW
 NUMBER OF REFLOW CYCLES: 2 CYCLES MAX.
 1) REFLOW TIME
 DURATION ABOVE 220°C: 60 SEC MAX.
 (PEAK TEMPERATURE: 250°C MAX)
 2) PRE-HEAT TIME
 PRE-HEAT TEMPERATURE(MIN): 150°C
 PRE-HEAT TEMPERATURE(MAX): 180°C
 PRE-HEAT TIME: 90-120 SEC.

6 THIS TEMPERATURE PROFILE IS PER THE CONDITIONS SHOWN ABOVE. ADDITIONAL FACTORS, SUCH AS SOLDER PASTE TYPE, PCB SIZE AND OTHER MOUNTED COMPONENTS COULD AFFECT THE PROFILE. THEREFORE, A THOROUGH EVALUATION OF MOUNTING COONDITION IS REQUIRED PRIOR TO PRODUCTION. TEPERATURE IS MEASURED AT CONTACT LEAD.

HRS	DRAWING NO.	EDC4-332307-03
	PART NO.	BM20B(0.8)-10DP-0.4V(75)
	CODE NO.	CL684-9001-5-75

May.1.2023 Copyright 2023 HIROSE ELECTRIC CO., LTD. All Rights Reserved.
 In case of consideration for using Automotive equipment / device which demand high reliability, kindly contact our sales window correspondents.

EMBOSED CARRIER TAPE PACKAGING (5:1)

STYLE AND DIMENTION OF REEL (FREE)

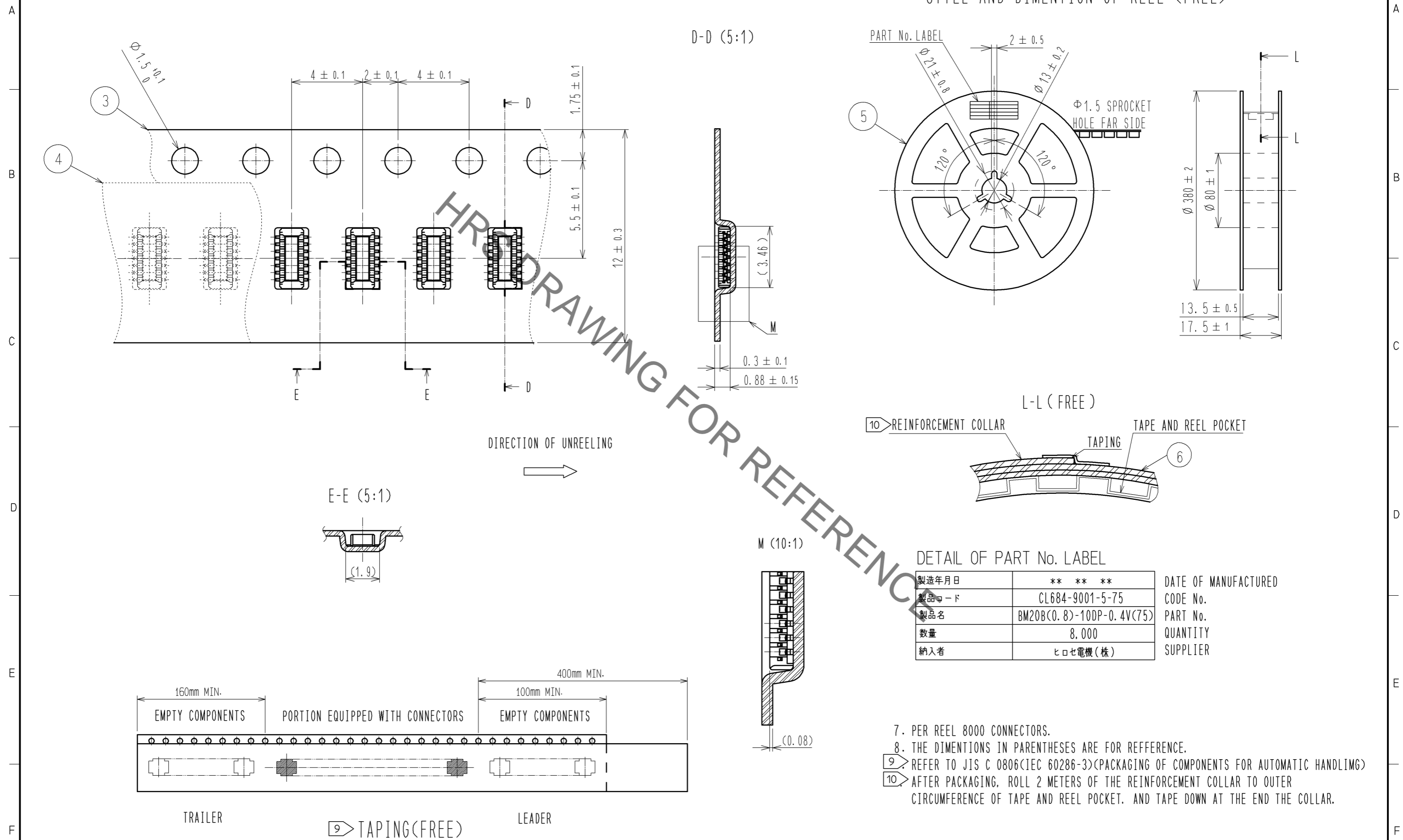

製造年月日	** ** *	DATE OF MANUFACTURED
製品コード	CL684-9001-5-75	CODE No.
製品名	BM20B(0.8)-10DP-0.4V(75)	PART No.
数量	8,000	QUANTITY
納入者	ヒロセ電機(株)	SUPPLIER

- 7. PER REEL 8000 CONNECTORS.
- 8. THE DIMENTION IN PARENTHES ARE FOR REFERENCE.
- 9. REFER TO JIS C 0806(IEC 60286-3)(PACKAGING OF COMPONENTS FOR AUTOMATIC HANDLING)
- 10. AFTER PACKAGING, ROLL 2 METERS OF THE REINFORCEMENT COLLAR TO OUTER CIRCUMFERENCE OF TAPE AND REEL POCKET, AND TAPE DOWN AT THE END THE COLLAR.

HRS	DRAWING NO.	EDC4-332307-03
	PART NO.	BM20B(0.8)-10DP-0.4V(75)
	CODE NO.	CL684-9001-5-75
		△ 3/3