

May.1.2023 Copyright 2023 HIROSE ELECTRIC CO., LTD. All Rights Reserved.
 In case of consideration for using Automotive equipment / device which demand high reliability, kindly contact our sales window correspondents.

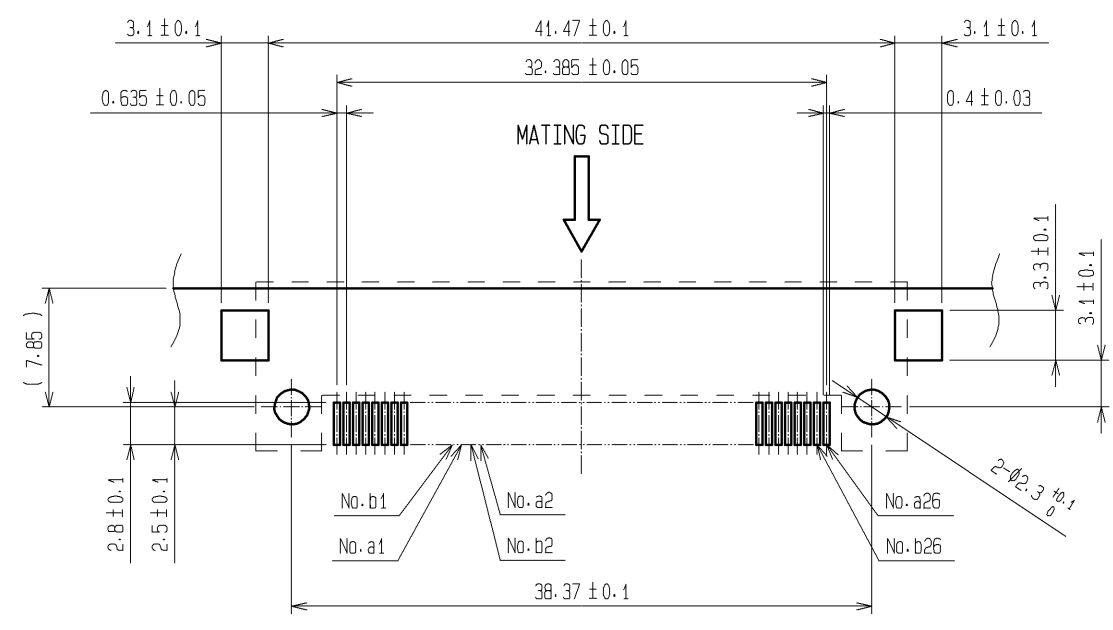

RECOMMENDED P.C.B. LAND PATTERN
 MOUNT SIDE (THICKNESS OF APPLICABLE BOARD: $t=1.6 \pm 0.1$)
 (RECOMMENDED METAL MASK THICKNESS: 0.15mm)

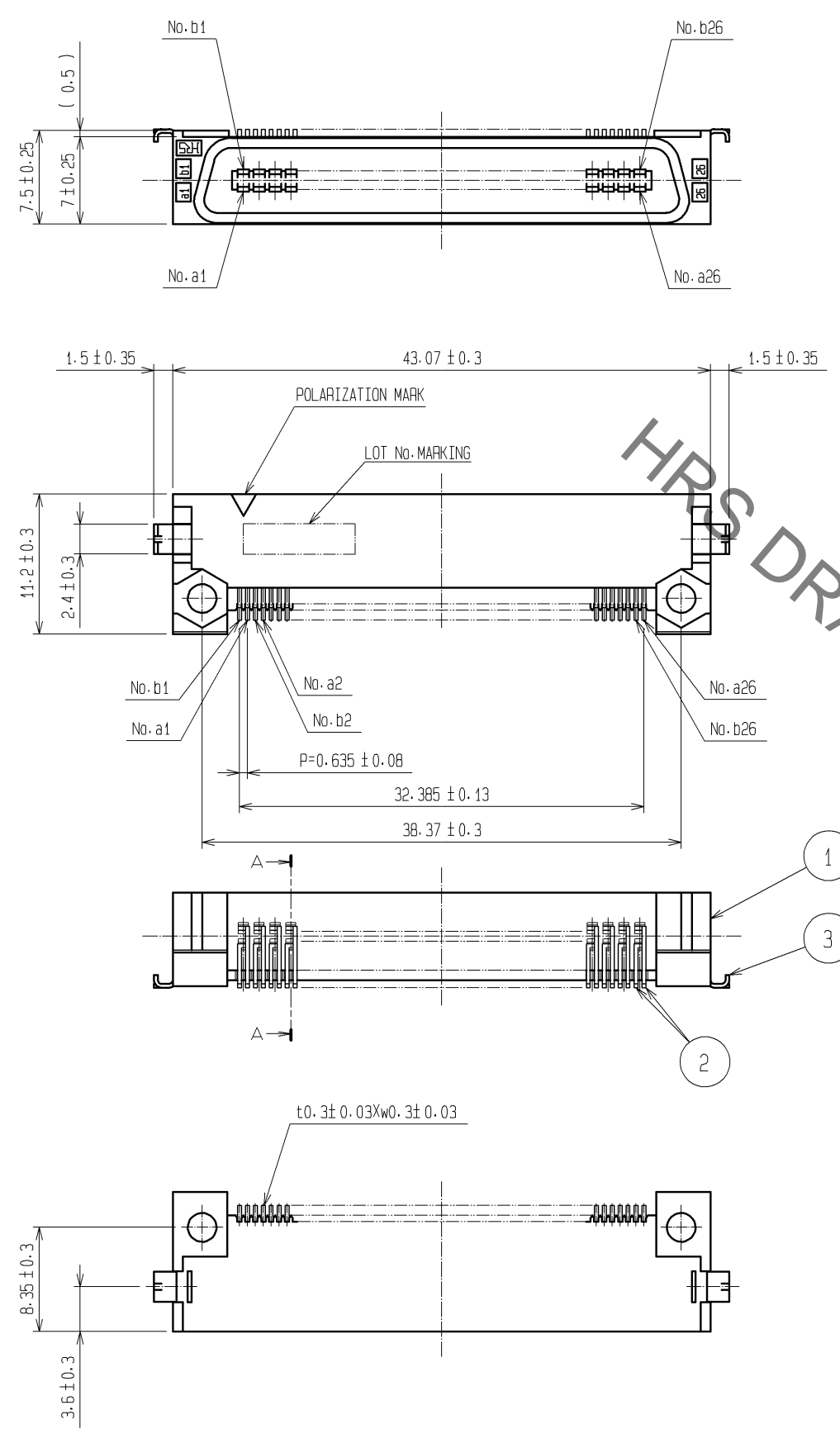
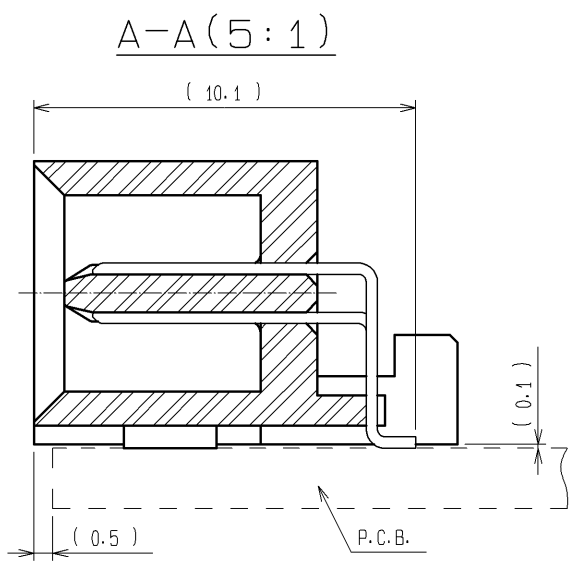

NOTE 1. LEAD CO-PLANARITY SHALL BE 0.1mm MAX.
 2. THE DIMENSIONS IN PARENTHESES ARE FOR REFERENCE.

3	BRASS	TIN-PLATING	2	BRASS	CONTACT AREA : GOLD 0.2μm min.
1	POLYPHENYLENE SULFIDE	LIGHT BROWN (UL94V-0)			LEAD AREA : TIN-PLATING 2μm min.
					UNDER PLATING : NICKEL 1μm min.
NO.	MATERIAL	FINISH . REMARKS	NO.	MATERIAL	FINISH . REMARKS
UNITS mm		SCALE 2 : 1	COUNT 	DESCRIPTION OF REVISIONS	DESIGNED
HRS HIROSE ELECTRIC CO., LTD.		APPROVED : HS. OKAWA 09.04.02		DRAWING NO. EDC3-150360-21	CHECKED
		CHECED : HT. YAMAGUCHI 09.04.02		PART NO. FX2A-52P-0.635SH(71)	DATE
		DESIGNED : SY. KAMIGA 09.04.02		CODE NO. CL572-2774-4-71	
		DRAWN : HK. SUNADORI 09.04.02			

HRS DRAWING FOR REFERENCE