

## M12 MAGNETICS X.CODED STRAIGHT POE 10 GB



Image is for illustration purposes only. Please refer to product description.

|                    |   |
|--------------------|---|
| Part number        | 21 03 381 2825  |
| Specification      | M12 MAGNETICS X.CODED STRAIGHT<br>POE 10 GB   |
| HARTING eCatalogue | <a href="https://b2b.harting.com/21033812825">https://b2b.harting.com/21033812825</a> |

### Identification

|                |  |
|----------------|--|
| Category       | Connectors   |
| Series         | Circular connectors M12  |
| Identification | Magnetics<br>PushPull  |
| Element        | PCB adapter  |
| Specification  | with integrated transformer<br>Straight<br>incl. housing<br>Power over Ethernet (PoE+)<br>for front mounting |

### Version

|                    |                                    |
|--------------------|------------------------------------|
| Termination method | Reflow soldering termination (SMT) |
| Gender             | Female                             |
| Shielding          | Shielded                           |
| Number of contacts | 8                                  |
| Coding             | X-coding                           |
| Locking type       | Screw locking<br>PushPull          |

### Technical characteristics

|                       |        |
|-----------------------|--------|
| Rated current         | 0.8 A  |
| Rated voltage         | 57 V   |
| Rated impulse voltage | 1.5 kV |
| Pollution degree      | 3      |



Pushing Performance  
 Since 1945

## Technical characteristics

|  |  |
|--|--|
| Data rate                              | 10 Mbit/s  |
|  | 100 Mbit/s   |
|  | 1 Gbit/s   |
|  | 2.5 Gbit/s   |
|  | 5 Gbit/s   |
|  | 10 Gbit/s  |
| Insulation resistance                  | $>10^8 \Omega$                                     |
| Contact resistance                     | $\leq 10 \text{ m}\Omega$                          |
| Tightening torque                      | 2 Nm Lock nut                                      |
| Limiting temperature                   | -40 ... +85 °C (during reflow soldering max. +245) |
| Insertion force                        | 30 N   |
| Withdrawal force                       | 30 N   |
| Mating cycles                          | $\geq 100$   |
| Degree of protection acc. to IEC 60529 | IP65 / IP67 mated condition                        |
| Isolation group                        | IIIa ( $175 \leq \text{CTI} < 400$ )               |
| Process Sensitivity Level (PSL)        | R7 acc. to ECA/IPC/JEDEC J-STD-075                 |

## Material properties

|   |  |
|---|--|
| Material (insert)                         | Liquid crystal polymer (LCP)                           |
| Colour (insert)                           | Black  |
| Material (contacts)                       | Brass  |
| Surface (contacts)                        | Au over Ni Mating side                                 |
| Material flammability class acc. to UL 94 | V-0  |
| RoHS                                      | compliant with exemption                               |
| RoHS exemptions                           | 6(c): Copper alloy containing up to 4 % lead by weight |
| ELV status                                | compliant with exemption                               |
| China RoHS                                | 50   |
| REACH Annex XVII substances               | Not contained  |
| REACH ANNEX XIV substances                | Not contained  |
| REACH SVHC substances                     | Yes  |
| REACH SVHC substances                     | Lead   |
| ECHA SCIP number                          | 0d7d3693-d625-47ab-934a-d241bf72c86e                   |
| California Proposition 65 substances      | Yes  |
| California Proposition 65 substances      | Lead   |
|   | Nickel   |
|   | Naphthalene  |

## Material properties

|                                     |                      |
|-------------------------------------|----------------------|
| Fire protection on railway vehicles | EN 45545-2 (2020-08) |
| Requirement set with Hazard Levels  | R26                  |

## Specifications and approvals

|                |                 |
|----------------|-----------------|
| Specifications | IEC 61076-2-109 |
|----------------|-----------------|

## Commercial data

|                                |  |
|--------------------------------|--|
| Packaging size                 | 1  |
| Net weight                     | 23 g                                     |
| Country of origin              | China                                    |
| European customs tariff number | 85366990                                 |
| GTIN                           | 5713140228931                            |
| eCl@ss                         | 27460201 PCB connector (board connector) |

## Panel cut out

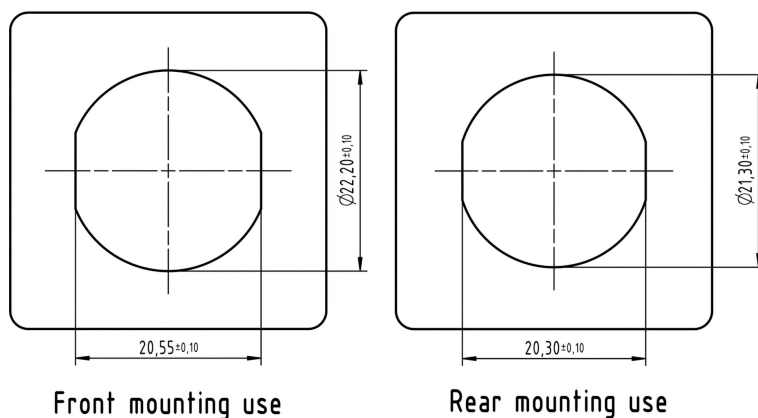

General information

Schematic

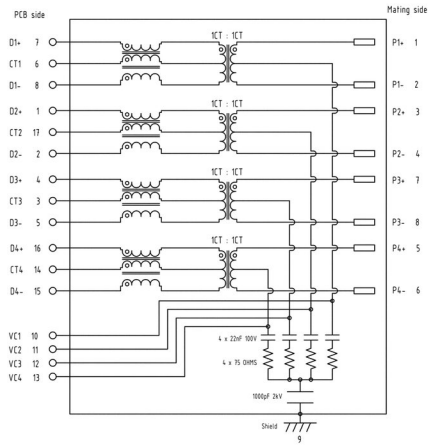

Recommended PCB layout

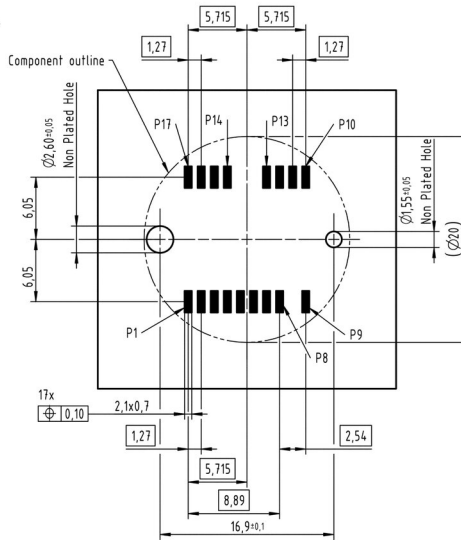

Electrical Characteristics @+25°C unless otherwise noted  
 Meets IEEE802.3 specification  
 RoHS compliant

| Parameter                          | Specification/ Limit Values                        |
|------------------------------------|--|
| Operating Temperature              | -40°C - +85°C                                      |
| Turn Ratio (+/- 2%)                | 1CT : 1CT  |
| Current Capacity Pins 1-8/ VC1-VC4 | 750mA  |
| OCV                                | min 120µH @ 100kHz, 100mV with 18mA bias current   |
| Isolation (Input- Output)          | 2.25kV VDC, for 60sec. min<br>0.1MHz < f ≤ 500 MHz |
| Insertion Loss                     | 3.1 db   |
| Return Loss                        | 5 db   |
| Crosstalk                          | 23 db  |
| CMRR                               | 20 db  |
| CDMR                               | 20 db  |

NOTE: 1. f is the frequency in MHz  
 2. The Product has been tested for DC isolation. HARTING assumes no liability or obligation for AC isolation testing.  
 3. Please note that the M12 Magnetics connector generates less high frequency losses (1-3GHz) compared to an RJ45 with magnetics. In combination with Chipsets that require high frequency losses to pass the PSD test, it is recommended to add a Lowpass filtering network to the M12 10G Magnetics PCB-side for 10GBASE-t signalling (see Detail A).

Detail A

