



MADE IN THE USA

Product Description:

- Scrub Brush Dispenser
- Holds one box of scrub brushes
- Keyholes for wall mounting
- Quartz Beige ABS Plastic

Primary Area for Product Usage:

- Surgical/procedure areas
- Any location where scrub brushes are needed

Dispenses:

- Box(es) no larger than 4.83"W x 20.00"H x 5.00"D (13.3 cm x 50.8 cm x 13.3 cm)
- Box(es) no smaller than 4.08"W x 8.00"H x 4.25"D (12.1 cm x 20.3 cm x 12.7 cm)

Package Specifications:

- Package Quantity: 6 per case
- 16"L x 12"W x 12"H (40.6 cm x 30.5 cm x 30.5 cm)
- 5.0 lbs (2.3 kg) - approximated

Product Specifications (overall external dimensions):

- 5.08"W x 9.10"H x 5.33"D (12.9 cm x 23.1 cm x 13.5 cm)
- 0.3 lbs (0.2 kg) - approximated

Mounting Specifications:

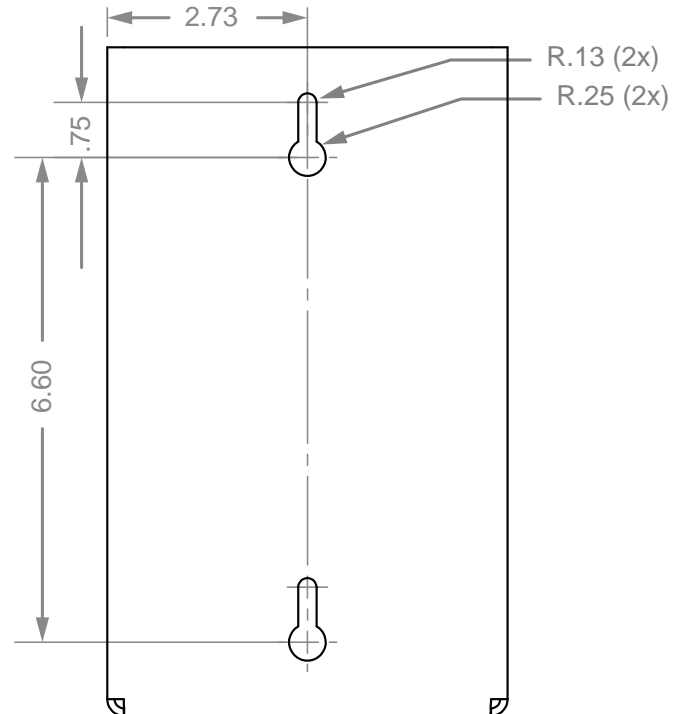

Companion Products (each sold separately):

- FM100-0212: Face Mask Dispenser - Universal Boxed - Earloop
- FM200-0212: Face Mask Dispenser - Universal Boxed - Face Shield
- FM300-0212: Face Mask Dispenser - Universal Boxed - Cone
- PD100-0212: Protection Dispenser - Universal Boxed - Shoe Cover/Cap/Other
- PD200-0212: Protection Dispenser - Universal Boxed - Shoe Cover/Cap/Other - Large
- PD300-0212: Protection Dispenser - Universal Boxed - Shoe Cover/Cap/Other



FM200-0212



PD100-0212





Installation

Always mount dispensers securely *prior* to loading with product.

- Wide, open front design allows for most box openings.
- High sides hold tall boxes.

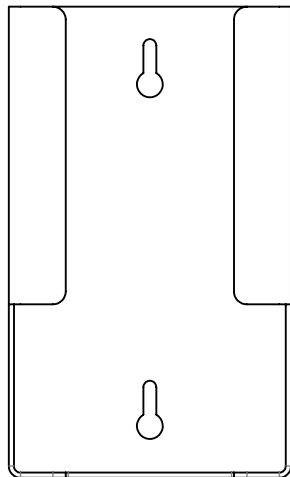

1

- Mount securely to a wall with screws approved and supplied by building maintenance.

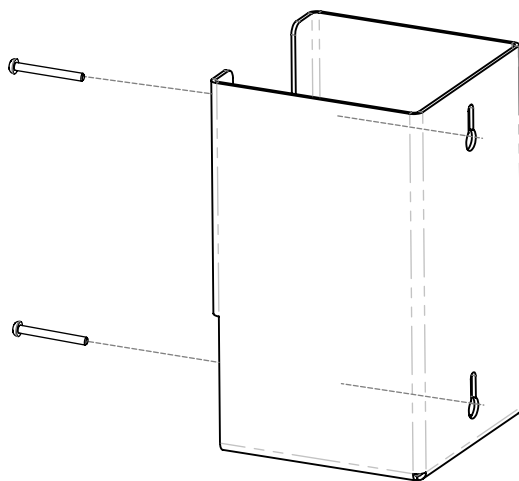

2

Parts included:

- Dispenser

Tools Required:

- No tools required to assemble dispenser

Characteristics & Care

ABS Plastic

Material Characteristics

Designed for Long-Term, Heavy-Duty Applications

The combination of copolymers (Acrylonitrile, Butadiene, and Styrene) gives ABS an excellent combination of strength, rigidity, and toughness.

ABS is chemical, stress-crack resistant, dimensionally stable, and will hold up to long-term use. It possesses high strength and performance characteristics at a reasonable cost.

Care and Cleaning

Use mild soap and water to clean. Petroleum-based oils, solvents, and paints should not be used.

Standard hospital cleaning supplies are approved for use on our ABS plastic products.