



OVMed[®]-0137 Mini Class Medical Image Signal Processor Module product brief



Wi-Fi Connected Module is Cost-Effective and Compact for Endoscopes and Catheters



available in a lead-free package

OmniVision's OVMed[®]-0137 is an ASIC-based, stand-alone image signal processor (ISP) module with Wi-Fi output. Designed to pair with our high-performance medical image sensors, the OVMed[®]-0137 provides a small and cost-effective option for catheters and single-use and reusable endoscope handles.

The OVMed[®]-0137 module can be quickly and easily integrated into medical imaging systems, allowing customers to fully utilize the many performance and imaging capabilities this compact module has to offer without extending time-to-market.

Find out more at www.ovt.com.



Applications

- Medical Endoscopes and Catheters
- Industrial Video Scopes
- Veterinarian Endoscopes
- Security and Surveillance Monitoring Systems

Product Features

- Integrated design:
 - Sensor
 - Processor bridge
 - ISP
 - Wi-Fi module
- 4-pin or 10-pin mixed-signal interface for OmniVision medical image sensors
- Advanced ISP delivers high-quality image sizes:
 - 400 x 400
 - 200 x 200
- Software tool for customer setting adjustments, easily adjustable system parameters with pre-defined buttons, including brightness, contrast, and saturation
- Supports AEC/AGC/AWB control
- Reconfigurable camera and display / control connected wirelessly
- Market-ready, end-to-end solution
- Supports most wireless platforms:
 - Windows
 - MacOS
 - Android
 - iOS
- Software development kits (SDK) support customers developing their applications
- Supports battery power: 6.5 hours operation per full battery change

OVMed[®]-0137



Ordering Information

- **OH00000-EG02-1A-0137**
OVMed[®]-0137 output board for OVMed[®] ISP (E2)

- Package includes:
- OmniVision camera AA module/daughter board with OV6946 image sensor
 - PCB motherboard with OV6946 interface
 - USB power adapter
 - USB cable with micro USB connector
 - Rechargeable battery
 - CD-ROM containing:
 - Setup program
 - OVMed[®]-WX-Mini User Manual
 - OVMed[®]-WX-Mini Hardware Manual
 - OVMed[®]-WX-Mini SDK Development Guide



Product Specifications

- Board size:
L: 86 mm, W: 20 mm, H: 12 mm
- Standard 5V power supply
- Battery power switch: 1
- Power button: 1
- Input connector: 4-pin OmniVision AA module; 10-pin connector
- Power and charge connector: Micro USB
- Wireless antenna: 1
- Wireless output: IEEE802.11 ac with 5 GHz frequency
- Image output formats: motion JPEG
- Image capture rate: 30 fps

Functional Block Diagram

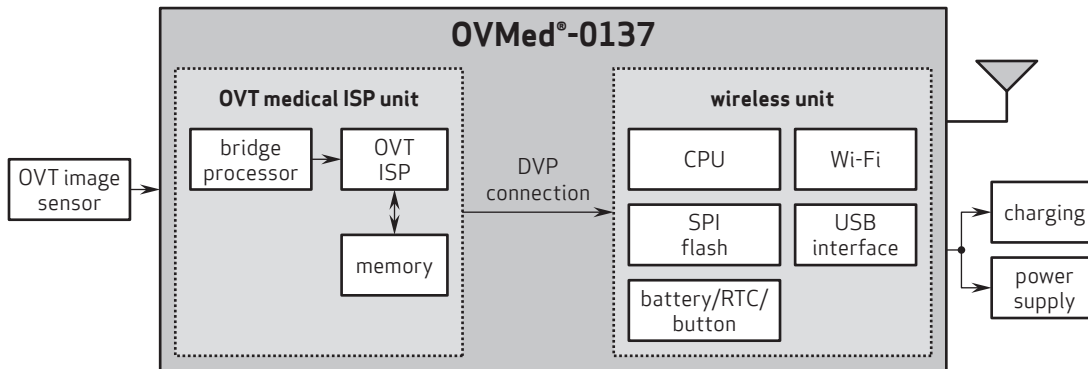

4275 Burton Drive
Santa Clara, CA 95054
USA

Tel: + 1 408 567 3000
Fax: + 1 408 567 3001
www.ovt.com

OmniVision reserves the right to make changes to their products or to discontinue any product or service without further notice. OmniVision, the OmniVision logo and OVMed are registered trademarks of OmniVision Technologies, Inc. All other trademarks are the property of their respective owners.



OmniVision