

**ECN/PCN No.: 4145**

For Manufacturer			
<b>Product Description:</b> PLASTIC SMD MEMS OSCILLATOR	<b>Abracon Part Number / Part Series:</b> EMRB62	<input type="checkbox"/> Documentation only <input type="checkbox"/> ECN <input checked="" type="checkbox"/> EOL	<input checked="" type="checkbox"/> Series <input type="checkbox"/> Part Number
<b>Affected Revision:</b> B	<b>New Revision:</b> EOL	<b>Application:</b>	<input type="checkbox"/> Safety <input checked="" type="checkbox"/> Non-Safety
<b>Prior to Change:</b> Active <a href="https://abracon.com/datasheets/Ecliptek/EMRB62.pdf">https://abracon.com/datasheets/Ecliptek/EMRB62.pdf</a>			
<b>After Change:</b> EOL			
<b>Cause/Reason for Change:</b> Discontinuation of manufacturing capability.			
Change Plan			
<b>Effective Date:</b> 2/7/2022	<b>Additional Remarks:</b> N/A		
<b>Change Declaration:</b> N/A			
<b>Issued Date:</b> 2/7/2022	<b>Issued By:</b> <i>Brooke Cushman Product Engineer</i>	<b>Issued Department:</b> Engineering	
<b>Approval:</b> <i>Thomas Culhane Engineering Director</i>	<b>Approval:</b> <i>Reuben Quintanilla Quality Director</i>	<b>Approval:</b> <i>Ying Huang Purchasing Director</i>	
For Abracon EOL only			
<b>Last Time Buy (if applicable):</b> 5/7/2022	<b>Alternate Part Number / Part Series:</b> none		
<b>Additional Approval:</b>	<b>Additional Approval:</b>	<b>Additional Approval:</b>	
Customer Approval (If Applicable)			
<b>Qualification Status:</b> <input type="checkbox"/> Approved <input type="checkbox"/> Not accepted <i>Note: It is considered approved if there is no feedback from the customer 1 month after ECN/PCN is released.</i>			
<b>Customer Part Number:</b>		<b>Customer Project:</b>	
<b>Company Name:</b>	<b>Company Representative:</b>	<b>Representative Signature:</b>	
<b>Customer Remarks:</b>			

## REGULATORY COMPLIANCE



## ITEM DESCRIPTION

MEMS Clock Oscillators LVCMOS (CMOS) 2.5Vdc 4 Pad 1.2mm x 2.0mm Plastic Surface Mount (SMD)

## ELECTRICAL SPECIFICATIONS

Nominal Frequency	32.768kHz
Frequency Tolerance/Stability	Inclusive of all conditions: Calibration Tolerance at 25°C, Frequency Stability over the Operating Temperature Range, Supply Voltage Change, and Output Load Change ±75ppm Maximum over -10°C to +70°C ±100ppm Maximum over -40°C to +85°C
Frequency Tolerance	Measured at 25°C ±2°C, at Vdd=2.5Vdc, Post Reflow ±20ppm Maximum
Aging at 25°C	±1ppm Maximum First Year
Supply Voltage	2.5Vdc ±10%
Input Current	No Load, Nominal Vdd 1.0µA Typical (at 25°C), 2.2µA Maximum at Frequency Tolerance/Stability of ±100ppm Maximum over -40°C to +85°C 1.0µA Typical (at 25°C), 1.9µA Maximum at Frequency Tolerance/Stability of ±75ppm Maximum over -10°C to +70°C
Output Voltage Logic High (V <sub>OH</sub> )	I <sub>OH</sub> = -10µA 90% of Vdd Minimum
Output Voltage Logic Low (V <sub>OL</sub> )	I <sub>OL</sub> = +10µA 10% of Vdd Maximum
Rise/Fall Time	Measured from 10% to 90% of waveform 100nSec Typical, 200nSec Maximum
Duty Cycle	Measured at 50% of waveform 50 ±2(%)
Load Drive Capability	15pF Maximum
Output Logic Type	CMOS
Period Jitter (RMS)	Measured at 25°C 35nSec Typical
Power Supply Ramp	Measured at 0Vdc to 90% of Vdd 100mSec Maximum
Start Up Time	Measured at Nominal Vdd 180mSec Typical, 500mSec Maximum at Frequency Tolerance/Stability of ±100ppm Maximum over -40°C to +85°C 180mSec Typical, 450mSec Maximum at Frequency Tolerance/Stability of ±75ppm Maximum over -10°C to +70°C
Storage Temperature Range	-55°C to +125°C

## PART NUMBERING GUIDE

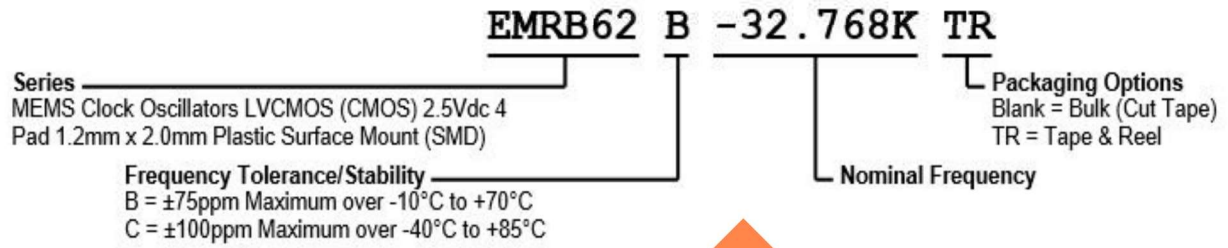

MECHANICAL DIMENSIONS

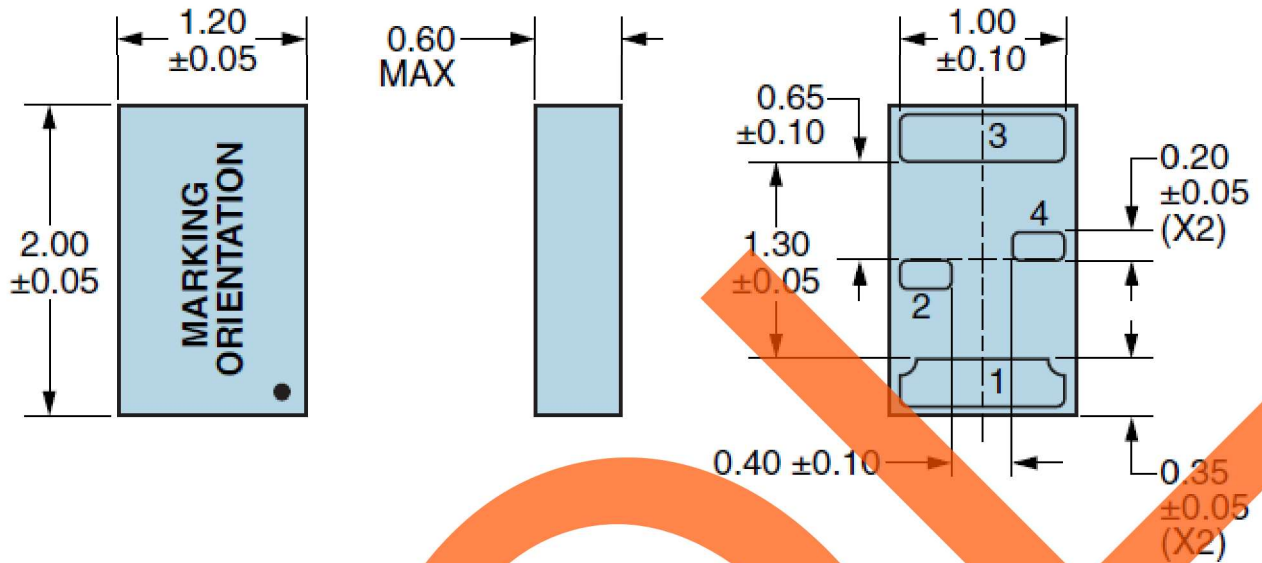

SUGGESTED SOLDER PAD LAYOUT

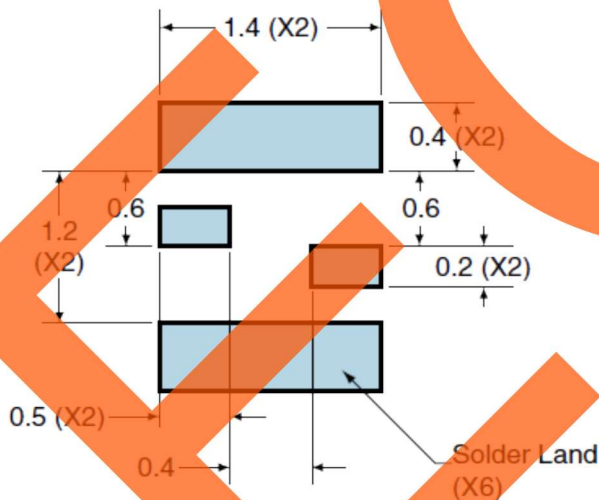

PIN	CONNECTION
1	No Connect
2	Ground
3	Output
4	Supply Voltage

All Tolerances are ±0.1

All Dimensions in Millimeters

### OUTPUT WAVEFORM & TIMING DIAGRAM

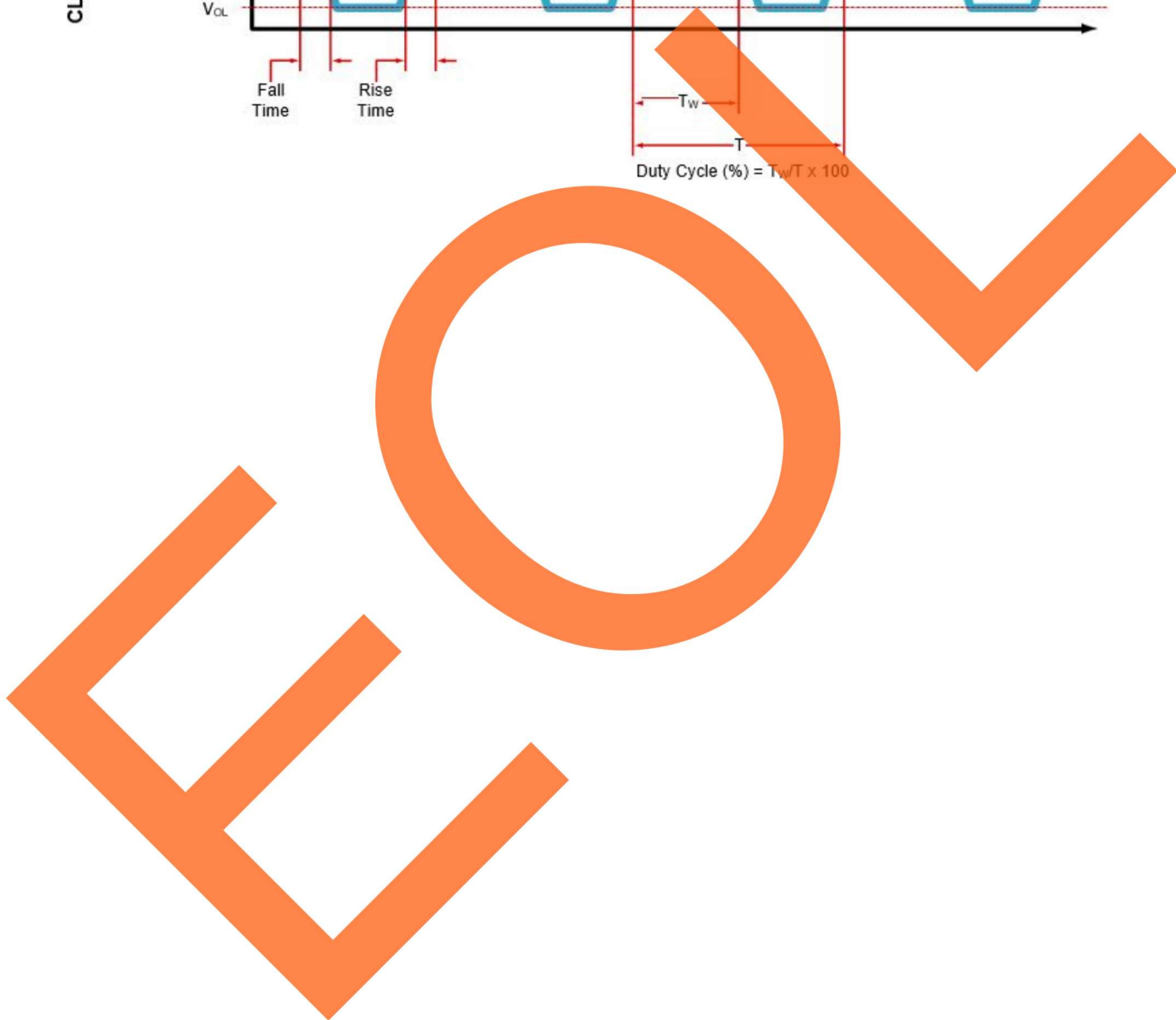
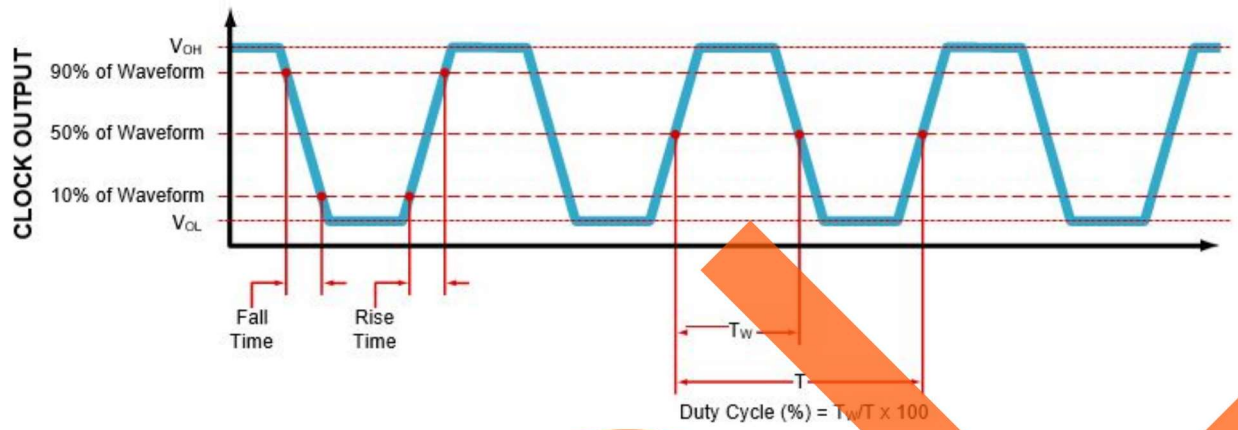

## TEST CIRCUIT FOR CMOS OUTPUT

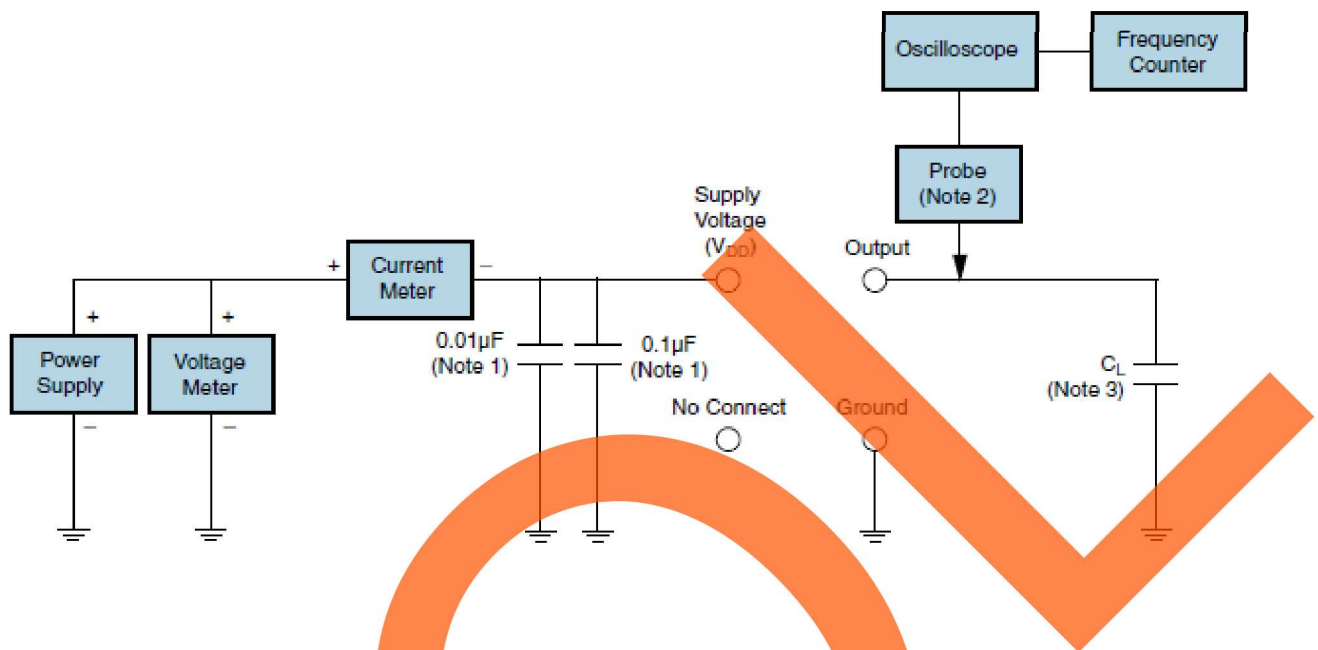

**Note 1:** An external  $0.01\mu\text{F}$  ceramic bypass capacitor in parallel with a  $0.1\mu\text{F}$  high frequency ceramic bypass capacitor close (less than 2mm) to the package ground and supply voltage pin is required.

**Note 2:** A low input capacitance ( $<12\text{pF}$ ), 10X attenuation factor, high impedance ( $>10\text{Mohms}$ ), and high bandwidth ( $>300\text{MHz}$ ) Passive probe is recommended.

**Note 3:** Capacitance value  $C_L$  includes sum of all probe and fixture capacitance. See applicable specification sheet for 'Load Drive Capability'.

**TAPE & REEL DIMENSIONS**

Quantity per Reel: 3000 Units

All Dimensions in Millimeters

Compliant to EIA-481

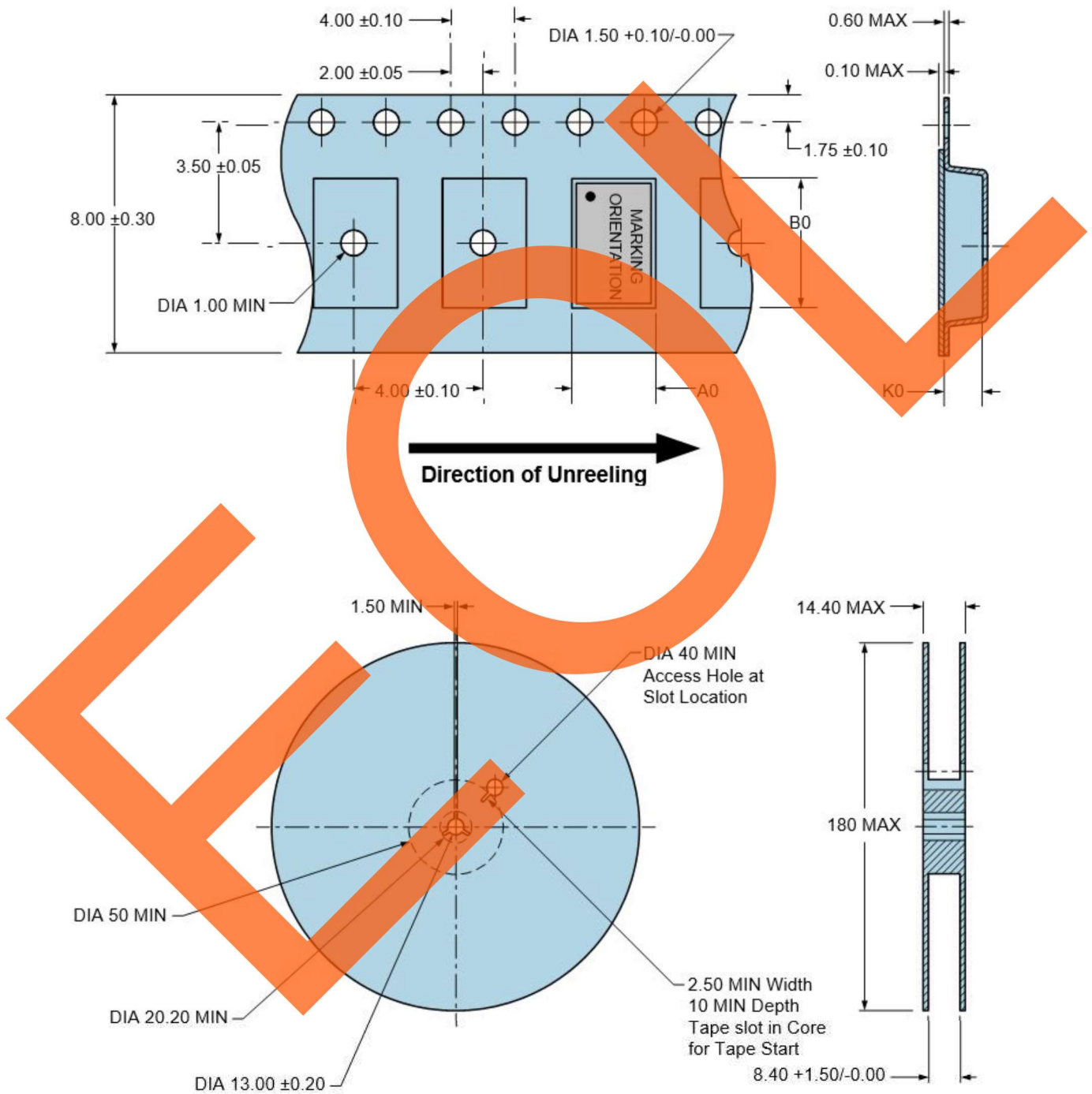

RECOMMENDED SOLDER REFLOW METHOD

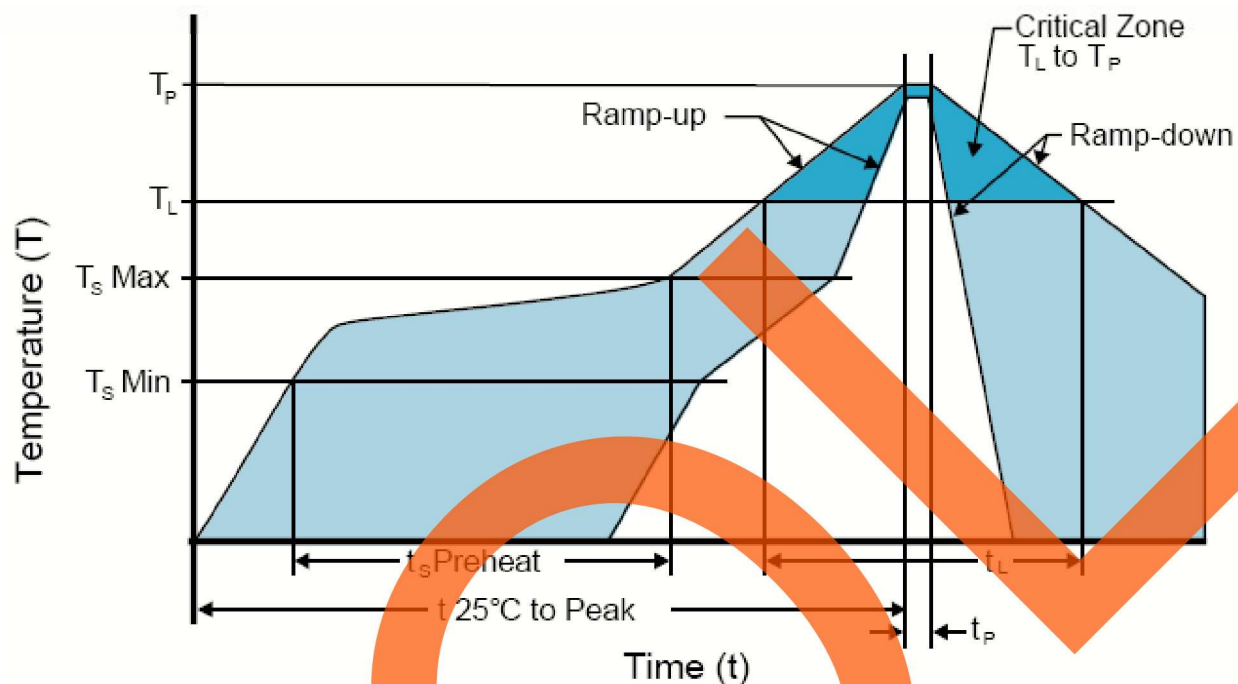

**HIGH TEMPERATURE INFRARED/CONVECTION**

T <sub>S</sub> MAX to T <sub>L</sub> (Ramp-up Rate)	3°C/Second Maximum
<b>Preheat</b>	
- Temperature Minimum (T <sub>S</sub> MIN)	150°C
- Temperature Typical (T <sub>S</sub> TYP)	175°C
- Temperature Maximum (T <sub>S</sub> MAX)	200°C
- Time (t <sub>s</sub> )	60 - 180 Seconds
<b>Ramp-up Rate (T<sub>L</sub> to T<sub>P</sub>)</b>	3°C/Second Maximum
<b>Time Maintained Above:</b>	
- Temperature (T <sub>L</sub> )	217°C
- Time (t <sub>L</sub> )	60 - 150 Seconds
<b>Peak Temperature (T<sub>P</sub>)</b>	260°C Maximum for 10 Seconds Maximum
<b>Target Peak Temperature (T<sub>P</sub> Target)</b>	250°C +0/-5°C
<b>Time within 5°C of actual peak (t<sub>p</sub>)</b>	20 - 40 Seconds
<b>Ramp-down Rate</b>	6°C/Second Maximum
<b>Time 25°C to Peak Temperature (t)</b>	8 Minutes Maximum
<b>Moisture Sensitivity Level</b>	Level 1
<b>Additional Notes</b>	Temperatures shown are applied to body of device.

**High Temperature Manual Soldering**

260°C Maximum for 5 Seconds Maximum, 2 times Maximum. (Temperatures shown are applied to body of device.)



## RECOMMENDED SOLDER REFLOW METHOD

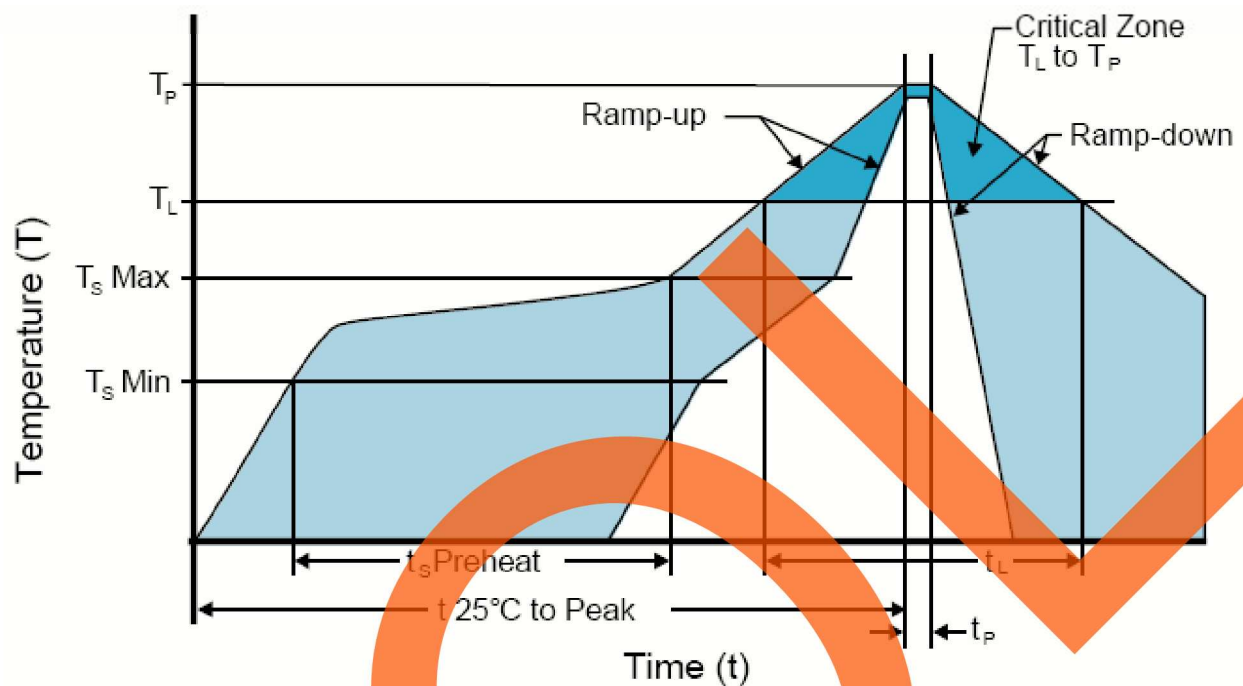

## LOW TEMPERATURE INFRARED/CONVECTION

$T_S$ MAX to $T_L$ (Ramp-up Rate)	5°C/Second Maximum
Preheat	
- Temperature Minimum ( $T_S$ MIN)	N/A
- Temperature Typical ( $T_S$ TYP)	150°C
- Temperature Maximum ( $T_S$ MAX)	N/A
- Time ( $t_s$ )	60 - 120 Seconds
Ramp-up Rate ( $T_L$ to $T_P$ )	5°C/Second Maximum
Time Maintained Above:	
- Temperature ( $T_L$ )	150°C
- Time ( $t_L$ )	200 Seconds Maximum
Peak Temperature ( $T_P$ )	240°C Maximum
Target Peak Temperature ( $T_P$ Target)	240°C Maximum 2 Times / 230°C Maximum 1 Time
Time within 5°C of actual peak ( $t_p$ )	10 Seconds Maximum 2 Times / 80 Seconds Maximum 1 Time
Ramp-down Rate	5°C/Second Maximum
Time 25°C to Peak Temperature (t)	N/A
Moisture Sensitivity Level	Level 1
Additional Notes	Temperatures shown are applied to body of device.

## Low Temperature Manual Soldering

185°C Maximum for 10 Seconds Maximum, 2 times Maximum. (Temperatures shown are applied to body of device.)