

CATALOG NUMBER	MATERIAL NUMBER	CABLE RANGE	LENGTH "M"	LENGTH "B"	LENGTH "C" REF.	DIAMETER "D" REF.	APPROXIMATE BREAK STRENGTH (LBS/N)	UL LISTED	CSA APPROVED
36660	-----	.100-.200 / 2.54-5.08	9.00±0.75 / 228.6±19.1	5.50±0.25 / 139.7±6.4	1.40 / 35.6	.80 / 20.3	1000 / 4448	NO	YES
36661	1300950297	.210-.350 / 5.33-8.89	14.00±0.75 / 355.6±19.1	5.50±0.25 / 139.7±6.4	1.40 / 35.6	.80 / 20.3	1500 / 6672		
36662	1300950298	.320-.480 / 8.13-12.19	18.00±1.00 / 457.2±25.4	5.75±0.25 / 146.1±6.4	1.40 / 35.6	.90 / 22.9	2200 / 9786		
36663	1300950299	.420-.610 / 10.67-15.49	21.00±1.25 / 533.4±31.8	5.75±0.25 / 146.1±6.4	1.40 / 35.6	.90 / 22.9	2800 / 12455		
36664	1300950300	.530-.740 / 13.46-18.80	24.00±1.25 / 609.6±31.8	6.25±0.25 / 158.8±6.4	1.49 / 37.8	1.15 / 29.2	3300 / 14679		
36665	1300950301	.640-.875 / 16.26-22.23	27.00±1.25 / 685.8±31.8	6.25±0.25 / 158.8±6.4	1.49 / 37.8	1.15 / 29.2	4700 / 20907		

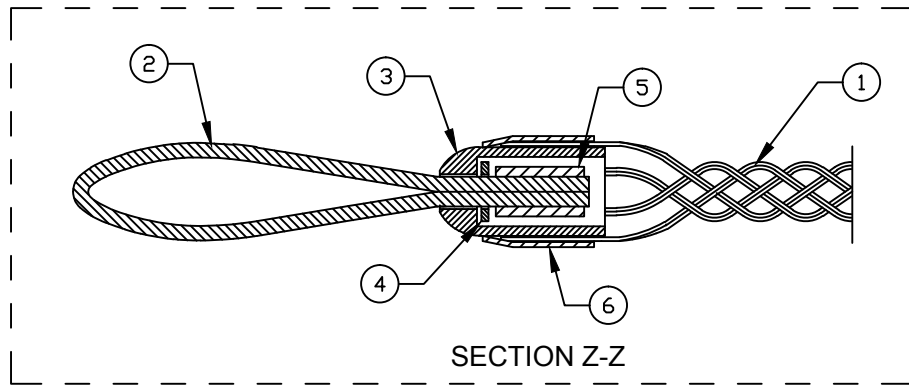
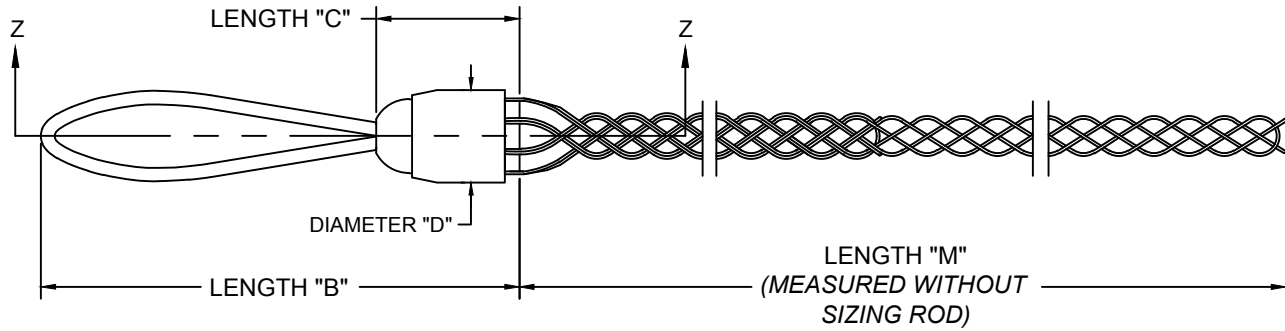

ITEM	DESCRIPTION	MATERIAL
1	WIRE MESH	GALVANIZED STEEL
2	BALE WIRE	GALVANIZED STEEL
3	BALE NOSE	STEEL
4	WASHER	NYLATRON
5	SWAGING FERRULE	STEEL
6	OUTER RING	STEEL

RELEASE SALES DWG EC NO: IPC2015-1537 DRWN: HRUIZ01 2015/03/19 CHKD: HKNEELAN 2015/03/19 APPR: JFMURPHY 2015/06/12	DESCRIPTION	QUALITY SYMBOLS ▽=0 ▽C=0
A	REV	

GENERAL TOLERANCES (UNLESS SPECIFIED)	
	mm INCH
4 PLACES	±--- ±---
3 PLACES	±--- ±.005
2 PLACES	±.13 ±.010
1 PLACE	±.25 ±.010
ANGULAR ±1/2°	
DRAFT WHERE APPLICABLE MUST REMAIN WITHIN DIMENSIONS	

DIMENSION STYLE INCH/MM	
DRAWN BY	DATE
HRUIZ01	2015/03/19
CHECKED BY	DATE
HKNEELAN	2015/03/19
APPROVED BY	DATE
JFMURPHY	2015/06/12
MATERIAL NO.	SEE TABLE
SIZE	A

SCALE NTS	DESIGN UNITS INCH	THIRD ANGLE PROJECTION
TITLE PULLING GRIPS FIBER OPTIC ROTATING EYE		
MOLEX INCORPORATED		
MATERIAL NO.	DOCUMENT NO.	SHEET NO.
SEE TABLE	SD-130095-118	1 OF 1
THIS DRAWING CONTAINS INFORMATION THAT IS PROPRIETARY TO MOLEX INCORPORATED AND SHOULD NOT BE USED WITHOUT WRITTEN PERMISSION		