

## ADS1158EVM, ADS1258EVM, ADS1158EVM-PDK, and ADS1258EVM-PDK

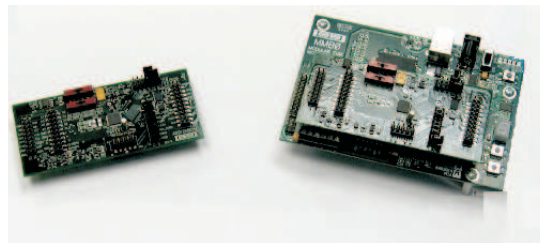

**Figure 1. ADS1258EVM (Left) and ADS1258EVM-PDK (Right)**

This user's guide describes the characteristics, operation, and use of the ADS1158EVM and ADS1258EVM, both separately and as part of the ADS1158EVM-PDK or ADS1258EVM-PDK. These evaluation modules (EVMs) are evaluation board for the [ADS1258](#) multi-channel, delta-sigma ( $\Delta\Sigma$ ), analog-to-digital converter (ADC), and the [ADS1158](#), a 16-bit version of the ADS1258. It allows evaluation of all aspects of the ADS1158 or ADS1258 device. Complete circuit descriptions, schematic diagrams, and bills of materials are included in this document.

The related documents listed in [Table 1](#) are available through the Texas Instruments web site at [www.ti.com](http://www.ti.com).

**Table 1. EVM-Compatible Device Data Sheets**

Device	Literature Number	Device	Literature Number
<a href="#">ADS1158</a>	<a href="#">SBAS429B</a>	<a href="#">TPS79225</a>	<a href="#">SLVS337B</a>
<a href="#">ADS1258</a>	<a href="#">SBAS297D</a>	<a href="#">SN74AHCT1G04</a>	<a href="#">SCLS319N</a>
<a href="#">REF1004</a>	<a href="#">SBVS002</a>	<a href="#">SN74LVC1G07</a>	<a href="#">SCES296V</a>
<a href="#">DAC8571</a>	<a href="#">SLAS373A</a>	<a href="#">TPS72325</a>	<a href="#">SLVS346B</a>
<a href="#">OPA301</a>	<a href="#">SBOS271D</a>	<a href="#">SN74AVC2T45</a>	<a href="#">SCES531J</a>
<a href="#">SN74LVC1G126</a>	<a href="#">SCES224N</a>	<a href="#">SN74AVC8T245</a>	<a href="#">SCES517H</a>

## Contents

1	EVM Overview .....	3
2	Analog Interface.....	4
3	Digital Interface .....	5
4	Power Supplies .....	7
5	Voltage Reference.....	8
6	Clock Source .....	8
7	EVM Operation.....	9
8	ADS1258EVM-PDK Kit Operation .....	11
9	Evaluating with the ADCPro Software.....	26
10	Schematics and Layout.....	35

## List of Figures

1	ADS1258EVM (Left) and ADS1258EVM-PDK (Right) .....	1
2	J3 Pin Configuration.....	6
3	ADS1258EVM Default Jumper Locations.....	10
4	MMB0 Initial Setup .....	12
5	Connecting the ADS1258EVM to the MMB0 .....	13
6	Connecting an AC Adapter .....	14
7	Laboratory Power-Supply Connection .....	15
8	NI-VISA Driver Installation .....	17
9	NI-VISA Driver Installation Question.....	18
10	NI-VISA Driver Installing.....	19
11	NI-VISA Driver Complete Installation .....	20
12	NI-VISA Driver Verification Using Device Manager.....	20
13	ADCPro Software Start-up Display Window .....	21
14	ADS1258EVM-PDK Plug-In Display Window.....	22
15	Install New Driver Wizard Screen 1.....	23
16	Install New Driver Wizard Screen 2.....	23
17	Install New Driver Wizard Screen 3.....	24
18	Install New Driver Wizard Screen 4.....	24
19	Install New Driver Wizard Screen 5.....	25
20	USBSytx Driver Verification Using Device Manager.....	25
21	Mux Settings for Fixed Channel Mode .....	27
22	Mux Settings for Auto Channel Mode .....	28
23	Switch Delay Settings.....	29
24	External Chopping.....	29
25	Chopping Settings.....	30
26	Clock Settings .....	31
27	GPIO Controls .....	32
28	Power and Reference Settings .....	33
29	Progress Bar While Collecting Data .....	34

## List of Tables

1	EVM-Compatible Device Data Sheets .....	1
2	J1—Analog Interface Pinout.....	4
3	J2—Supplemental Analog Interface Pinout .....	5
4	J6—Serial Interface Pins .....	6
5	J5 Configuration—Power-Supply Input .....	7

6	J4 Configuration—Power Options .....	7
7	Reference Selection .....	8
8	List of Switches .....	10
9	ADS1258EVM Bill of Materials .....	35

## 1 EVM Overview

### 1.1 Features

#### ADS1158EVM/ADS1258EVM Features:

- Contains all support circuitry needed for the ADS1158/ADS1258
- Electronically switchable power supply allows both bipolar and unipolar configuration
- Voltage reference options: external or onboard digital-to-analog (DAC)-controlled programmable reference
- Clock options: ADS1158/ADS1258 built-in PLL-based oscillator or external clock signal
- GPIO access
- Compatible with the [TI Modular EVM System](#)

#### ADS1158EVM-PDK/ADS1258EVM-PDK Features:

- Easy-to-use evaluation software for Microsoft® Windows®
- Data collection to ASCII text files
- Built-in analysis tools including scope, FFT, and histogram displays
- Complete control of board settings
- Easily expandable with new analysis plug-in tools from Texas Instruments

For use with a computer, the ADS1158EVM-PDK or ADS1258EVM-PDK is available. This kit combines the ADS1158EVM/ADS1258EVM board with the DSP-based MMB0 motherboard.

The MMB0 motherboard allows the ADS1158EVM/ADS1258EVM to be connected to the computer via an available USB port. This manual shows how to use the MMB0 as part of the ADS1158EVM-PDK/ADS1258EVM-PDK, but does not provide technical detail on the MMB0 itself.

ADCPro™ is a program for collecting, recording, and analyzing data from ADC evaluation boards. It is based on a number of plug-in programs, so it can be expanded easily with new test and data collection plug-ins. The ADS1158EVM-PDK/ADS1258EVM-PDK is controlled by a plug-in running in ADCPro. For more information about ADCPro, see the [ADCPro™ Analog-to-Digital Converter Evaluation Software User's Guide](http://focus.ti.com/lit/ug/sbau128/sbau128.pdf) (<http://focus.ti.com/lit/ug/sbau128/sbau128.pdf>), available for download from the TI web site.

This manual covers the operation of both the ADS1158EVM/ADS1258EVM and the ADS1158EVM-PDK/ADS1258EVM-PDK. It does not describe the MMB0 motherboard in detail. Throughout this document, the abbreviation *EVM* and the term *evaluation module* are synonymous with the ADS1158EVM/ADS1258EVM. For clarity of reading, this manual will refer only to the ADS1258EVM or ADS1258EVM-PDK, but operation of the EVM and kit for the ADS1158 is identical, unless otherwise noted.

## 1.2 Introduction

The ADS1258EVM is an evaluation module built to the [TI Modular EVM System](#) specification. It can be connected to any Modular EVM System interface card.

The ADS1258EVM is available as a stand-alone printed circuit board (PCB) or as part of the ADS1258EVM-PDK, which includes an MMB0 motherboard. As a stand-alone PCB, the ADS1258EVM is useful for prototyping designs and firmware.

Note that the ADS1258EVM has no microprocessor and cannot run software. To connect it to a computer, some type of interface is required.

## 2 Analog Interface

For maximum flexibility, the ADS1258EVM is designed for easy interfacing to multiple analog sources. Samtec part numbers SSW-110-22-F-D-VS-K and TSM-110-01-T-DV-P provide a convenient 10-pin, dual-row, header/socket combination at J1. This header/socket provides access to the analog input pins of the ADS1258, as shown in [Table 2](#). Consult Samtec at [www.samtec.com](http://www.samtec.com) or call 1-800-SAMTEC-9 for a variety of mating connector options.

In addition to J1, the J2 header (Samtec part number TSW-108-07-L-D) provides additional analog inputs to accommodate the large number of input channels available on the ADS1258. Most of the pins on J1 and J2 are directly connected, with no filtering or protection. Use appropriate caution when handling these pins.

**Table 2. J1—Analog Interface Pinout**

PIN NUMBER	SIGNAL	DESCRIPTION
J1.1	A1	AIN1, ADS1258
J1.2	A0	AIN0, ADS1258
J1.3	A3	AIN3, ADS1258
J1.4	A2	AIN2, ADS1258
J1.5	A5	AIN5, ADS1258
J1.6	A4	AIN4, ADS1258
J1.7	A7	AIN7, ADS1258
J1.8	A6	AIN6, ADS1258
J1.10	J2.11	Connected to J2, pin 11
J1.18	EXTREFN	External reference source input (– side of differential input)
J1.20	EXTREFP	External reference source input (+ side of differential input)
J1.12–J1.16 (even)	Unused	
J1.15	Unused	
J1.9–J19 (odd)	AGND	Analog ground connections (except J1.15)

The AINCOM and multiplexer bypass pins are brought to J2, as shown in [Table 3](#). AINCOM is connected to pin 12 on J2. An additional connection is made between J2.11 and J1.10; as a result of this connection, if J2.11 and J2.12 are shorted, and J1.9 and J1.10 are shorted, AINCOM is grounded; if only J2.11 and J2.12 are shorted, AINCOM is available on the EVM analog connector.

The multiplexer bypass is available at J2.13–J2.14 (MUXOUP) and J2.15–J2.16 (MUXOUN). Shorting these pairs of pins routes the multiplexer output back to the ADCINN and ADCINP pins through a differential filter. Alternatively, a signal can be applied directly to ADCINN and ADCINP through the filter.

**Table 3. J2—Supplemental Analog Interface Pinout**

PIN NUMBER	SIGNAL	DESCRIPTION
J2.1–J2.2	GND	Analog ground
J2.3	A8	AIN8, ADS1258
J2.4	A9	AIN9, ADS1258
J2.5	A10	AIN10, ADS1258
J2.6	A11	AIN11, ADS1258
J2.7	A12	AIN12, ADS1258
J2.8	A13	AIN13, ADS1258
J2.9	A14	AIN14, ADS1258
J2.10	A15	AIN15, ADS1258
J2.11	J1.10	Connected to J1, pin 10
J2.12	ACOM	AINCOM, ADS1258
J2.13	ANP	ADCINP, ADS1258
J2.14	MOP	MUXOUP, ADS1258
J2.15	ANN	ADCINN, ADS1258
J2.16	MON	MUXOUN, ADS1258

## 3 Digital Interface

### 3.1 Serial Data Interface

The ADS1258EVM is designed to easily interface with multiple control platforms. Samtec part numbers SSW-110-22-F-D-VS-K and TSM-110-01-T-DV-P provide a convenient 10-pin, dual-row, header/socket combination at J6. This header/socket provides access to the digital control and serial data pins of the TSC. Consult Samtec at [www.samtec.com](http://www.samtec.com) or call 1-800-SAMTEC-9 for a variety of mating connector options.

All logic levels on J6 are 3.3V CMOS, except for the I<sup>2</sup>C pins, which conform to 3.3V I<sup>2</sup>C rules. The ADS1258 may run at different logic levels, as set using J4. All ADS1258 pins are therefore level-shifted.

Many pins on J6 have weak pull-up resistors. These resistors provide default settings for many of the control pins. Many pins on J6 correspond directly to ADS1258 pins, as shown in [Table 4](#). See the [ADS1258 data sheet](#) for complete details on these pins.

**Table 4. J6—Serial Interface Pins**

PIN NUMBER	PIN NAME	SIGNAL NAME	I/O TYPE	PULL-UP	FUNCTION
J6.1	CNTL	CNTL	In	None	Optional ADS1258 START pin control; see text
J6.2	GPIO0	PDWN	In	High	ADS1258 power-down pin
J6.3	CLKX	SCLK	In	None	ADS1258 SPI clock
J6.4	DGND	DGND	In/Out	None	Digital ground
J6.5	CLKR	—	—	None	Unused
J6.6	GPIO1	RST	In	High	ADS1258 reset pin
J6.7	FSX	CS	In	Low	Optional ADS1258 chip-select control; see text
J6.8	GPIO2	CLKSEL	In	High	Clock select: 0 = internal / out, 1 = external
J6.9	FSR	—	—	None	Unused
J6.10	DGND	DGND	In/Out	None	Digital ground
J6.11	DX	DIN	In	None	ADS1258 SPI data in
J6.12	GPIO3	N/A	In	High	Power-supply mode: 0 = bipolar, 1 = unipolar
J6.13	DR	DOUT	Out	None	ADS1258 SPI data out
J6.14	GPIO4	—	—	None	Unused
J6.15	TINT	DRDY	Out	None	ADS1258 data-ready output
J6.16	SCL	SCL	I <sup>2</sup> C	N/A	I <sup>2</sup> C clock
J6.17	TOUT	CLK	In	None	External clock input
J6.18	DGND	DGND	In/Out	None	Digital ground
J6.19	GPIO5	—	—	None	Unused
J6.20	SDA	SDA	I <sup>2</sup> C	N/A	I <sup>2</sup> C data

### 3.2 GPIO

The GPIO connector, J3, carries the GPIO pins for the ADS1258. J3 is arranged so that GPIO0 and GPIO1 can be used to control START and CS, respectively; see [Figure 2](#) and [Figure 5](#). The PDK firmware controls START through GPIO0. CNTL(J6-1) and FSX(J6-7) are also brought to J3, so they can also be used to control START and CS. Both FSX and CNTL are pulled down, so these pins can be used to keep START and CS low if they are not to be used.

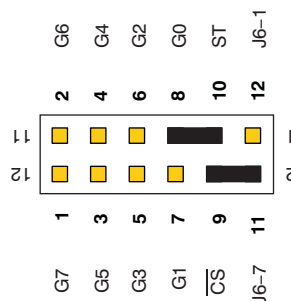

**Figure 2. J3 Pin Configuration**

## 4 Power Supplies

J5 is the power-supply input connector, as shown in [Table 5](#).

**Table 5. J5 Configuration—Power-Supply Input**

PIN NUMBER	PIN NAME	FUNCTION	REQUIRED?
J5.1	+VA	Not used	No
J5.2	-VA	Not used	No
J5.3	+5VA	+5V analog supply	Always
J5.4	-5VA	-5V analog supply	Only in bipolar mode
J5.5	DGND	Digital ground input	Only if DGND is selected on J4
J5.6	AGND	Analog ground input	Only if AGND is selected on J4
J5.7	+1.8VD	1.8V digital supply	Only if 1.8V is selected on J4
J5.8	VD1	Not used	No
J5.9	+3.3VD	3.3V digital supply	Always
J5.10	+5VD	Not used	No

### 4.1 Power Options

J4 is arranged as seven rows, each of which can be shorted, as shown in [Table 6](#). For normal operation, J4.1-2, J4.3-4, and J4.9-10 must be connected (directly or through an ammeter); either J4.5-6 or J4.7-8 must be connected, and either (or both) of J4.11-12 and J4.13-14 must be connected; otherwise, the board will not function.

**Table 6. J4 Configuration—Power Options**

ROW	NAME	FUNCTION
1-2	ADC AVDD	AVDD supply current measurement point for the ADC. Must be connected for operation.
3-4	ADC AVSS	AVSS supply current measurement point for the ADC. Must be connected for operation.
5-6	1.8V select	When shorted, DVDD is sourced from the 1.8V power-supply input pin. Should not be connected at the same time as 7-8.
7-8	3.3V select	When shorted, DVDD is sourced from the 3.3V power-supply input pin. Should not be connected at the same time as 5-6.
9-10	ADC DVDD	DVDD supply current measurement point for the ADC. Must be connected for operation.
11-12	DGND	Connects DGND to board ground.
13-14	AGND	Connects AGND to board ground.

## 5 Voltage Reference

The ADS1258EVM has a DAC-controlled voltage reference circuit. The DAC used is a TI [DAC8571](#), controlled through the I<sup>2</sup>C. The address is set to 1001100. The output of the DAC is multiplied by two, giving a range of approximately 0V to 5V. The DAC circuit is designed for low drift, but is uncalibrated. For absolute accuracy, measure the DAC output and adjust as needed. The DAC high resolution reduces the need for mechanical trimming.

Because of the high capacitance load on the buffer amplifier, the DAC step must be limited. The code must not be changed by more than one at a time. (The PDK firmware incorporates a stepper task that limits the slew-rate of the DAC by software.) If the DAC step is too high, the circuit saturates at a certain voltage. To reset the circuit, return the DAC output to 0V.

Switches S1 and S2 allow various combinations of the DAC, external supply pins, and the power supply to be selected, as shown in [Table 7](#).

**Table 7. Reference Selection**

POSITION	S1 REFP	S2 REFN
Left	AVDD	AVSS
Center	DAC	GND
Right	EXTREFP (J1.20)	EXTREFN (J1.18)

## 6 Clock Source

The ADS1258 can use either an internal PLL-based clock source or an externally supplied clock. The ADS1258EVM supports either type of clock.

For PLL operation, the ADS1258EVM is supplied with a 32.768kHz crystal. This clock mode is selected by pulling GPIO2 on J6 (pin 8) low. In this mode, the generated clock can be measured on TP1, if the proper bit is set in the ADS1258. The clock does not interfere with TOUT.

For external operation, a clock signal must be supplied on TOUT on J6 (pin 17), and GPIO2 must be driven high. The level-shifted clock can be measured at TP1.



## 7 EVM Operation

The following sections provide information on the analog input, digital control, and general operating conditions of the ADS1258EVM.

### 7.1 Analog Input

The analog input sources can be applied directly to J1 (top or bottom side) or through signal-conditioning modules available for the the modular EVM system. Signals can be applied directly to J2 for the additional available channels.

### 7.2 Digital Control

The digital control signals can be applied directly to J6 (top or bottom side). The modular ADS1258EVM can also be connected directly to a DSP or microcontroller interface board, such as the [5-6KInterface](#) or [HPA-MCUInterface](#) boards available from Texas Instruments, or the MMB0 if purchased as part of the ADS1258EVM-PDK. For a list of compatible interface and/or accessory boards for the EVM, the ADS1258, or the ADS1158, see the relevant product folder on the TI web site ([www.ti.com](http://www.ti.com)).

### 7.3 Power Supply

The ADS1258 device can operate in either unipolar or bipolar mode. The ADS1258EVM can therefore function in one of two power-supply configurations, unipolar or bipolar.

- In **unipolar** mode, the ADS1258 device uses a 5V analog supply. No negative power supply is needed in this mode. The PDK requires a +5V dc supply that can be derived from a wall-mount power adapter.
- In **bipolar** mode, the ADS1258 is powered from a  $\pm 2.5$ V dual supply. This configuration requires both a +5V supply and a -5V supply.

The power-supply mode is selected using GPIO3 (pin 12) on J6 of the ADS1258EVM. If this pin is low, the mode is bipolar; if high, the mode is unipolar. This pin is pulled high when nothing is connected.

### 7.4 Default Jumper Settings and Switch Positions

Figure 3 shows the jumpers found on the EVM and the factory default conditions for each one.

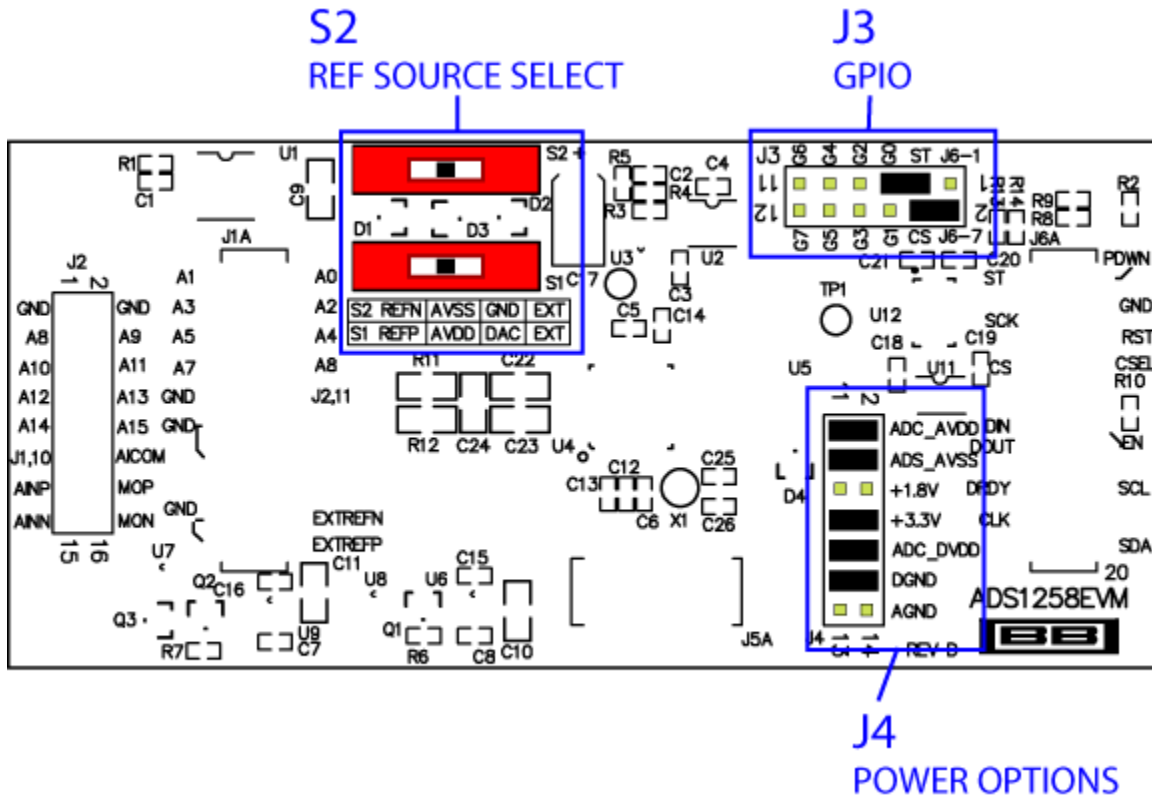

Figure 3. ADS1258EVM Default Jumper Locations

The jumpers on J4 provide a convenient way to measure the current for any of the power-supply currents: AVDD (analog +V power), DVDD (digital power), AVSS (analog –V power), or the ground connections VGND and DGND. Simply remove the jumper for the appropriate power supply and use a current meter between the jumper pins. The supply voltage for the digital supply (DVDD) can also be selected to be either 1.8V or 3.3V; see Table 6.

Table 8 provides a list of switches found on the EVM and the factory default conditions for each one.

Table 8. List of Switches

SWITCH	DEFAULT POSITION	SWITCH DESCRIPTION
S1	Left	REF positive
S2	Left	REF negative

## 8 ADS1258EVM-PDK Kit Operation

This section provides information on using the ADS1258EVM-PDK, including setup, program installation, and program usage.

To prepare to evaluate the ADS1258 with the ADS1258EVM-PDK, complete the following steps:

- Step 1. Install the ADCPro software (if not already installed).
- Step 2. Install the ADS1258EVM-PDK EVM plug-in software.
- Step 3. Set up the ADS1258EVM-PDK.
- Step 4. Connect a proper power supply or ac adapter.
- Step 5. Complete the NI-VISA USB driver installation process.
- Step 6. Run the ADCPro software.
- Step 7. Complete the Microsoft Windows USB driver installation process.

Each task is described in the subsequent sections of this document.

### 8.1 Installing the ADCPro Software

#### CAUTION

Do not connect the ADS1258EVM-PDK before installing the software on a suitable PC. Failure to observe this caution may cause Microsoft Windows to not recognize the ADS1258EVM-PDK.

The latest software download link is available from the TI website at <http://www.ti.com/tool/ADS1158EVM-PDK> or <http://www.ti.com/tool/ADS1258EVM-PDK>. Refer to the *ADCPro User's Guide* ([SBAU128](#)) for instructions on installing and using ADCPro.

To install the ADS1258EVM-PDK plug-in, run the file: **ads1258evm-pdk-plug-in-1.0.0.exe** (1.0.0 is the version number, and increments with software version releases). Double-click the file to run it and follow the instructions shown.

The software should now be installed, but the USB drivers may not yet have been loaded by the PC operating system. This step will complete when the ADCPro software is executed; see [Section 8.5](#), *Running the Software and Completing Driver Installation*.

## 8.2 Setting Up the ADS1258EVM-PDK

The ADS1258EVM-PDK contains both the ADS1258EVM and the MMB0 motherboard; however, the devices are shipped unconnected. Follow these steps to set up the ADS1258EVM-PDK:

- Step 1. Unpack the ADS1258EVM-PDK kit.
- Step 2. Set the jumpers and switches on the MMB0 as shown in [Figure 4](#):
  - Set the Boot Mode switch to *USB*.
  - Connect +5V and +5VA on jumper block J13 (if +5V is supplied from +5VA).
  - Leave +5V and +VA disconnected on jumper block J13.
  - If the PDK will be powered from an ac adapter, and used in unipolar mode, connect J12. If the PDK will be powered through the terminal block or will be used in bipolar mode, disconnect J12. (See [Section 8.4](#) for details on connecting the power supply.)

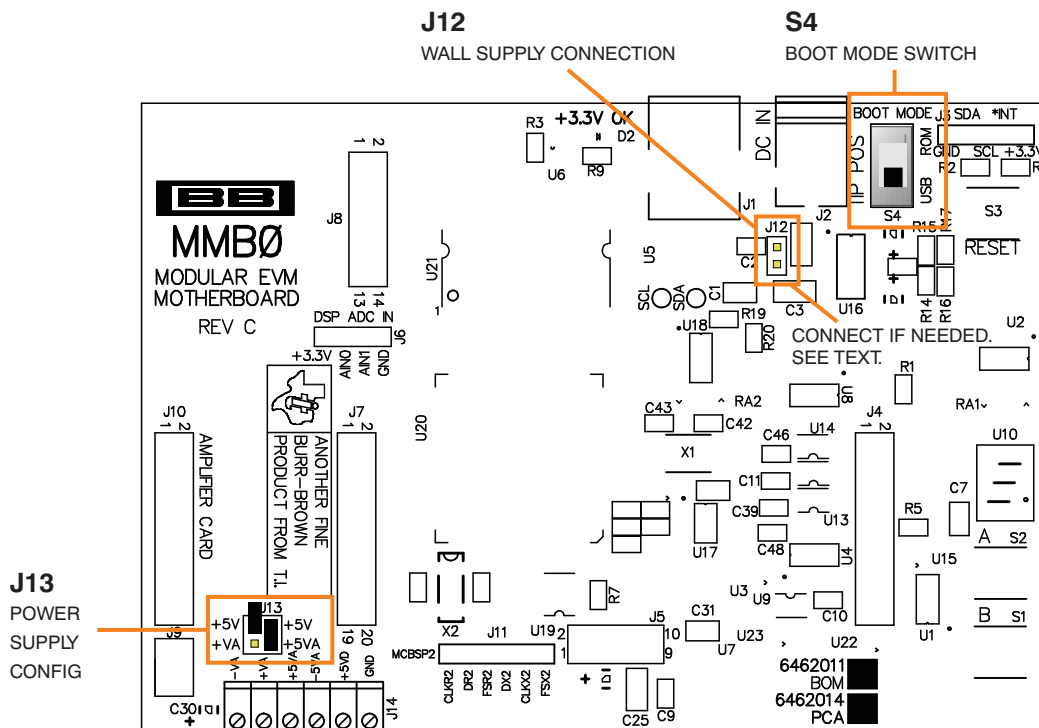
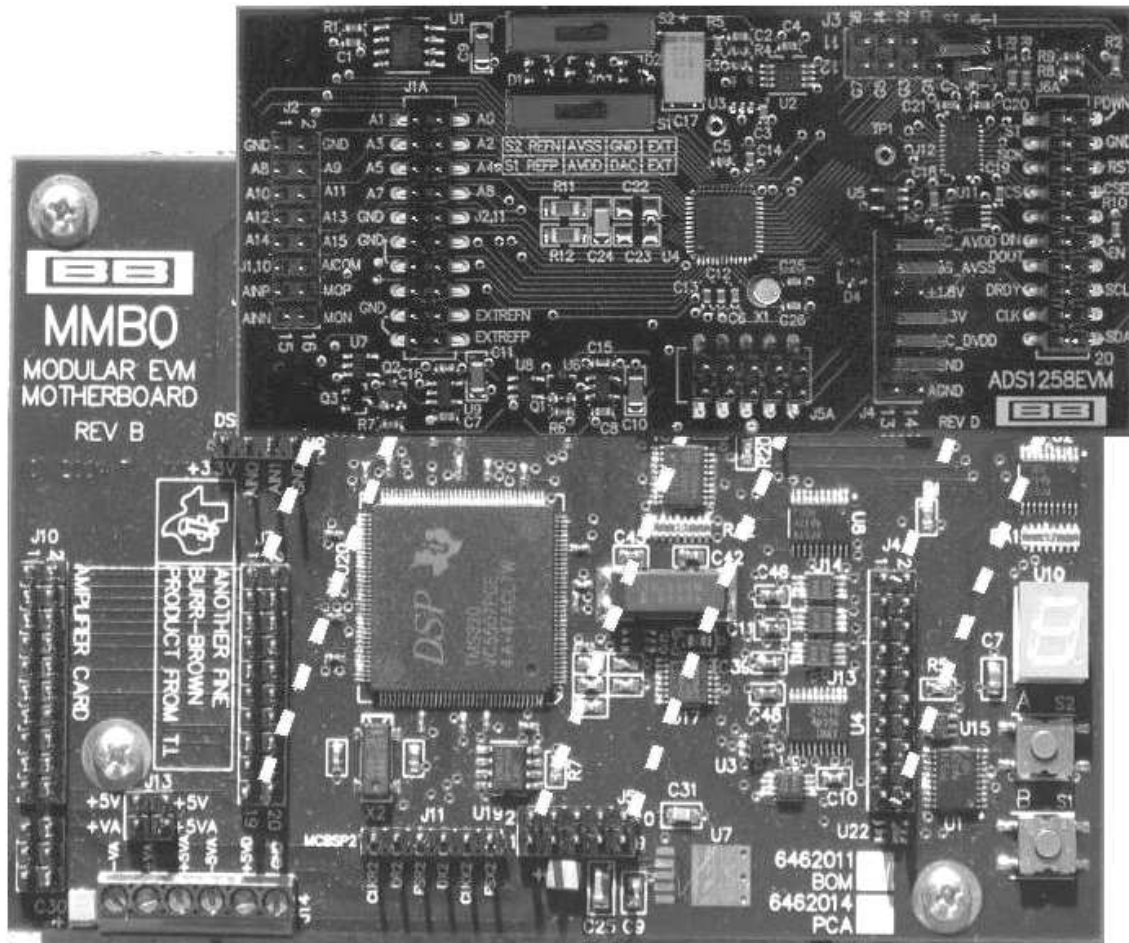

Figure 4. MMB0 Initial Setup

3. Plug the ADS1258EVM into the MMB0, as shown in [Figure 5](#).



**Figure 5. Connecting the ADS1258EVM to the MMB0**

**CAUTION**

Do not misalign the pins when plugging the ADS1258EVM into the MMB0. Check the pin alignment carefully before applying power to the PDK.

- Step 3. Set the jumpers and switches on the ADS1258EVM as illustrated in [Figure 3](#) (note that these settings are the factory-configured settings for the EVM):
- Set jumper block J4 as illustrated in [Figure 3](#).
  - Set the reference source select switches S1 and S2 to the center position.
  - Set up jumper block J3 as illustrated in [Figure 3](#).

### 8.3 About the MMB0

The MMB0 is a Modular EVM System motherboard. It is designed around the [TMS320VC5507](#), a DSP from Texas Instruments that has an onboard USB interface. The MMB0 also has 16MB of SDRAM installed.

The MMB0 is not sold as a DSP development board, and it is not available separately. TI cannot offer support for the MMB0 except as part of an EVM kit. For schematics or other information about the MMB0, contact Texas Instruments.

## 8.4 Connecting the Power Supply

The ADS1258EVM-PDK can be operated with a unipolar +5V supply or a bipolar  $\pm 5V$  supply.

If the ADS1258EVM-PDK is to be operated in unipolar mode only, either an ac adapter or a lab power supply can be used. If the ADS1258EVM-PDK is to be operated in bipolar mode, a  $\pm 5V$  power supply must be connected; an ac adapter cannot be used.

When the MMB0 DSP is powered properly, LED D2 glows green. The green light indicates that the 3.3V supply for the MMB0 is operating properly. (It does **not** indicate that the EVM power supplies are operating properly.)

### 8.4.1 Connecting an AC Adapter

An ac adapter can be connected to barrel jack J2 on the MMB0. J2 is located next to the USB connector. When an ac adapter is used, the ADS1258EVM cannot be used in bipolar mode. Refer to the [External Wall-Adapter Power-Supply Requirements](#) section.

Jumper J12 on the MMB0 connects a wall-mounted power supply to the board. J12 must be shorted to use the wall-mount supply, as shown in [Figure 6](#).

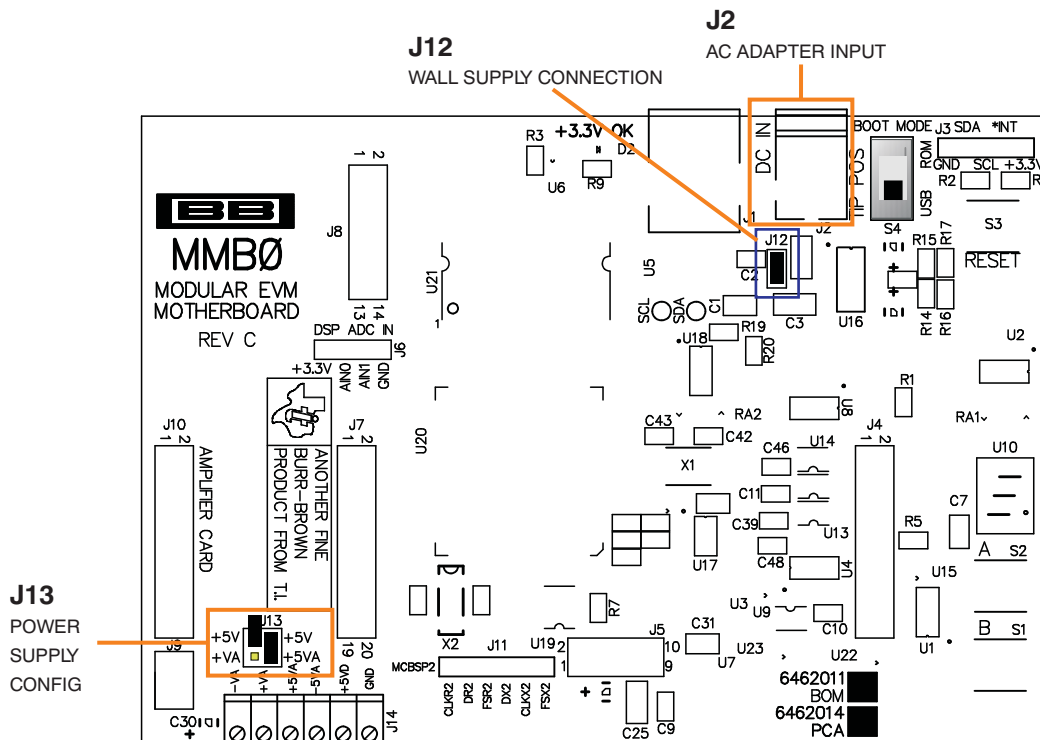

Figure 6. Connecting an AC Adapter

#### 8.4.1.1 External Wall-Adapter Power-Supply Requirements

The external wall-adapter power-supply requirements are as follows:

- Output voltage: 6 VDC to 9 VDC
- Maximum output current:  $\geq 500$  mA
- Output connector: barrel plug (positive center), 2.0-mm I.D.  $\times$  5.5-mm O.D. (9-mm insertion depth)

**NOTE:** Use an external power supply that complies with applicable regional safety standards; for example, UL, CSA, VDE, CCC, PSE, and so forth.

### 8.4.2 Connecting a Laboratory Power Supply

A laboratory power supply can be connected through terminal block J14 on the MMB0, as shown in Figure 7. Both unipolar and bipolar configurations are supported.

To use a unipolar lab power-supply configuration:

- Disconnect J12 on the MMB0.
- Connect a +5V dc supply to the +5VD terminal on J14.
- Connect ground of the dc supply to the GND terminal on J14.

For bipolar mode, also connect a -5V dc supply to the -5VA terminal on J14.

It is not necessary to connect +5V dc supply voltage to the +5VA terminal on J14 if the +5V/+5VA position on J13 is shorted.

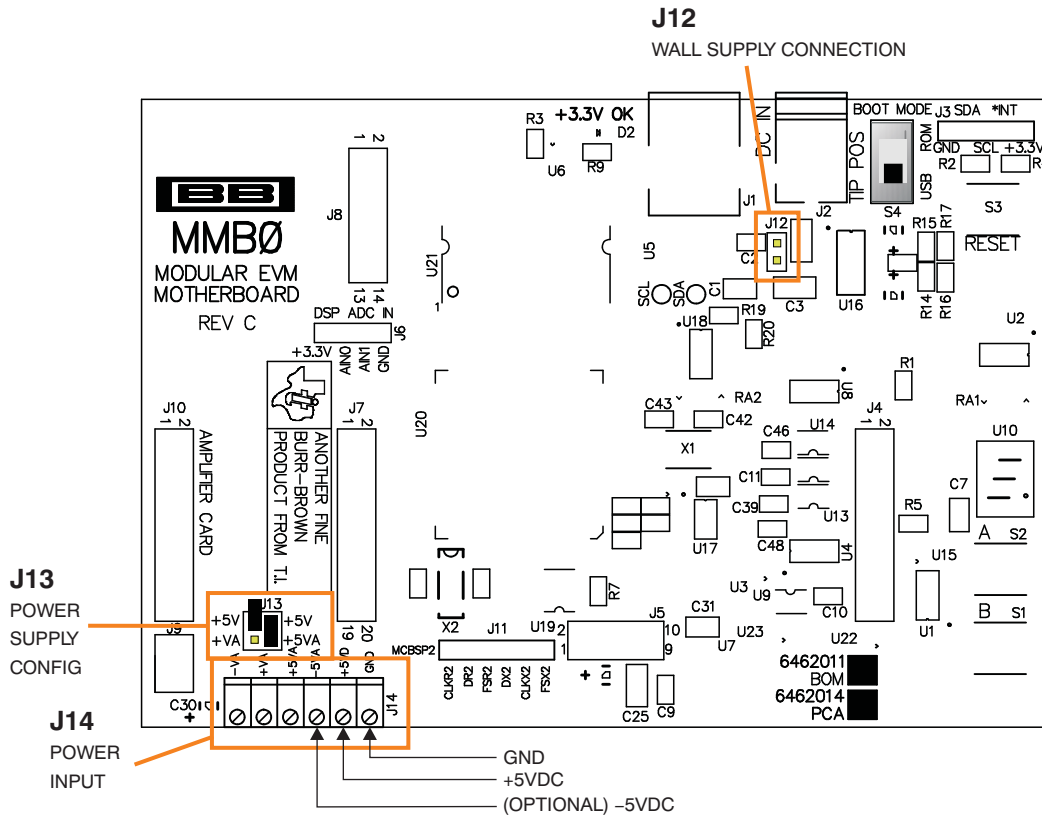

Figure 7. Laboratory Power-Supply Connection



## 8.5 Running the Software and Completing Driver Installation

---

**NOTE:** The software is continually under development. These instructions and screen images are current at the time of this writing, but may not exactly match future releases.

---

The program for evaluating the ADS1258EVM-PDK is called ADCPro. This program uses plug-ins to communicate with the EVM. The ADS1258EVM-PDK plug-in is included in the ADS1258EVM-PDK package.

The program currently runs only on Microsoft Windows platforms of Windows XP; Windows Vista is **NOT** supported.

If this is the first time installing ADCPro and plug-ins, follow these procedures to run ADCPro and complete the necessary driver installation. Make sure the ADCPro software and device plug-in software are installed from the CD-ROM as described in [Section 8.1](#), *Installing the ADCPro Software*.

### 8.5.1 NI-VISA USB Device Driver Installation

1. After the ADCPro software is installed, apply power to the PDK and connect the board to an available PC USB port.
2. The computer should recognize new hardware and begin installing the drivers for the hardware. [Figure 8](#) through [Figure 11](#) are provided for reference to show the installation steps.
  - For the first screen, [Figure 8](#), it is not necessary to search for the software; it has already been installed to your PC.
  - For the remaining steps, accept the default settings.



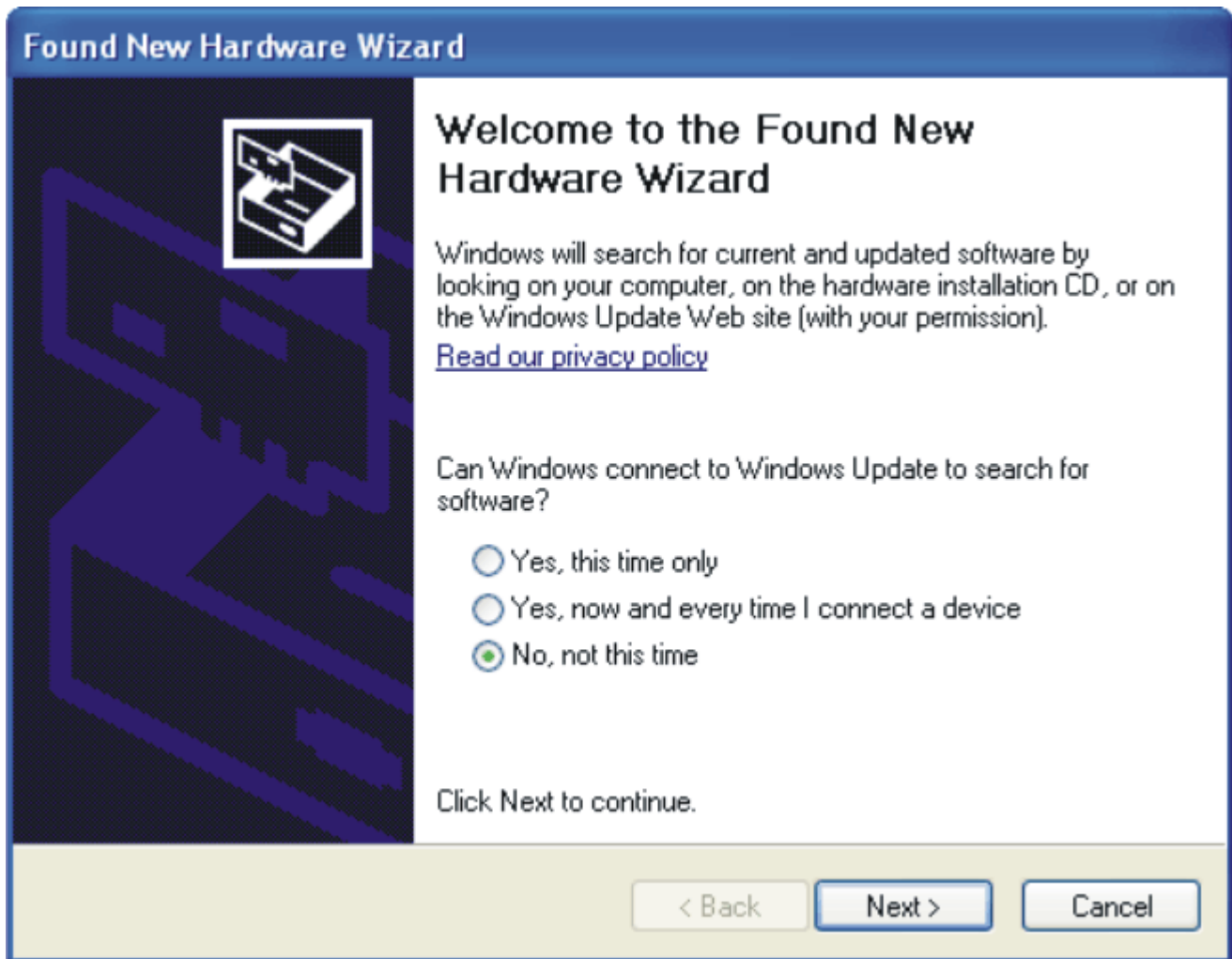

Figure 8. NI-VISA Driver Installation

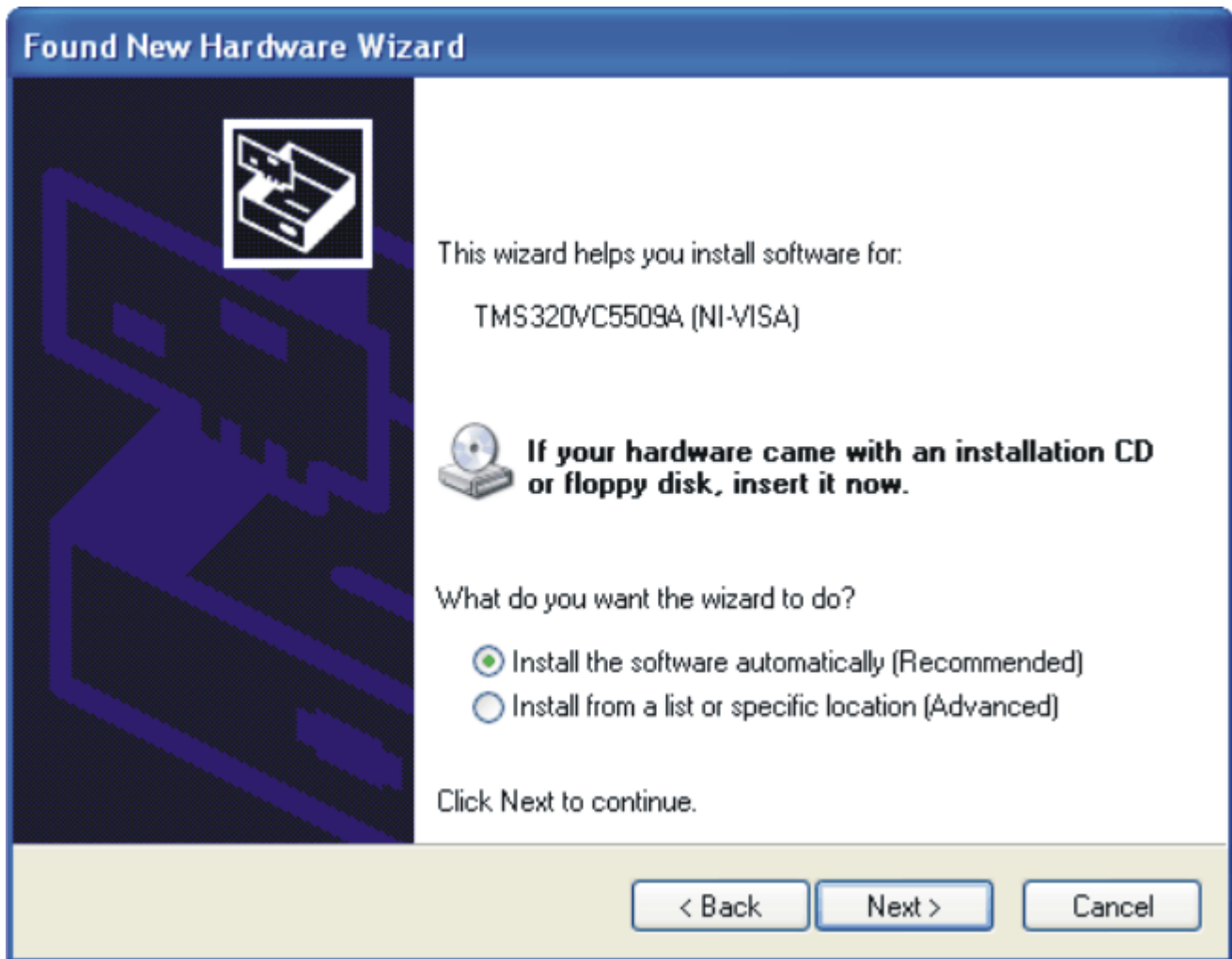

Figure 9. NI-VISA Driver Installation Question

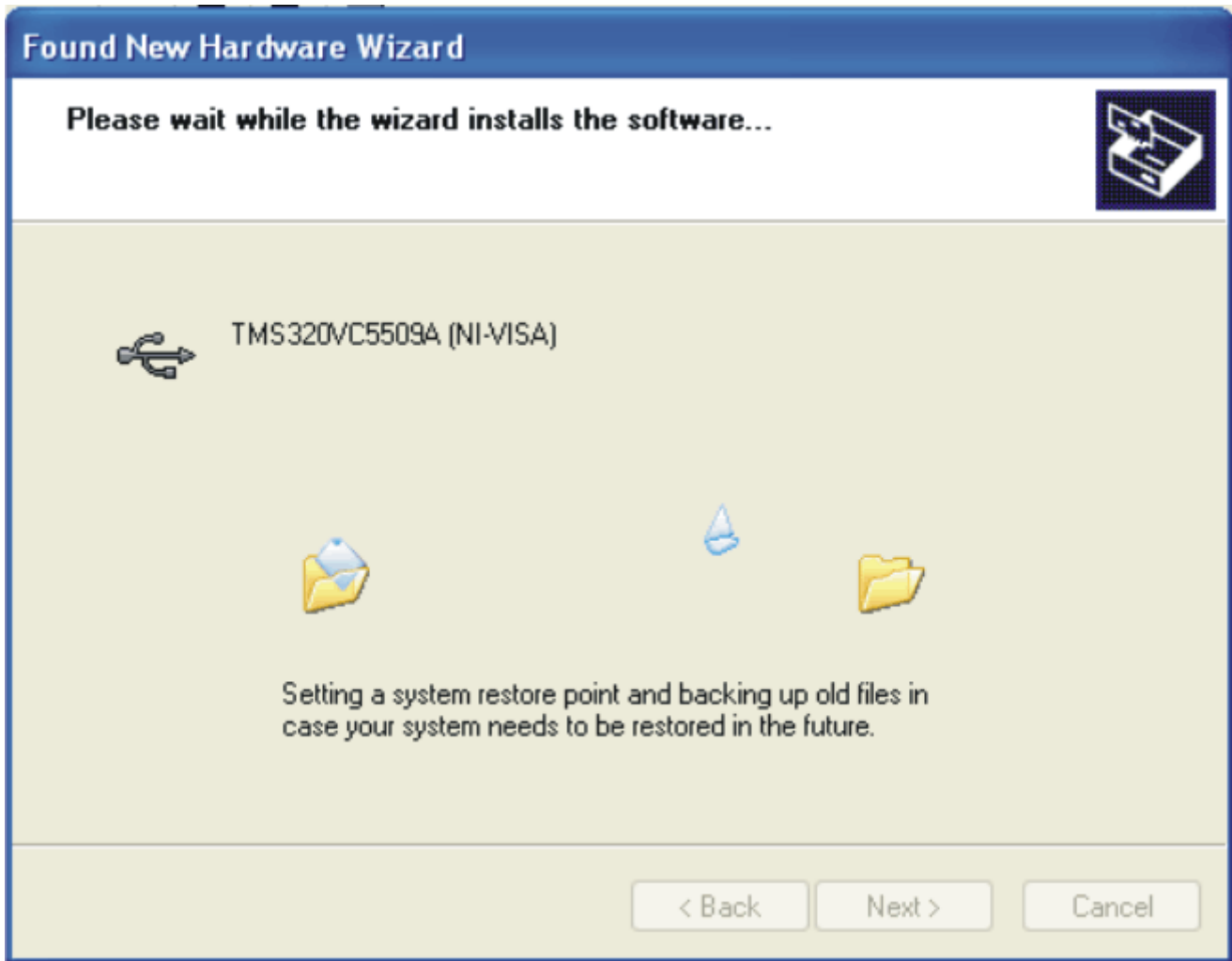
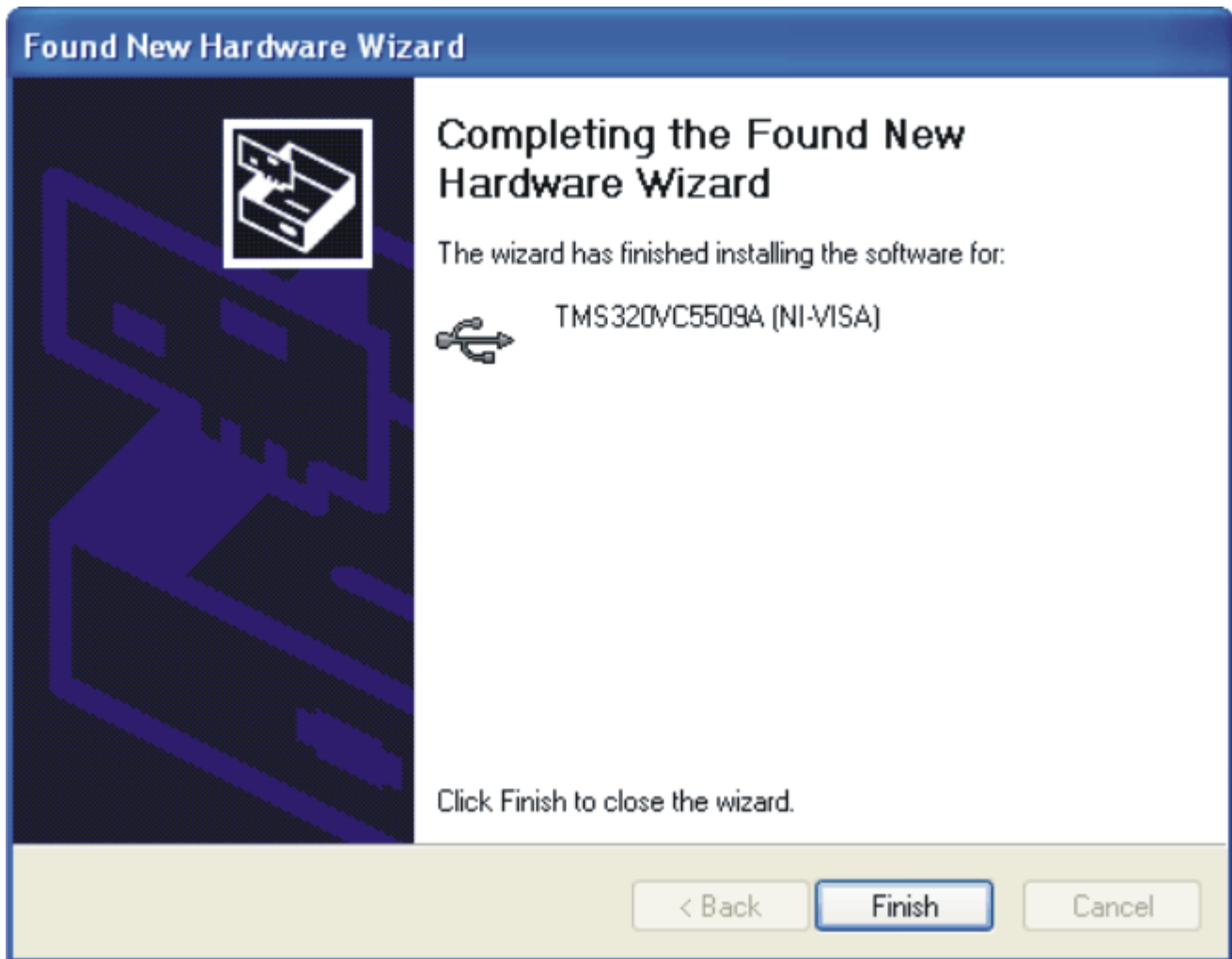

Figure 10. NI-VISA Driver Installing



**Figure 11. NI-VISA Driver Complete Installation**

This should complete the installation of the NI-VISA drivers. You can verify proper installation by opening the Device Manager and locating the driver as shown in [Figure 12](#).



**Figure 12. NI-VISA Driver Verification Using Device Manager**

### 8.5.2 USBStyx Driver Installation

1. Start the software by selecting *ADCPro* from the Windows Start menu. The screen in [Figure 13](#) appears.

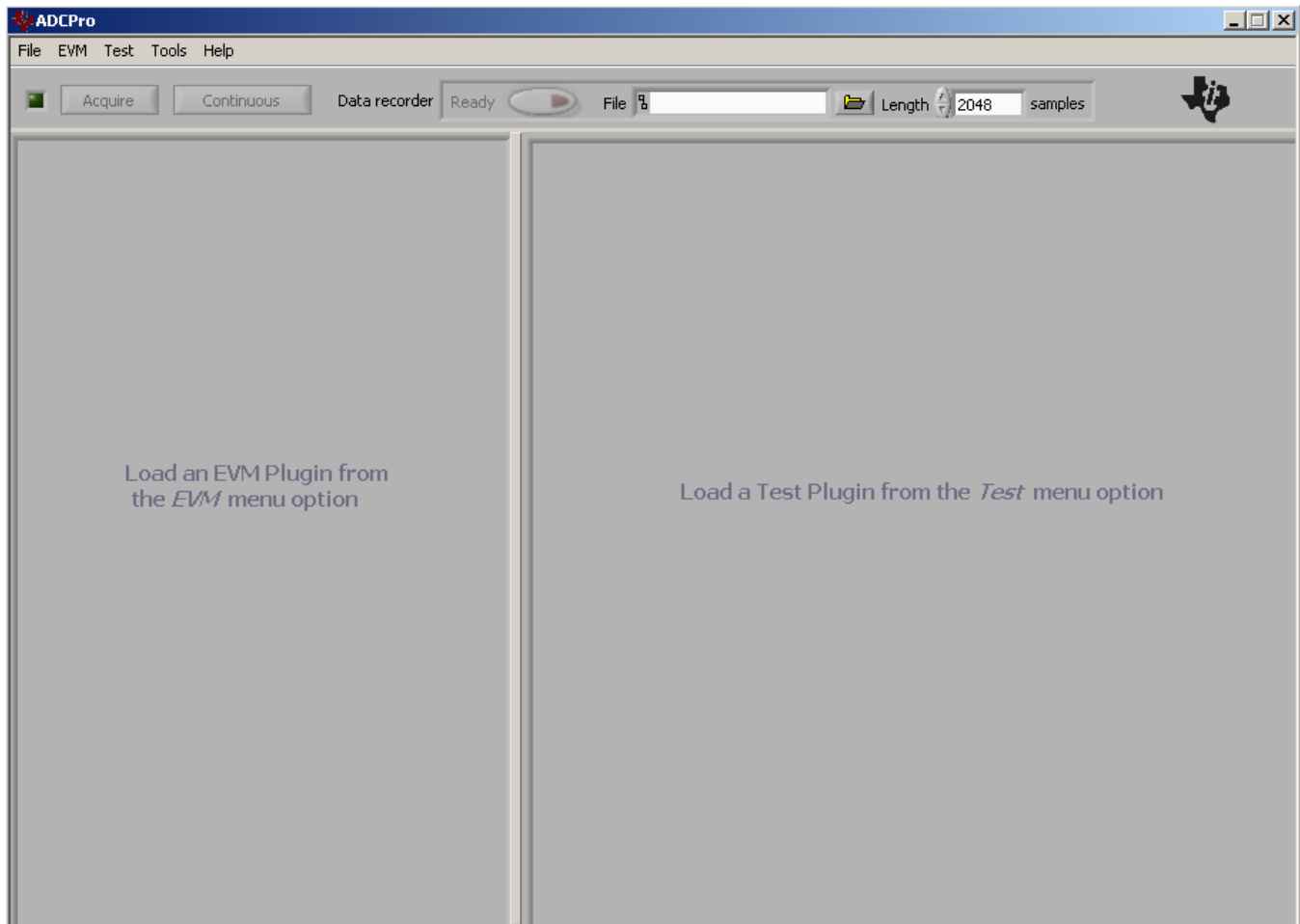

**Figure 13. ADCPro Software Start-up Display Window**

2. Select *ADS1258EVM* from the EVM drop-down menu. The ADS1258EVM-PDK plug-in appears in the left pane, as shown in [Figure 14](#).

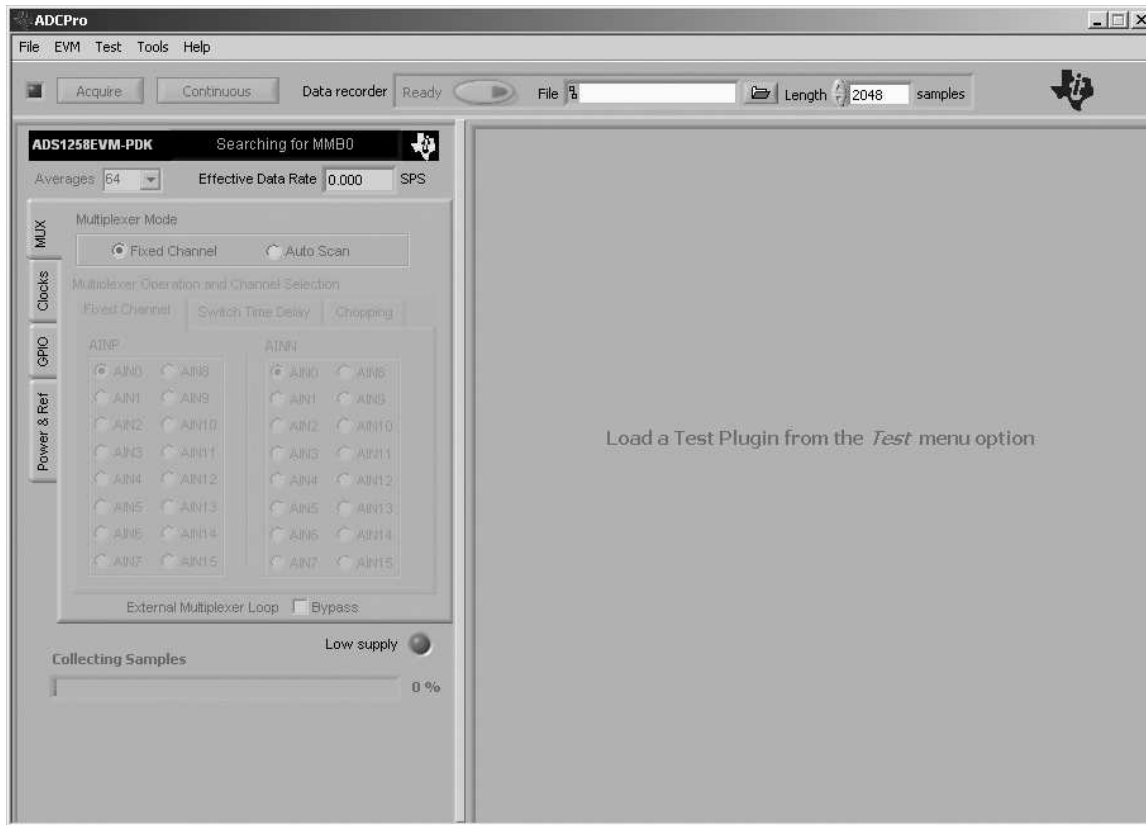

**Figure 14. ADS1258EVM-PDK Plug-In Display Window**

3. The ADS1258EVM-PDK plug-in window has a status area at the top of the screen. When the plug-in is first loaded, the plug-in searches for the board. You will see a series of messages in the status area indicating this action.
4. If you have not yet loaded the operating system drivers, Windows will display the Windows Install New Driver Wizard sequence (illustrated in [Figure 15](#) through [Figure 19](#)). Accept the default settings.

---

**NOTE:** During the driver installation, a message may appear indicating the firmware load has TIMED OUT. Click OK and continue driver installation. The plug-in will attempt to download the firmware again once the driver installation completes.

---

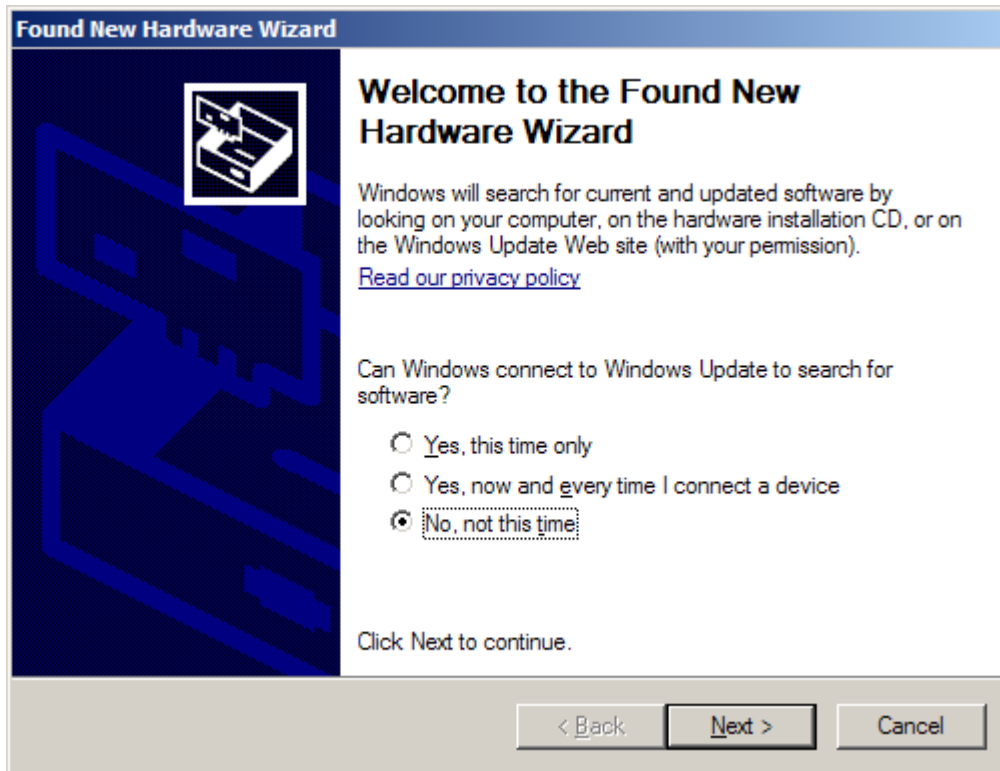

Figure 15. Install New Driver Wizard Screen 1

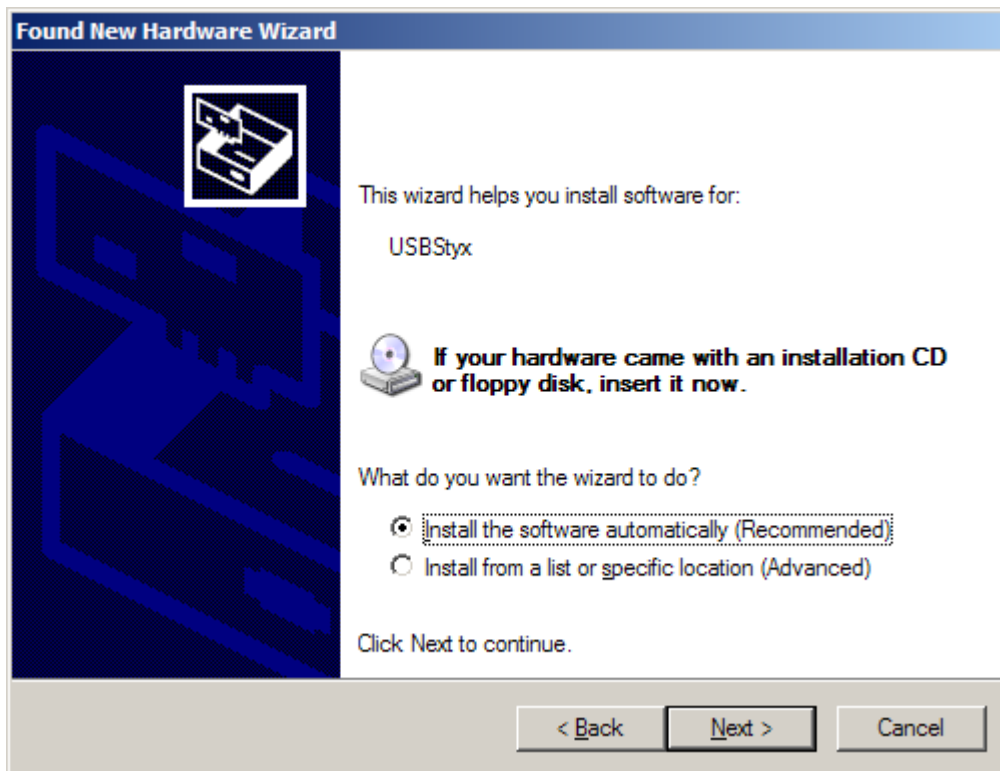

Figure 16. Install New Driver Wizard Screen 2

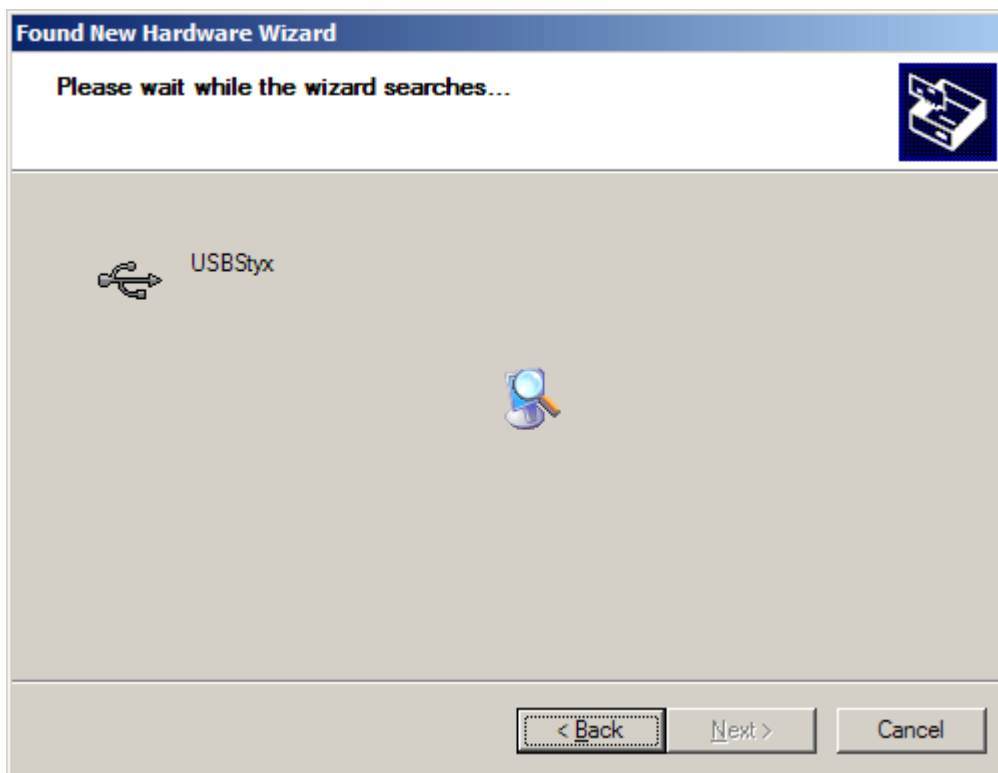

Figure 17. Install New Driver Wizard Screen 3

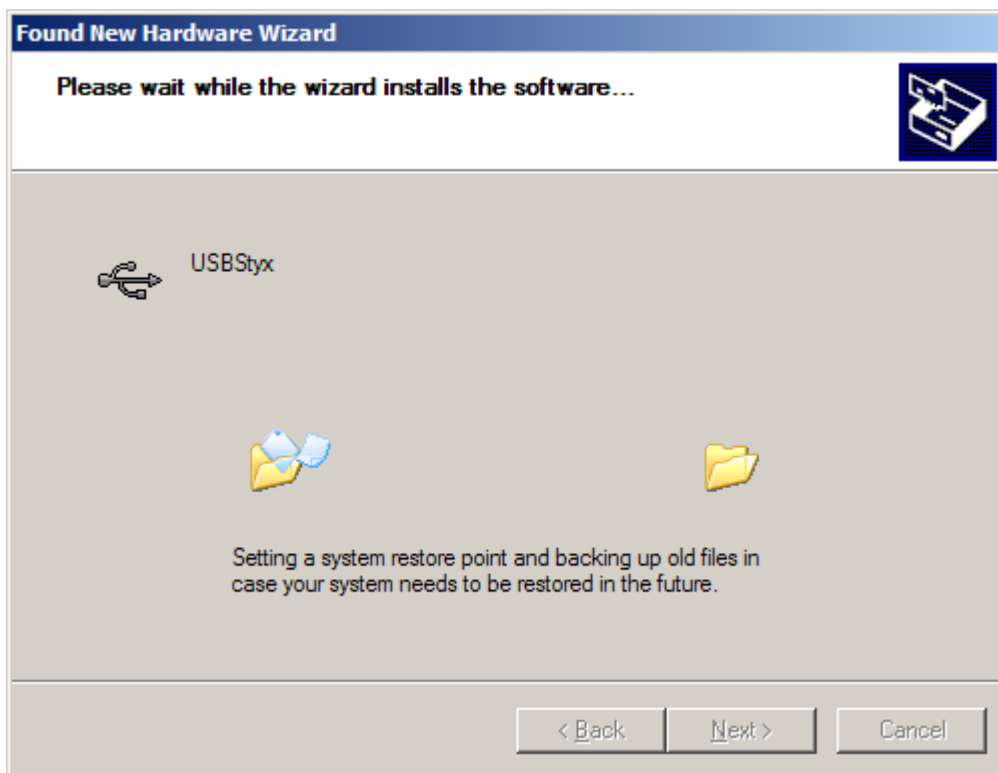
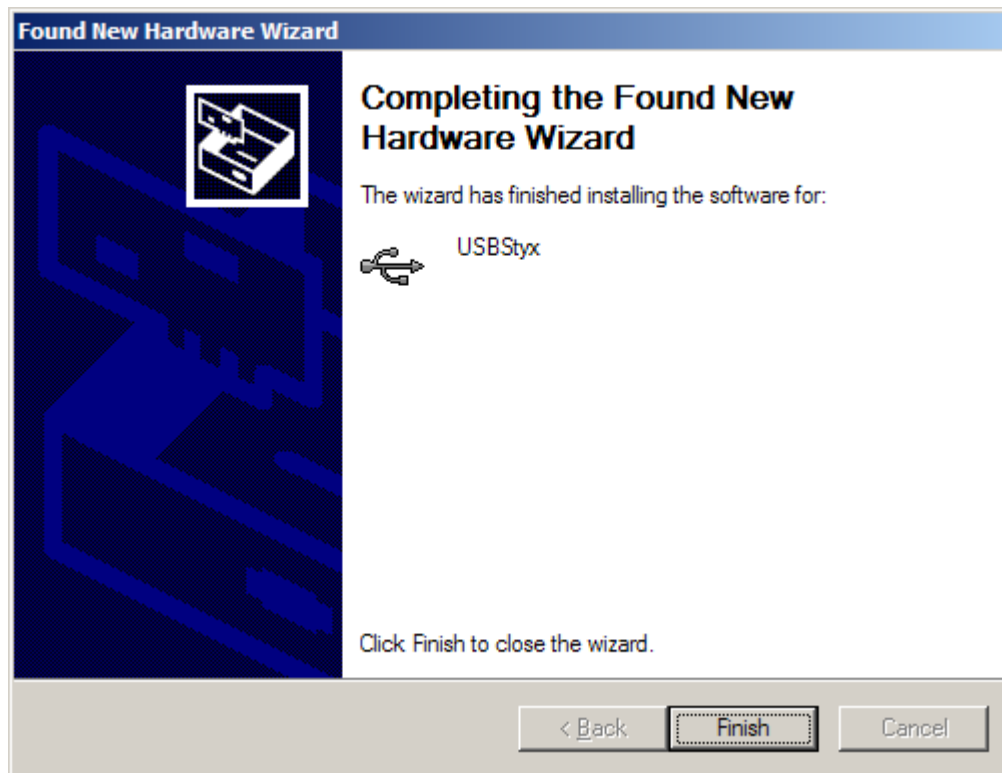

Figure 18. Install New Driver Wizard Screen 4





**Figure 19. Install New Driver Wizard Screen 5**

5. Once Windows finishes installing the software driver, the plug-in downloads the firmware to the MMB0. The status area will display *Connected to EVM* when the device is connected and ready to use. If the firmware does not load properly, you can try resetting the MMB0 by pressing reset and then reloading the plug-in.
6. You can verify the proper installation of the USBStyx driver using the Device Manager. Note that the first driver item, NI-VISA USB Devices, will disappear and a new item, LibUSB-Win32 Devices will appear, as [Figure 20](#) shows.



**Figure 20. USBStyx Driver Verification Using Device Manager**

The driver installation wizard sequence should not appear again, unless you connect the board to a different USB port.

## 9 Evaluating with the ADCPro Software

The evaluation software is based on ADCPro, a program that operates using a variety of plug-ins. (The ADS1258EVM plug-in is installed as described in the installation section.)

To use ADCPro, load an EVM plug-in and a test plug-in. To load an EVM plug-in, select it from the EVM menu. To load a test plug-in, select it from the **Test** menu. To unload a plug-in, select the **Unload** option from the corresponding menu.

Only one of each kind of plug-in can be loaded at a time. If you select a different plug-in, the previous plug-in is unloaded.

### 9.1 Using the ADS1258EVM-PDK Plugin

The ADS1258EVM-PDK plug-in for ADCPro provides complete control over all settings of the ADS1258. It consists of a tabbed interface (see [Figure 25](#)), with different functions available on different tabs. These controls are described in this section.

You can adjust the ADS1258EVM settings when you are not acquiring data. During acquisition, all controls are disabled and settings may not be changed. When you change a setting on the ADS1258EVM plug-in, the setting is immediately updated on the board. If you unload and reload the plug-in, the software will try to load settings from the board. Settings on the ADS1258EVM correspond to settings described in the ADS1258 data sheet; see the [ADS1258 data sheet](#) for details.

Because the effective data rate of the ADS1258 depends upon settings of the multiplexer mode, clocks, switch time delay, chopping, and averages, the **Effective Data Rate** indicator in the upper right corner of the plug-in interface is always visible and updated whenever a setting that effects the data rate is changed. In the upper left corner, the **Averages** control sets the ADS1258 averaging mode. This may be set to 1, 4, 16, or 64. Note that this is a setting for the ADS1258 device itself; no software averaging is done in the ADS1258EVM-PDK plug-in.

### 9.1.1 MUX Tab

The ADS1258 multiplexer can work in two modes, selected by the controls **Fixed Channel** or **Auto Scan**. When set to **Fixed Channel** mode, the screen will appear as shown in [Figure 21](#).

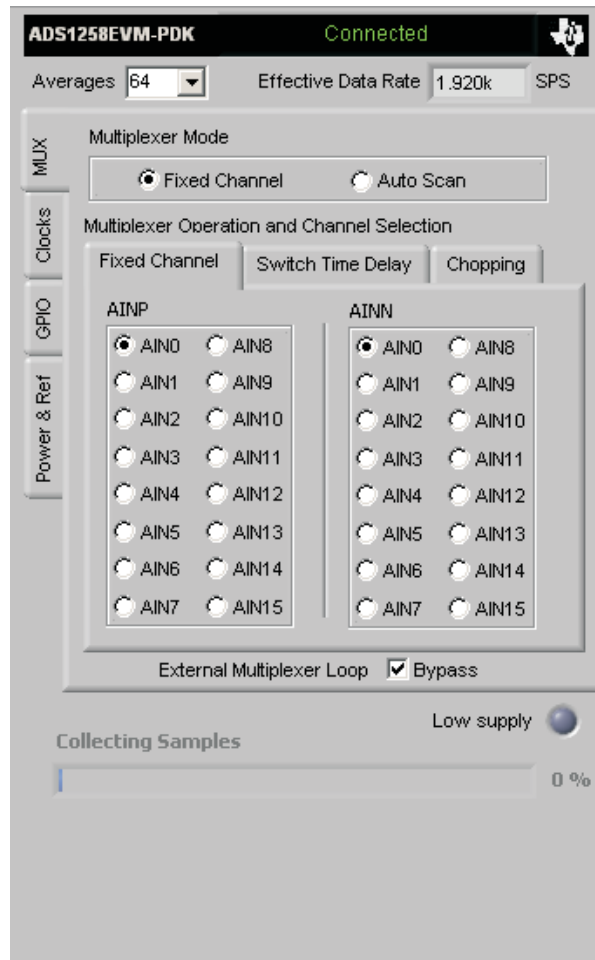

**Figure 21. Mux Settings for Fixed Channel Mode**

On the Fixed Channel tab, the AINP and AINN of the ADS1258 are connected to the pins selected by the radio buttons. In [Figure 18](#), these are both set to AIN0—not a useful setting for measuring an input signal, but quite commonly used for noise testing of the ADS1258. Any channel may be referenced to any other channel; for example, if AINP were set to AIN1, and AINN were set to AIN0, then the signal could be applied between AIN1 and AIN0.

When set to *Auto Scan* mode, the screen appears as shown in [Figure 22](#). In this mode, the ADS1258 scans through all of the channels selected by checking the box next to the channel name. Note that the AIN channels are single-ended channels, referred to AINCOM. See the [ADS1258 data sheet](#) for details on all of the channel configurations. Also notice when changing from *Fixed Channel* mode to *Auto Scan* mode, the data rate will be changed to match the limits of the ADS1258.

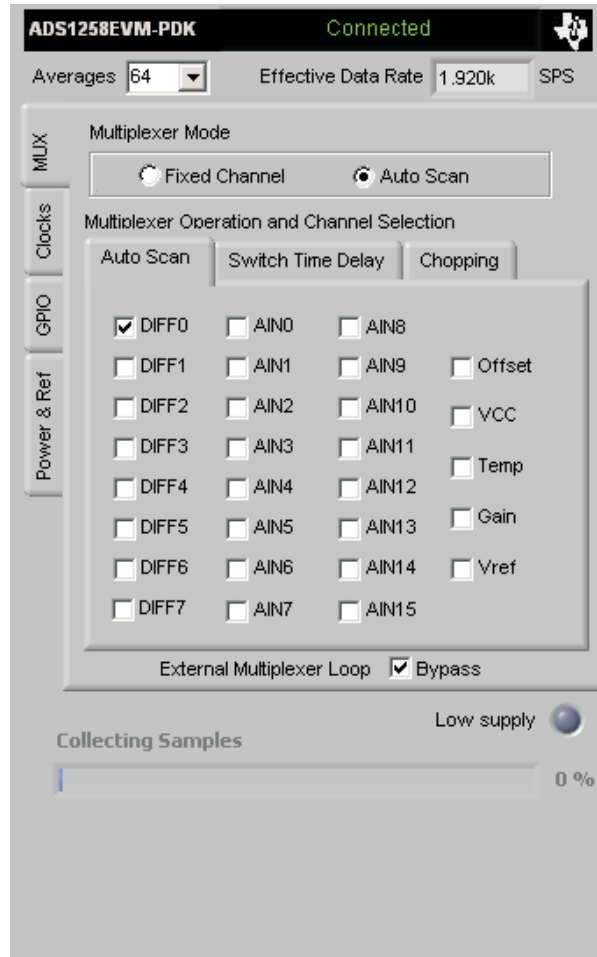

**Figure 22. Mux Settings for Auto Channel Mode**

The ADS1258 switch time delay can be set on the **Switch Time Delay** tab shown in [Figure 23](#). This setting has effect only when in Auto Scan mode. The delay time can be set on this screen, from no delay (0 $\mu$ s) to 384 $\mu$ s.

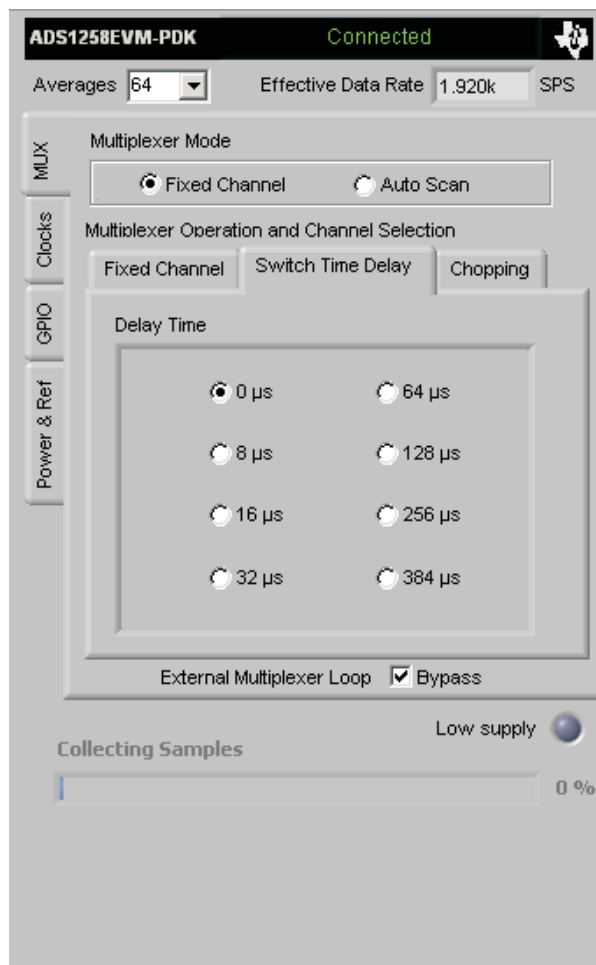

**Figure 23. Switch Delay Settings**

Through the use of the External Chopping mode, the ADS1258 can remove the offset which might be introduced by signal conditioning circuits. It makes two measurements, which means the sampling rate is half as fast. After the first measurement, the polarity is swapped and the second measurement is made. The ADS1258 averages the two readings, canceling the offset as shown in [Figure 24](#).

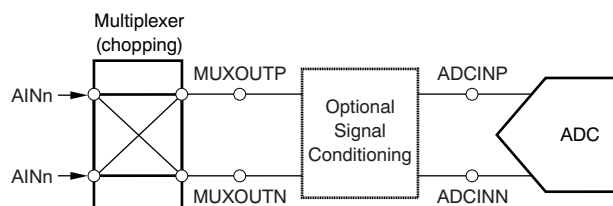

**Figure 24. External Chopping**

This action can be enabled on the **Chopping** tab shown in [Figure 25](#).

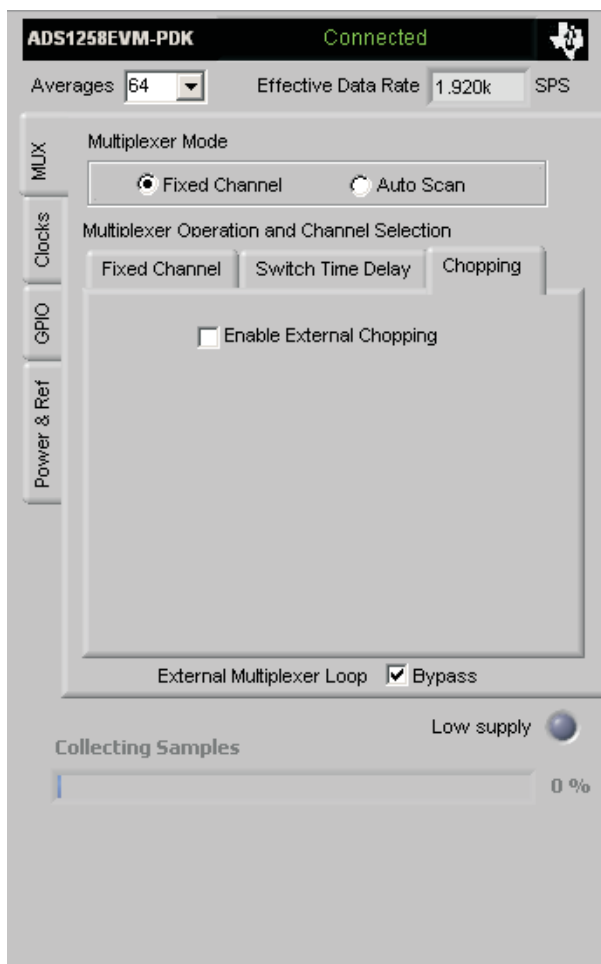
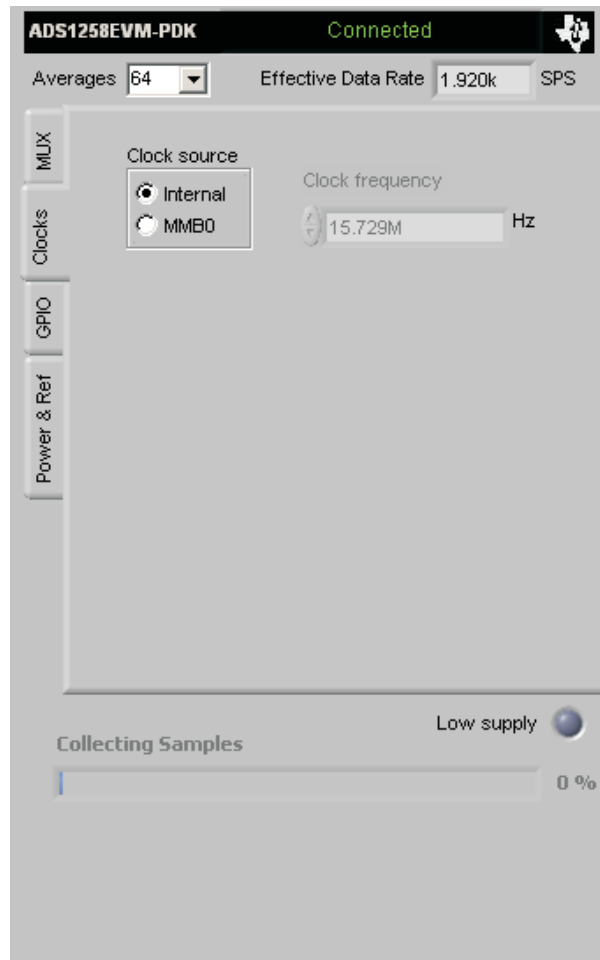

Figure 25. Chopping Settings

### 9.1.2 Clocks Tab

The ADS1258 requires a clock to operate. This clock may be selected on this tab, as shown in [Figure 26](#), using the **Clock Source** controls.



**Figure 26. Clock Settings**

The ADS1258 can operate from a 32kHz crystal, and using an internal PLL, generate a 15.729MHz clock. If the *Internal* setting is selected, this frequency is displayed in the **Clock Frequency** control.

When *MMB0* is selected, a 4MHz to 20MHz clock is supplied to the ADS1258EVM. The default frequency is 16MHz, but it can be adjusted in the **Clock Frequency** control.

### 9.1.3 GPIO Tab

The GPIO Tab (shown in [Figure 27](#)) allows control of the ADS1258 GPIO pins. Down the center of this screen, the **I/O Mode** switches set whether each GPIO pin is an input or an output.

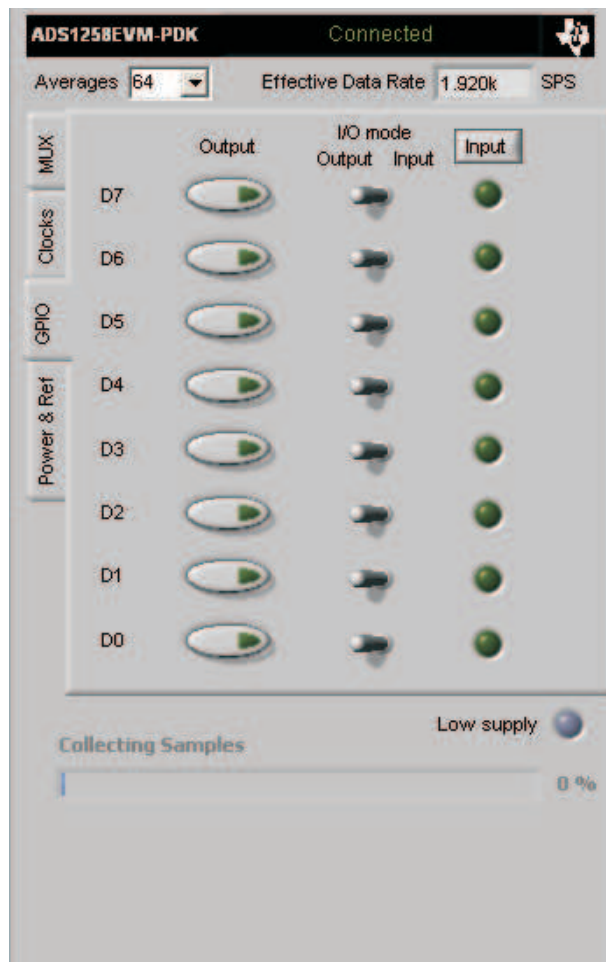

**Figure 27. GPIO Controls**

When selected as outputs, the **Output** buttons set the state of the GPIO pins; when pressed and lit, the pin will be driven high; when unlit, the pin will be driven low.

If selected as inputs, the LED indicators next on the right hand side of the screen will display the state of the pin (lit for HIGH and unlit for LOW). The state of the GPIO pins is sampled only when the **Input** button is pressed—in other words, the display will only update when this pin is pressed.



### 9.1.4 Power and Ref Tab

On this tab (shown in Figure 28), the power-supply mode for the ADS1258 may be selected. As explained earlier, the bipolar mode requires both a +5V and a -5V power supply and the appropriate jumper selections on the MMB0, so bipolar mode cannot be selected here if you are using an ac adaptor. With the appropriate power connections, the **Power supply** can be set to either *Unipolar* or *Bipolar*.

The ADS1258 **Idle mode** can be selected to be either *Standby* (low power, fast startup), or *Sleep* (lowest power).

The **VREF Source** voltage can either come from an *External* voltage or you can choose *DAC* and specify the **VREF** voltage (up to 5V).

When enabled, the Sensor Bias Current Sources (**SBCS**) can be set for either 1.5µA or 24µA.

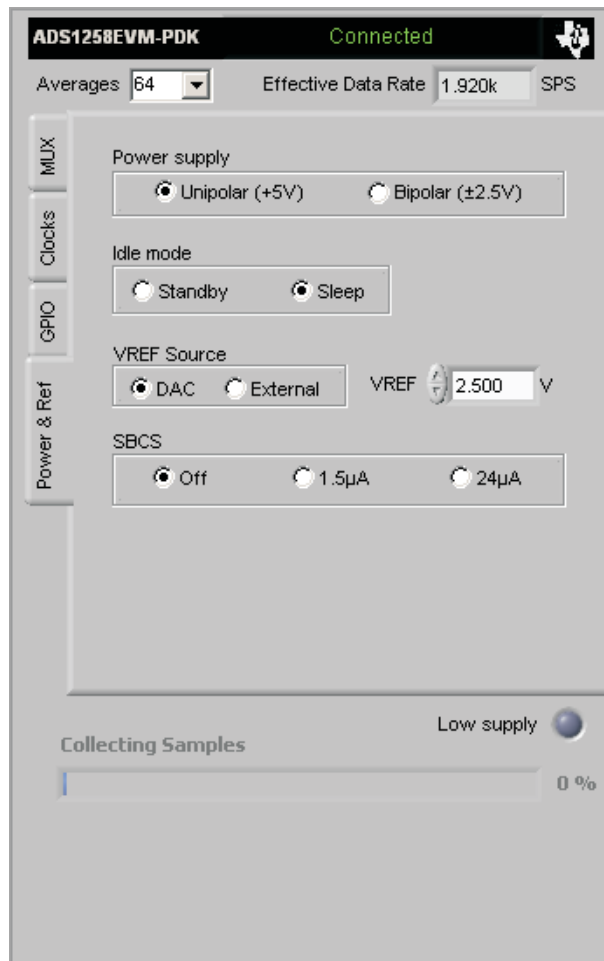
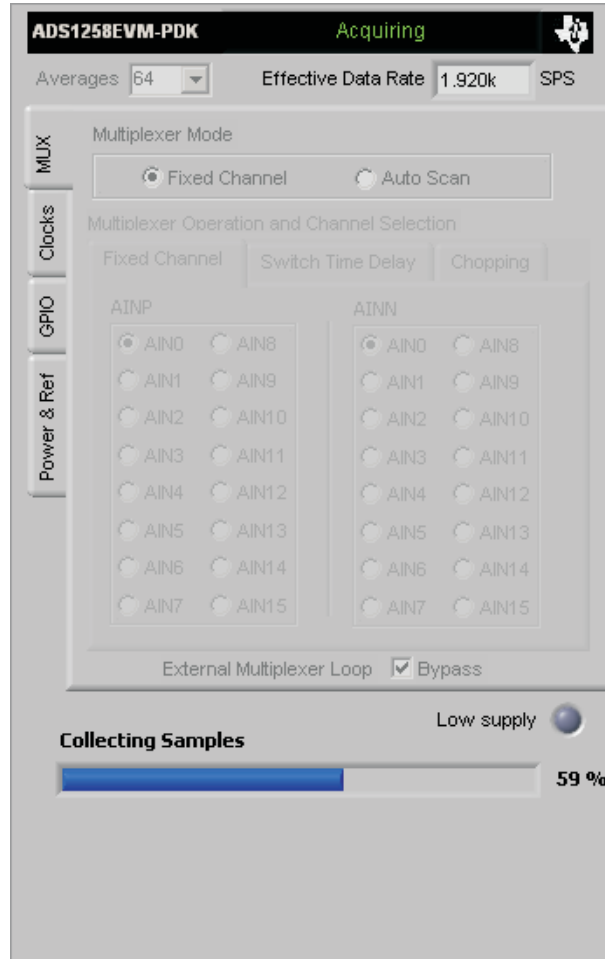

Figure 28. Power and Reference Settings

The **Low Supply** indicator will indicate that the analog supply voltage (AVDD – AVSS) is less than about 4.3V.

### 9.1.5 Collecting Data

Once you have configured the ADS1258 for your test scenario, pressing ADCPro's **Acquire** button will start the collection of the number of data points specified in the Test plug-in *Block Size* control. The ADS1258EVM-PDK plug-in will disable all the front panel controls while acquiring, and display a progress bar as shown in [Figure 29](#).



**Figure 29. Progress Bar While Collecting Data**

For more information on testing ADCs in general and using ADCPro and Test plug-ins, refer to the [ADCPro user guide](#).

### 9.2 Troubleshooting

If ADCPro stops responding while the ADS1258EVM-PDK is connected, try unplugging the power supply from the PDK. Unload and reload the plug-in before reapplying power to the PDK.

## 10 Schematics and Layout

Schematics for the ADS1258EVM are appended to this user's guide. The bill of materials is provided in [Table 9](#).

### 10.1 Bill of Materials

**NOTE:** All components should be RoHS-compliant. Some part numbers may be either leaded or RoHS. Verify that purchased components are RoHS-compliant.

**Table 9. ADS1258EVM Bill of Materials**

Item No.	Qty	Value	Ref Des	Description	Vendor	Part Number
1	2	0	R11, R12	Resistor, Thick Film Chip, 0Ω, 5%, 1/4W, Size = 1206	Panasonic	ERJ-8GEY0R00V
2	1	20	R5	Resistor, Thick Film Chip, 20Ω, 5%, 1/10W, Size = 0603	Panasonic	ERJ-3GEYJ200V
3	2	1k	R3, R4	Resistor, Metal Film Chip, 1kΩ, 0.1%, 1/16W, Size = 0603	Panasonic	ERA-3YEB102V
4	2	10k	R1, R2	Resistor, Thick Film Chip, 10kΩ, 5%, 1/10W, Size = 0603	Panasonic	ERJ-3GEYJ103V
5	7	100k	R6–R10, R13, R14	Resistor, Thick Film Chip, 100kΩ, 5%, 1/10W, Size = 0603	Panasonic	ERJ-3GEYJ104V
6	2	4.7pF	C25, C26	Capacitor, C0G Ceramic, 4.7pF ±5%, 50WV, Size = 0603	TDK	C1608C0G1H047JT
7	1	2200pF	C24	Capacitor, C0G Ceramic, 2200pF ±5%, 630WV, Size = 1206	TDK	C3216C0G2J222JT
8	1	22000pF	C6	Capacitor, X7R Ceramic, 22000pF ±1%, 50WV, Size = 0603	TDK	C1608X7R1H223KT
9	11	0.1μF	C1–C5, C7, C8, C18–C21	Capacitor, X7R Ceramic, 0.1μF ±10%, 50WV, Size = 0603	TDK	C1608X7R1H104KT
10	5	1μF	C12–C16	Capacitor, X7R Ceramic, 1μF ±10%, 16WV, Size = 0603	TDK	C1608X7R1C105KT
11	3	10μF	C9–C11	Capacitor, X5R Ceramic, 10μF ±20%, 16WV, Size = 1206	TDK	C3216X5R1C106MT
12	1	220μF	C17	Chip Capacitor, Low ESR Tantalum 220uF ±10%, 10WV, Size = V	Kemet	T495D227K010ATE125
Not Installed	2		C22, C23	Capacitor, Ceramic, Size = 1206		
13	1		U4	Precision Delta-Sigma ADC, 16 Input, 16-bit or 24-bit	Texas Instruments	ADS1158IRTCTG4 or ADS1258IRTCTG4
14	1		U1	Precision Voltage Reference, 2.5V	Texas Instruments	REF1004I-2.5
15	1		U2	DAC, 16-bit, Low Power	Texas Instruments	DAC8571IDGKG4
16	1		U3	Operational Amplifier	Texas Instruments	OPA301AIDBVRG4
17	1		U5	Buffer, Tri-State, Single Gate	Texas Instruments	SN74LVC1G126DBVRG4
18	1		U6	LDO Voltage Regulator, 2.5V, 100mA	Texas Instruments	TPS79225DBVRG4
19	1		U7	Inverter, Single Gate	Texas Instruments	SN74AHCT1G04DBVR
20	1		U8	Buffer, Open Drain, Single Gate	Texas Instruments	SN74LVC1G07DBVRG4
21	1		U9	LDO Voltage Regulator, 2.5V, 200mA	Texas Instruments	TPS72325DBVTG4
22	1		U11	Dual Split Rail Level Shifter Transceiver	Texas Instruments	SN74AVC2T45DCT
23	1		U12	Bus Transceiver, 8-bit, Level Translator	Texas Instruments	SN74AVC8T245RHLRG4
24	2		J1A, J6A	20-pin SMT Plug	Samtec	TSM-110-01-L-DV-P
25	2		J1B, J6B	20-pin SMT Socket	Samtec	SSW-110-22-F-D-VS-K
26	1		J5A	10-pin SMT Plug	Samtec	TSM-105-01-L-DV-P
27	1		J5B	10-pin SMT Socket	Samtec	SSW-105-22-F-D-VS-K
28	1		J2	Header Strip, 16 pin	Samtec	TSW-108-07-L-D
29	1		J4	Header Strip, 14-pin	Samtec	TSW-107-07-L-D

**Table 9. ADS1258EVM Bill of Materials (continued)**

Item No.	Qty	Value	Ref Des	Description	Vendor	Part Number
30	1		J3	Header Strip, 12-pin	Samtec	TSW-106-07-L-D
31	1		N/A	ADS1258EVM PWB	Texas Instruments	6474410
32	2		D1, D2	Schottky Diode	Fairchild	BAT54
33	1		D3	5.1V, Zener Diode	On Semiconductor	MMBZ5231BLT1G
Not Installed	1		D4	5.1V, Zener Diode	On Semiconductor	MMBZ5231BLT1G
34	2		Q1, Q3	MOSFET, P-Channel, 2.5V	Fairchild Semiconductor	FDN302P
35	1		Q2	Enhancement Mode FET, N-Channel	Fairchild Semiconductor	FDN337N
36	2		S1, S2	Single Pole - Triple Throw Switch	NKK	SS14MDP2
Not Installed	2		TP1, TP2	PCB Test Point, Miniature, Through-Hole	Keystone Electronics	5000
37	1	32.678kHz	X1	Quartz Crystal	Epson Electronics	C-001R 32.7680K-A:PBFFREE
38	10		N/A	Shorting Blocks	Samtec	SNT-100-BK-G-H

### Revision History

NOTE: Page numbers for previous revisions may differ from page numbers in the current version.

#### Changes from C Revision (May, 2011) to D Revision

Page

- Updated software download links in the *Installing the ADCPro Software* section..... 11
- Added *External Wall-Adapter Power-Supply Requirements* section. .... 14

REVISION HISTORY		
REV	ENGINEERING CHANGE NUMBER	APPROVED

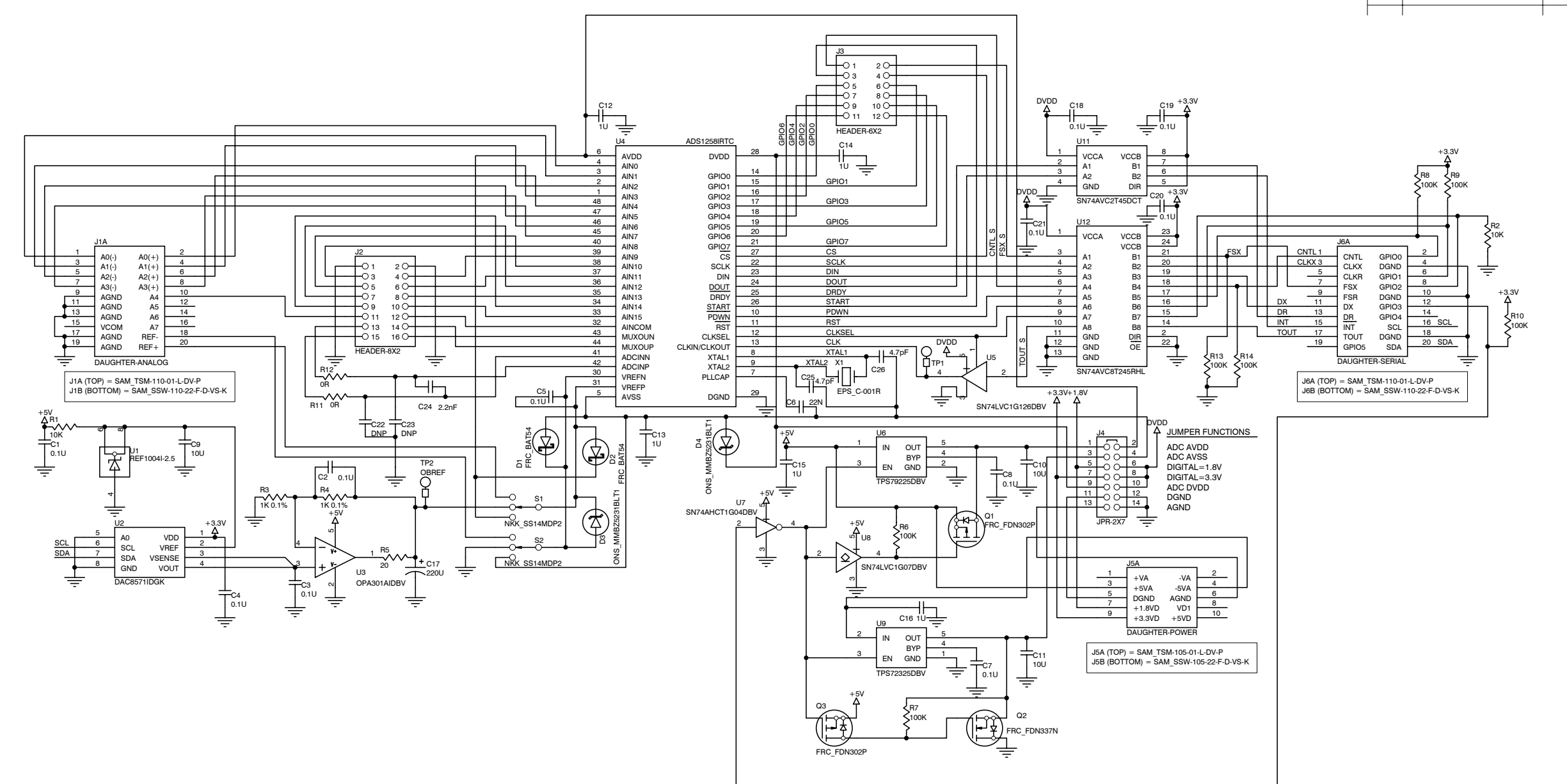

0 = +/- 2.5V  
1 = 0V - 5V

**TEXAS INSTRUMENTS**  
 DATA ACQUISITION PRODUCTS  
 HIGH-PERFORMANCE ANALOG DIVISION  
 SEMICONDUCTOR GROUP  
 8730 SOUTH TUCSON BLVD., TUCSON, AZ 85706 USA

ENGINEER	M. P. ASHTON	TITLE	ADS1258EVM
DRAWN BY	M. P. ASHTON	DOCUMENT CONTROL NO.	6474411
SHEET 1 OF 1	FILE ???	DATE	7 FEB 2006
REV	D	SIZE	B

## STANDARD TERMS AND CONDITIONS FOR EVALUATION MODULES

1. *Delivery:* TI delivers TI evaluation boards, kits, or modules, including any accompanying demonstration software, components, or documentation (collectively, an "EVM" or "EVMs") to the User ("User") in accordance with the terms and conditions set forth herein. Acceptance of the EVM is expressly subject to the following terms and conditions.
  - 1.1 EVMs are intended solely for product or software developers for use in a research and development setting to facilitate feasibility evaluation, experimentation, or scientific analysis of TI semiconductor products. EVMs have no direct function and are not finished products. EVMs shall not be directly or indirectly assembled as a part or subassembly in any finished product. For clarification, any software or software tools provided with the EVM ("Software") shall not be subject to the terms and conditions set forth herein but rather shall be subject to the applicable terms and conditions that accompany such Software
  - 1.2 EVMs are not intended for consumer or household use. EVMs may not be sold, sublicensed, leased, rented, loaned, assigned, or otherwise distributed for commercial purposes by Users, in whole or in part, or used in any finished product or production system.
2. *Limited Warranty and Related Remedies/Disclaimers:*
  - 2.1 These terms and conditions do not apply to Software. The warranty, if any, for Software is covered in the applicable Software License Agreement.
  - 2.2 TI warrants that the TI EVM will conform to TI's published specifications for ninety (90) days after the date TI delivers such EVM to User. Notwithstanding the foregoing, TI shall not be liable for any defects that are caused by neglect, misuse or mistreatment by an entity other than TI, including improper installation or testing, or for any EVMs that have been altered or modified in any way by an entity other than TI. Moreover, TI shall not be liable for any defects that result from User's design, specifications or instructions for such EVMs. Testing and other quality control techniques are used to the extent TI deems necessary or as mandated by government requirements. TI does not test all parameters of each EVM.
  - 2.3 If any EVM fails to conform to the warranty set forth above, TI's sole liability shall be at its option to repair or replace such EVM, or credit User's account for such EVM. TI's liability under this warranty shall be limited to EVMs that are returned during the warranty period to the address designated by TI and that are determined by TI not to conform to such warranty. If TI elects to repair or replace such EVM, TI shall have a reasonable time to repair such EVM or provide replacements. Repaired EVMs shall be warranted for the remainder of the original warranty period. Replaced EVMs shall be warranted for a new full ninety (90) day warranty period.
3. *Regulatory Notices:*
  - 3.1 *United States*
    - 3.1.1 *Notice applicable to EVMs not FCC-Approved:*

This kit is designed to allow product developers to evaluate electronic components, circuitry, or software associated with the kit to determine whether to incorporate such items in a finished product and software developers to write software applications for use with the end product. This kit is not a finished product and when assembled may not be resold or otherwise marketed unless all required FCC equipment authorizations are first obtained. Operation is subject to the condition that this product not cause harmful interference to licensed radio stations and that this product accept harmful interference. Unless the assembled kit is designed to operate under part 15, part 18 or part 95 of this chapter, the operator of the kit must operate under the authority of an FCC license holder or must secure an experimental authorization under part 5 of this chapter.
    - 3.1.2 *For EVMs annotated as FCC – FEDERAL COMMUNICATIONS COMMISSION Part 15 Compliant:*

### CAUTION

This device complies with part 15 of the FCC Rules. Operation is subject to the following two conditions: (1) This device may not cause harmful interference, and (2) this device must accept any interference received, including interference that may cause undesired operation.

Changes or modifications not expressly approved by the party responsible for compliance could void the user's authority to operate the equipment.

### FCC Interference Statement for Class A EVM devices

*NOTE: This equipment has been tested and found to comply with the limits for a Class A digital device, pursuant to part 15 of the FCC Rules. These limits are designed to provide reasonable protection against harmful interference when the equipment is operated in a commercial environment. This equipment generates, uses, and can radiate radio frequency energy and, if not installed and used in accordance with the instruction manual, may cause harmful interference to radio communications. Operation of this equipment in a residential area is likely to cause harmful interference in which case the user will be required to correct the interference at his own expense.*

## FCC Interference Statement for Class B EVM devices

*NOTE: This equipment has been tested and found to comply with the limits for a Class B digital device, pursuant to part 15 of the FCC Rules. These limits are designed to provide reasonable protection against harmful interference in a residential installation. This equipment generates, uses and can radiate radio frequency energy and, if not installed and used in accordance with the instructions, may cause harmful interference to radio communications. However, there is no guarantee that interference will not occur in a particular installation. If this equipment does cause harmful interference to radio or television reception, which can be determined by turning the equipment off and on, the user is encouraged to try to correct the interference by one or more of the following measures:*

- Reorient or relocate the receiving antenna.
- Increase the separation between the equipment and receiver.
- Connect the equipment into an outlet on a circuit different from that to which the receiver is connected.
- Consult the dealer or an experienced radio/TV technician for help.

### 3.2 Canada

3.2.1 For EVMs issued with an Industry Canada Certificate of Conformance to RSS-210

#### Concerning EVMs Including Radio Transmitters:

This device complies with Industry Canada license-exempt RSS standard(s). Operation is subject to the following two conditions: (1) this device may not cause interference, and (2) this device must accept any interference, including interference that may cause undesired operation of the device.

#### Concernant les EVMs avec appareils radio:

Le présent appareil est conforme aux CNR d'Industrie Canada applicables aux appareils radio exempts de licence. L'exploitation est autorisée aux deux conditions suivantes: (1) l'appareil ne doit pas produire de brouillage, et (2) l'utilisateur de l'appareil doit accepter tout brouillage radioélectrique subi, même si le brouillage est susceptible d'en compromettre le fonctionnement.

#### Concerning EVMs Including Detachable Antennas:

Under Industry Canada regulations, this radio transmitter may only operate using an antenna of a type and maximum (or lesser) gain approved for the transmitter by Industry Canada. To reduce potential radio interference to other users, the antenna type and its gain should be so chosen that the equivalent isotropically radiated power (e.i.r.p.) is not more than that necessary for successful communication. This radio transmitter has been approved by Industry Canada to operate with the antenna types listed in the user guide with the maximum permissible gain and required antenna impedance for each antenna type indicated. Antenna types not included in this list, having a gain greater than the maximum gain indicated for that type, are strictly prohibited for use with this device.

#### Concernant les EVMs avec antennes détachables

Conformément à la réglementation d'Industrie Canada, le présent émetteur radio peut fonctionner avec une antenne d'un type et d'un gain maximal (ou inférieur) approuvé pour l'émetteur par Industrie Canada. Dans le but de réduire les risques de brouillage radioélectrique à l'intention des autres utilisateurs, il faut choisir le type d'antenne et son gain de sorte que la puissance isotrope rayonnée équivalente (p.i.r.e.) ne dépasse pas l'intensité nécessaire à l'établissement d'une communication satisfaisante. Le présent émetteur radio a été approuvé par Industrie Canada pour fonctionner avec les types d'antenne énumérés dans le manuel d'usage et ayant un gain admissible maximal et l'impédance requise pour chaque type d'antenne. Les types d'antenne non inclus dans cette liste, ou dont le gain est supérieur au gain maximal indiqué, sont strictement interdits pour l'exploitation de l'émetteur.

### 3.3 Japan

3.3.1 *Notice for EVMs delivered in Japan:* Please see [http://www.tij.co.jp/lstds/ti\\_ja/general/eStore/notice\\_01.page](http://www.tij.co.jp/lstds/ti_ja/general/eStore/notice_01.page) 日本国内に輸入される評価用キット、ボードについては、次のところをご覧ください。  
[http://www.tij.co.jp/lstds/ti\\_ja/general/eStore/notice\\_01.page](http://www.tij.co.jp/lstds/ti_ja/general/eStore/notice_01.page)

3.3.2 *Notice for Users of EVMs Considered "Radio Frequency Products" in Japan:* EVMs entering Japan may not be certified by TI as conforming to Technical Regulations of Radio Law of Japan.

If User uses EVMs in Japan, not certified to Technical Regulations of Radio Law of Japan, User is required by Radio Law of Japan to follow the instructions below with respect to EVMs:

1. Use EVMs in a shielded room or any other test facility as defined in the notification #173 issued by Ministry of Internal Affairs and Communications on March 28, 2006, based on Sub-section 1.1 of Article 6 of the Ministry's Rule for Enforcement of Radio Law of Japan,
2. Use EVMs only after User obtains the license of Test Radio Station as provided in Radio Law of Japan with respect to EVMs, or
3. Use of EVMs only after User obtains the Technical Regulations Conformity Certification as provided in Radio Law of Japan with respect to EVMs. Also, do not transfer EVMs, unless User gives the same notice above to the transferee. Please note that if User does not follow the instructions above, User will be subject to penalties of Radio Law of Japan.

【無線電波を送信する製品の開発キットをお使いになる際の注意事項】 開発キットの中には技術基準適合証明を受けていないものがあります。技術適合証明を受けていないものご使用に際しては、電波法遵守のため、以下のいずれかの措置を取っていただく必要がありますのでご注意ください。

1. 電波法施行規則第6条第1項第1号に基づく平成18年3月28日総務省告示第173号で定められた電波暗室等の試験設備でご使用いただく。
2. 実験局の免許を取得後ご使用いただく。
3. 技術基準適合証明を取得後ご使用いただく。

なお、本製品は、上記の「ご使用にあたっての注意」を譲渡先、移転先に通知しない限り、譲渡、移転できないものとします。

上記を遵守頂けない場合は、電波法の罰則が適用される可能性があることをご留意ください。日本テキサス・インスツルメンツ株式会社  
東京都新宿区西新宿 6 丁目 2 4 番 1 号  
西新宿三井ビル

3.3.3 *Notice for EVMs for Power Line Communication:* Please see [http://www.tij.co.jp/llds/ti\\_ja/general/eStore/notice\\_02.page](http://www.tij.co.jp/llds/ti_ja/general/eStore/notice_02.page)  
電力線搬送波通信についての開発キットをお使いになる際の注意事項については、次のところをご覧ください。[http://www.tij.co.jp/llds/ti\\_ja/general/eStore/notice\\_02.page](http://www.tij.co.jp/llds/ti_ja/general/eStore/notice_02.page)

#### 4 *EVM Use Restrictions and Warnings:*

- 4.1 EVMS ARE NOT FOR USE IN FUNCTIONAL SAFETY AND/OR SAFETY CRITICAL EVALUATIONS, INCLUDING BUT NOT LIMITED TO EVALUATIONS OF LIFE SUPPORT APPLICATIONS.
- 4.2 User must read and apply the user guide and other available documentation provided by TI regarding the EVM prior to handling or using the EVM, including without limitation any warning or restriction notices. The notices contain important safety information related to, for example, temperatures and voltages.
- 4.3 *Safety-Related Warnings and Restrictions:*
  - 4.3.1 User shall operate the EVM within TI's recommended specifications and environmental considerations stated in the user guide, other available documentation provided by TI, and any other applicable requirements and employ reasonable and customary safeguards. Exceeding the specified performance ratings and specifications (including but not limited to input and output voltage, current, power, and environmental ranges) for the EVM may cause personal injury or death, or property damage. If there are questions concerning performance ratings and specifications, User should contact a TI field representative prior to connecting interface electronics including input power and intended loads. Any loads applied outside of the specified output range may also result in unintended and/or inaccurate operation and/or possible permanent damage to the EVM and/or interface electronics. Please consult the EVM user guide prior to connecting any load to the EVM output. If there is uncertainty as to the load specification, please contact a TI field representative. During normal operation, even with the inputs and outputs kept within the specified allowable ranges, some circuit components may have elevated case temperatures. These components include but are not limited to linear regulators, switching transistors, pass transistors, current sense resistors, and heat sinks, which can be identified using the information in the associated documentation. When working with the EVM, please be aware that the EVM may become very warm.
  - 4.3.2 EVMs are intended solely for use by technically qualified, professional electronics experts who are familiar with the dangers and application risks associated with handling electrical mechanical components, systems, and subsystems. User assumes all responsibility and liability for proper and safe handling and use of the EVM by User or its employees, affiliates, contractors or designees. User assumes all responsibility and liability to ensure that any interfaces (electronic and/or mechanical) between the EVM and any human body are designed with suitable isolation and means to safely limit accessible leakage currents to minimize the risk of electrical shock hazard. User assumes all responsibility and liability for any improper or unsafe handling or use of the EVM by User or its employees, affiliates, contractors or designees.
- 4.4 User assumes all responsibility and liability to determine whether the EVM is subject to any applicable international, federal, state, or local laws and regulations related to User's handling and use of the EVM and, if applicable, User assumes all responsibility and liability for compliance in all respects with such laws and regulations. User assumes all responsibility and liability for proper disposal and recycling of the EVM consistent with all applicable international, federal, state, and local requirements.

5. *Accuracy of Information:* To the extent TI provides information on the availability and function of EVMs, TI attempts to be as accurate as possible. However, TI does not warrant the accuracy of EVM descriptions, EVM availability or other information on its websites as accurate, complete, reliable, current, or error-free.



6. *Disclaimers:*

6.1 EXCEPT AS SET FORTH ABOVE, EVMS AND ANY WRITTEN DESIGN MATERIALS PROVIDED WITH THE EVM (AND THE DESIGN OF THE EVM ITSELF) ARE PROVIDED "AS IS" AND "WITH ALL FAULTS." TI DISCLAIMS ALL OTHER WARRANTIES, EXPRESS OR IMPLIED, REGARDING SUCH ITEMS, INCLUDING BUT NOT LIMITED TO ANY IMPLIED WARRANTIES OF MERCHANTABILITY OR FITNESS FOR A PARTICULAR PURPOSE OR NON-INFRINGEMENT OF ANY THIRD PARTY PATENTS, COPYRIGHTS, TRADE SECRETS OR OTHER INTELLECTUAL PROPERTY RIGHTS.

6.2 EXCEPT FOR THE LIMITED RIGHT TO USE THE EVM SET FORTH HEREIN, NOTHING IN THESE TERMS AND CONDITIONS SHALL BE CONSTRUED AS GRANTING OR CONFERRING ANY RIGHTS BY LICENSE, PATENT, OR ANY OTHER INDUSTRIAL OR INTELLECTUAL PROPERTY RIGHT OF TI, ITS SUPPLIERS/LICENSORS OR ANY OTHER THIRD PARTY, TO USE THE EVM IN ANY FINISHED END-USER OR READY-TO-USE FINAL PRODUCT, OR FOR ANY INVENTION, DISCOVERY OR IMPROVEMENT MADE, CONCEIVED OR ACQUIRED PRIOR TO OR AFTER DELIVERY OF THE EVM.

7. *USER'S INDEMNITY OBLIGATIONS AND REPRESENTATIONS.* USER WILL DEFEND, INDEMNIFY AND HOLD TI, ITS LICENSORS AND THEIR REPRESENTATIVES HARMLESS FROM AND AGAINST ANY AND ALL CLAIMS, DAMAGES, LOSSES, EXPENSES, COSTS AND LIABILITIES (COLLECTIVELY, "CLAIMS") ARISING OUT OF OR IN CONNECTION WITH ANY HANDLING OR USE OF THE EVM THAT IS NOT IN ACCORDANCE WITH THESE TERMS AND CONDITIONS. THIS OBLIGATION SHALL APPLY WHETHER CLAIMS ARISE UNDER STATUTE, REGULATION, OR THE LAW OF TORT, CONTRACT OR ANY OTHER LEGAL THEORY, AND EVEN IF THE EVM FAILS TO PERFORM AS DESCRIBED OR EXPECTED.

8. *Limitations on Damages and Liability:*

8.1 *General Limitations.* IN NO EVENT SHALL TI BE LIABLE FOR ANY SPECIAL, COLLATERAL, INDIRECT, PUNITIVE, INCIDENTAL, CONSEQUENTIAL, OR EXEMPLARY DAMAGES IN CONNECTION WITH OR ARISING OUT OF THESE TERMS AND CONDITIONS OR THE USE OF THE EVMS PROVIDED HEREUNDER, REGARDLESS OF WHETHER TI HAS BEEN ADVISED OF THE POSSIBILITY OF SUCH DAMAGES. EXCLUDED DAMAGES INCLUDE, BUT ARE NOT LIMITED TO, COST OF REMOVAL OR REINSTALLATION, ANCILLARY COSTS TO THE PROCUREMENT OF SUBSTITUTE GOODS OR SERVICES, RETESTING, OUTSIDE COMPUTER TIME, LABOR COSTS, LOSS OF GOODWILL, LOSS OF PROFITS, LOSS OF SAVINGS, LOSS OF USE, LOSS OF DATA, OR BUSINESS INTERRUPTION. NO CLAIM, SUIT OR ACTION SHALL BE BROUGHT AGAINST TI MORE THAN ONE YEAR AFTER THE RELATED CAUSE OF ACTION HAS OCCURRED.

8.2 *Specific Limitations.* IN NO EVENT SHALL TI'S AGGREGATE LIABILITY FROM ANY WARRANTY OR OTHER OBLIGATION ARISING OUT OF OR IN CONNECTION WITH THESE TERMS AND CONDITIONS, OR ANY USE OF ANY TI EVM PROVIDED HEREUNDER, EXCEED THE TOTAL AMOUNT PAID TO TI FOR THE PARTICULAR UNITS SOLD UNDER THESE TERMS AND CONDITIONS WITH RESPECT TO WHICH LOSSES OR DAMAGES ARE CLAIMED. THE EXISTENCE OF MORE THAN ONE CLAIM AGAINST THE PARTICULAR UNITS SOLD TO USER UNDER THESE TERMS AND CONDITIONS SHALL NOT ENLARGE OR EXTEND THIS LIMIT.

9. *Return Policy.* Except as otherwise provided, TI does not offer any refunds, returns, or exchanges. Furthermore, no return of EVM(s) will be accepted if the package has been opened and no return of the EVM(s) will be accepted if they are damaged or otherwise not in a resalable condition. If User feels it has been incorrectly charged for the EVM(s) it ordered or that delivery violates the applicable order, User should contact TI. All refunds will be made in full within thirty (30) working days from the return of the components(s), excluding any postage or packaging costs.

10. *Governing Law:* These terms and conditions shall be governed by and interpreted in accordance with the laws of the State of Texas, without reference to conflict-of-laws principles. User agrees that non-exclusive jurisdiction for any dispute arising out of or relating to these terms and conditions lies within courts located in the State of Texas and consents to venue in Dallas County, Texas. Notwithstanding the foregoing, any judgment may be enforced in any United States or foreign court, and TI may seek injunctive relief in any United States or foreign court.

## IMPORTANT NOTICE

Texas Instruments Incorporated and its subsidiaries (TI) reserve the right to make corrections, enhancements, improvements and other changes to its semiconductor products and services per JESD46, latest issue, and to discontinue any product or service per JESD48, latest issue. Buyers should obtain the latest relevant information before placing orders and should verify that such information is current and complete. All semiconductor products (also referred to herein as "components") are sold subject to TI's terms and conditions of sale supplied at the time of order acknowledgment.

TI warrants performance of its components to the specifications applicable at the time of sale, in accordance with the warranty in TI's terms and conditions of sale of semiconductor products. Testing and other quality control techniques are used to the extent TI deems necessary to support this warranty. Except where mandated by applicable law, testing of all parameters of each component is not necessarily performed.

TI assumes no liability for applications assistance or the design of Buyers' products. Buyers are responsible for their products and applications using TI components. To minimize the risks associated with Buyers' products and applications, Buyers should provide adequate design and operating safeguards.

TI does not warrant or represent that any license, either express or implied, is granted under any patent right, copyright, mask work right, or other intellectual property right relating to any combination, machine, or process in which TI components or services are used. Information published by TI regarding third-party products or services does not constitute a license to use such products or services or a warranty or endorsement thereof. Use of such information may require a license from a third party under the patents or other intellectual property of the third party, or a license from TI under the patents or other intellectual property of TI.

Reproduction of significant portions of TI information in TI data books or data sheets is permissible only if reproduction is without alteration and is accompanied by all associated warranties, conditions, limitations, and notices. TI is not responsible or liable for such altered documentation. Information of third parties may be subject to additional restrictions.

Resale of TI components or services with statements different from or beyond the parameters stated by TI for that component or service voids all express and any implied warranties for the associated TI component or service and is an unfair and deceptive business practice. TI is not responsible or liable for any such statements.

Buyer acknowledges and agrees that it is solely responsible for compliance with all legal, regulatory and safety-related requirements concerning its products, and any use of TI components in its applications, notwithstanding any applications-related information or support that may be provided by TI. Buyer represents and agrees that it has all the necessary expertise to create and implement safeguards which anticipate dangerous consequences of failures, monitor failures and their consequences, lessen the likelihood of failures that might cause harm and take appropriate remedial actions. Buyer will fully indemnify TI and its representatives against any damages arising out of the use of any TI components in safety-critical applications.

In some cases, TI components may be promoted specifically to facilitate safety-related applications. With such components, TI's goal is to help enable customers to design and create their own end-product solutions that meet applicable functional safety standards and requirements. Nonetheless, such components are subject to these terms.

No TI components are authorized for use in FDA Class III (or similar life-critical medical equipment) unless authorized officers of the parties have executed a special agreement specifically governing such use.

Only those TI components which TI has specifically designated as military grade or "enhanced plastic" are designed and intended for use in military/aerospace applications or environments. Buyer acknowledges and agrees that any military or aerospace use of TI components which have **not** been so designated is solely at the Buyer's risk, and that Buyer is solely responsible for compliance with all legal and regulatory requirements in connection with such use.

TI has specifically designated certain components as meeting ISO/TS16949 requirements, mainly for automotive use. In any case of use of non-designated products, TI will not be responsible for any failure to meet ISO/TS16949.

### Products

Audio	<a href="http://www.ti.com/audio">www.ti.com/audio</a>
Amplifiers	<a href="http://amplifier.ti.com">amplifier.ti.com</a>
Data Converters	<a href="http://dataconverter.ti.com">dataconverter.ti.com</a>
DLP® Products	<a href="http://www.dlp.com">www.dlp.com</a>
DSP	<a href="http://dsp.ti.com">dsp.ti.com</a>
Clocks and Timers	<a href="http://www.ti.com/clocks">www.ti.com/clocks</a>
Interface	<a href="http://interface.ti.com">interface.ti.com</a>
Logic	<a href="http://logic.ti.com">logic.ti.com</a>
Power Mgmt	<a href="http://power.ti.com">power.ti.com</a>
Microcontrollers	<a href="http://microcontroller.ti.com">microcontroller.ti.com</a>
RFID	<a href="http://www.ti-rfid.com">www.ti-rfid.com</a>
OMAP Applications Processors	<a href="http://www.ti.com/omap">www.ti.com/omap</a>
Wireless Connectivity	<a href="http://www.ti.com/wirelessconnectivity">www.ti.com/wirelessconnectivity</a>

### Applications

Automotive and Transportation	<a href="http://www.ti.com/automotive">www.ti.com/automotive</a>
Communications and Telecom	<a href="http://www.ti.com/communications">www.ti.com/communications</a>
Computers and Peripherals	<a href="http://www.ti.com/computers">www.ti.com/computers</a>
Consumer Electronics	<a href="http://www.ti.com/consumer-apps">www.ti.com/consumer-apps</a>
Energy and Lighting	<a href="http://www.ti.com/energy">www.ti.com/energy</a>
Industrial	<a href="http://www.ti.com/industrial">www.ti.com/industrial</a>
Medical	<a href="http://www.ti.com/medical">www.ti.com/medical</a>
Security	<a href="http://www.ti.com/security">www.ti.com/security</a>
Space, Avionics and Defense	<a href="http://www.ti.com/space-avionics-defense">www.ti.com/space-avionics-defense</a>
Video and Imaging	<a href="http://www.ti.com/video">www.ti.com/video</a>

### TI E2E Community

[e2e.ti.com](http://e2e.ti.com)