

May.1.2023 Copyright 2023 HIROSE ELECTRIC CO., LTD. All Rights Reserved.
 In case of consideration for using Automotive equipment / device which demand high reliability, kindly contact our sales window correspondents.

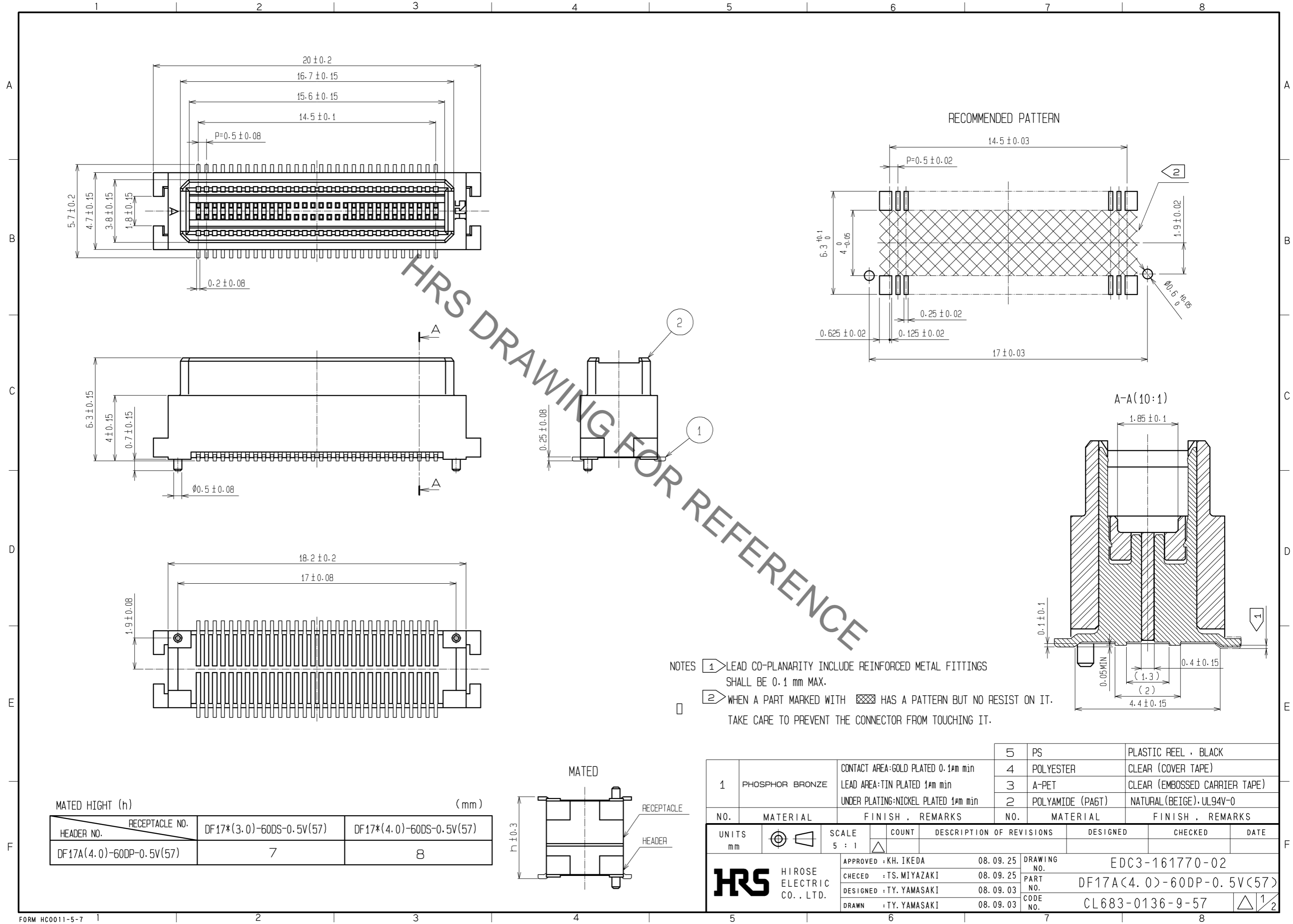

HRS DRAWING FOR REFERENCE

- NOTES
- ① LEAD CO-PLANARITY INCLUDE REINFORCED METAL FITTINGS SHALL BE 0.1 mm MAX.
 - ② WHEN A PART MARKED WITH HAS A PATTERN BUT NO RESIST ON IT. TAKE CARE TO PREVENT THE CONNECTOR FROM TOUCHING IT.

MATED HIGHT (h)		(mm)	
HEADER NO.	RECEPTACLE NO.	DF17*(3.0)-60DS-0.5V(57)	DF17*(4.0)-60DS-0.5V(57)
DF17A(4.0)-60DP-0.5V(57)		7	8

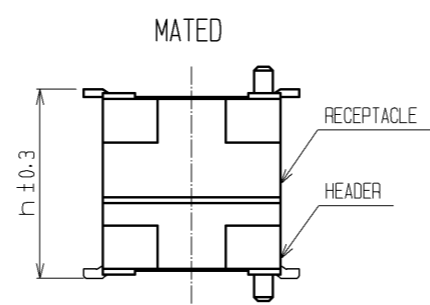

1	PHOSPHOR BRONZE	CONTACT AREA:GOLD PLATED 0.1μm min LEAD AREA:TIN PLATED 1μm min UNDER PLATING:NICKEL PLATED 1μm min	5 PS 4 POLYESTER 3 A-PET 2 POLYAMIDE (PA6T)	PLASTIC REEL · BLACK CLEAR (COVER TAPE) CLEAR (EMBOSSED CARRIER TAPE) NATURAL (BEIGE) · UL94V-0			
NO.	MATERIAL	FINISH . REMARKS	NO.	MATERIAL	FINISH . REMARKS		
UNITS mm		SCALE 5 : 1	COUNT 	DESCRIPTION OF REVISIONS	DESIGNED	CHECKED	DATE
HRS HIROSE ELECTRIC CO., LTD.		APPROVED : KH. IKEDA 08.09.25	DRAWING NO. EDC3-161770-02				
		CHECED : TS. MIYAZAKI 08.09.25	PART NO. DF17A(4.0)-60DP-0.5V(57)				
		DESIGNED : TY. YAMASAKI 08.09.03	CODE NO. CL683-0136-9-57				
		DRAWN : TY. YAMASAKI 08.09.03	DATE 1/2				

May.1.2023 Copyright 2023 HIROSE ELECTRIC CO., LTD. All Rights Reserved.
 In case of consideration for using Automotive equipment / device which demand high reliability, kindly contact our sales window correspondents.

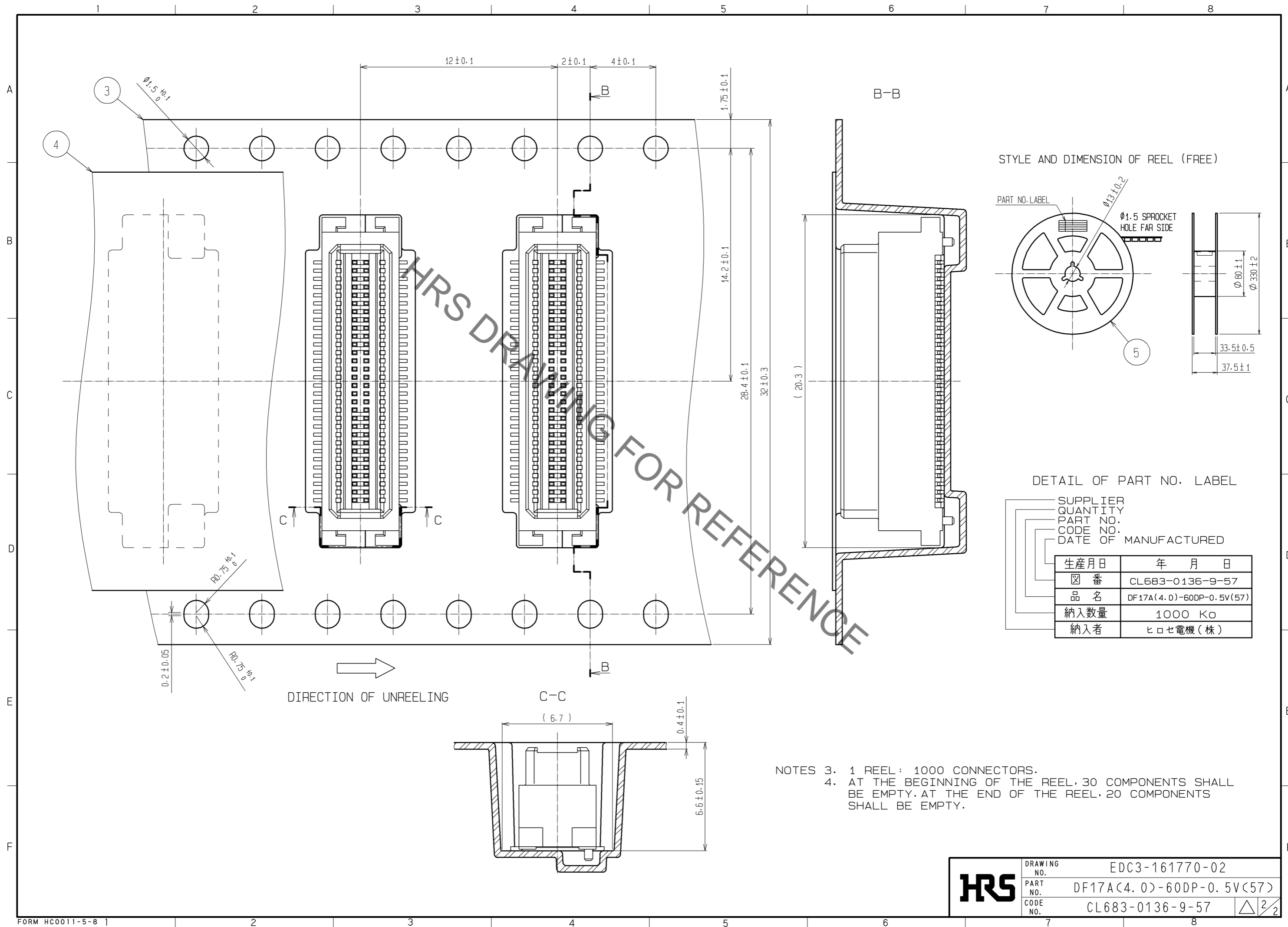

STYLE AND DIMENSION OF REEL (FREE)

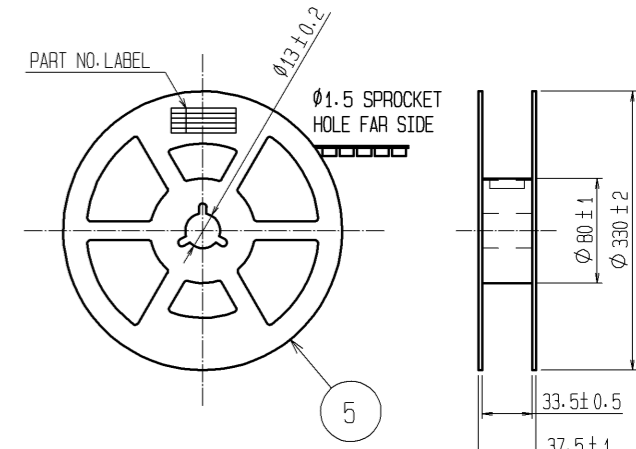

DETAIL OF PART NO. LABEL

SUPPLIER	生産月日	年 月 日
QUANTITY	☒ 番	CL683-0136-9-57
PART NO.	品 名	DF17A(4.0)-60DP-0.5V(57)
CODE NO.	納入数量	1000 K ϕ
DATE OF MANUFACTURED	納入者	ヒロセ電機(株)

- NOTES 3. 1 REEL : 1000 CONNECTORS.
 4. AT THE BEGINNING OF THE REEL, 30 COMPONENTS SHALL BE EMPTY. AT THE END OF THE REEL, 20 COMPONENTS SHALL BE EMPTY.

HRS	DRAWING NO.	EDC3-161770-02
	PART NO.	DF17A(4.0)-60DP-0.5V(57)
	CODE NO.	CL683-0136-9-57
		\triangle 2/2