

AB-EZDC (DC IC series) datasheet

Constant Current regulator

Features

- 1.3-18V Wide input voltage
- 0.3-1V output dropout voltage
- DFN packages
- Support power supply PWM dimming
- Accurate constant current ($I_s \pm 3\%$)
- Over temperature protection (current ramp down during 120-160°C T_J)
- -40~85° operating ambient temperature

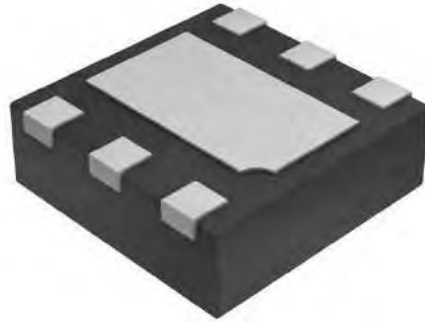

Description

AB-EZDC is a constant current LED driver with the adjustable current. It is designed to maintain constant current and hence constant luminance for DC powered LED lighting applications. Additionally, to ensure system reliability, AB-EZDC is built with thermal protection function (OTP) and offers the adjustable current by an external sense resistor. (current limited by heat dissipation of IC package and heat sink)

*The information in this document is subject to change without American Bright Optoelectronics Corp. notice.

Pin Description

Top View



Pin	Function
VDD	Power source
OPT	Current sink
GND	Ground
REXT	Current setting resistor

Ideal IV characteristic

$V_{MODE} = V_{OPT}$ (cascade mode)

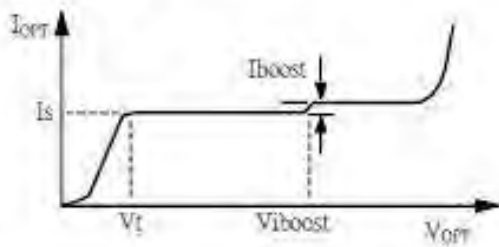

$V_{MODE} = GND$ or Floating

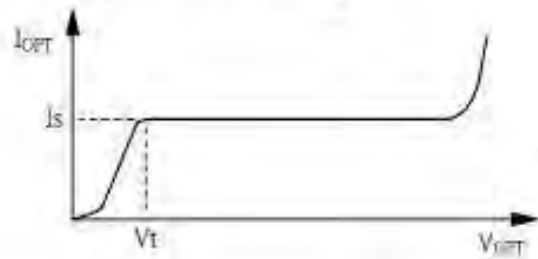

Mode	Mode Pin	Current boost	Leakage (Max.)
Cascade mode	$V_{MODE} = V_{OPT}$	+5%~+11%* I_{OPT}	55uA
Normal mode	$V_{MODE} = GND / Floating$	-	0.5uA

Recommended Operating Conditions

Characteristic	Symbol	Condition	Min.	Typ.	Max.	Unit
Supply voltage	V_{DD}		1.6	-	18	V
Working voltage	V_{OPT}	$I_{PN}=I_S$	1.6	-	15	V
Rext output voltage	V_{REXT}	Bond wire effect exclusive	0.152	0.16	0.168	V
Output current	I_S	Spec.	-	-	150	mA
Output current skew	I_{Skew}	I_S	-	-	5	%
Line/Load regulation	$\%/V_{OPT}$	$9V > V_{OPT} > 1.6V$	-	-	± 1	%/V

Absolute Maximum Ratings

Parameter	Symbol	Rating	Unit
Supply voltage	V_{DDmax}	-0.2~20	V
Output voltage	V_{OPTmax}	-0.2~16	V
Output current	I_{OPTmax}	200	mA
Reverse voltage (V_N to V_P/V_{DD})	V_R	0.5	V
Operating temperature	T_{OPR}	-40~+85	$^{\circ}C$
Storage temperature	T_{STG}	-55~+150	$^{\circ}C$

Thermal Protection

Output current will decrease to lower down the power dissipation on chip as junction temperature more than thermal protection temperature ($\sim 125^{\circ}C$); output current will almost shut down as junction temperature reach $160^{\circ}C$

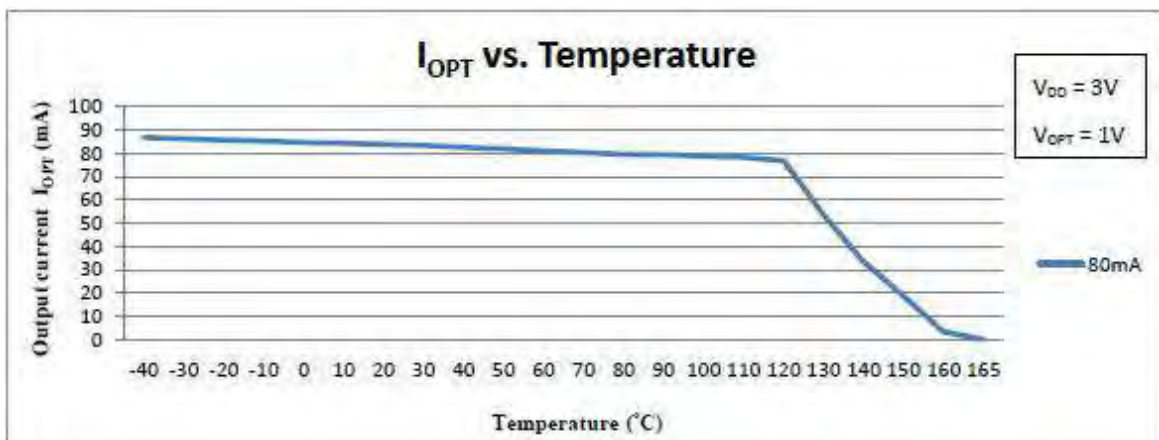

Application note

The current can be modulated via exterior resistor at R_{EXT} . The current range is during 20mA to 200mA.

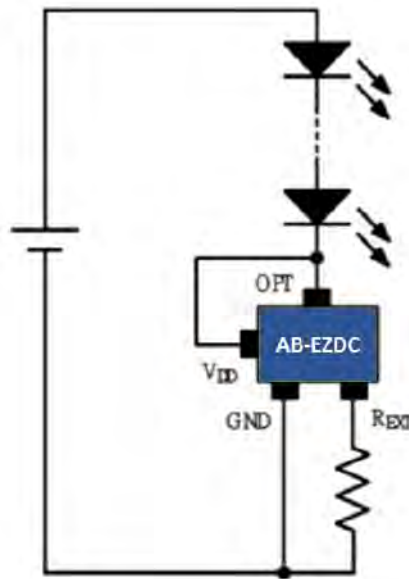
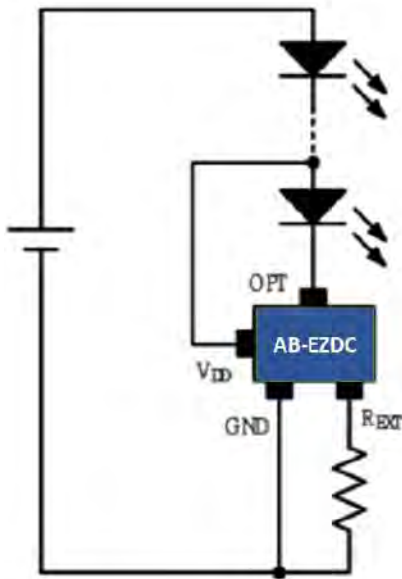

Output current:

$$I_{OPT} = \frac{0.16}{R_{EXT} + R_{GW}}$$

R_{GW} = bond wire R of R_{EXT} pin
($0.1\Omega \sim 0.2\Omega$ typically)

Package Information

Dual Flat No-Lead (DFN) packages is lead-less, near Chip Scale Packages (CSP) with a low profile, moderate thermal dissipation for high power application, and good electrical performance. DFN is a surface mount plastic package with leads located at the bottom of the package, with the DFN having leads on two sides of the package versus on four sides for the QFN.

The dimension of currently available package is 2.0 x 2.0 x 0.75 mm. The electrical lead pitch is 0.65mm; six electrical pads exposed area are all 0.3 x 0.35 mm; central thermal pad exposed is 1.0 x 1.6 mm. (For AB-EZPD series only)

