

May.1.2023 Copyright 2023 HIROSE ELECTRIC CO., LTD. All Rights Reserved.
In case of consideration for using Automotive equipment / device which demand high reliability, kindly contact our sales window correspondents.

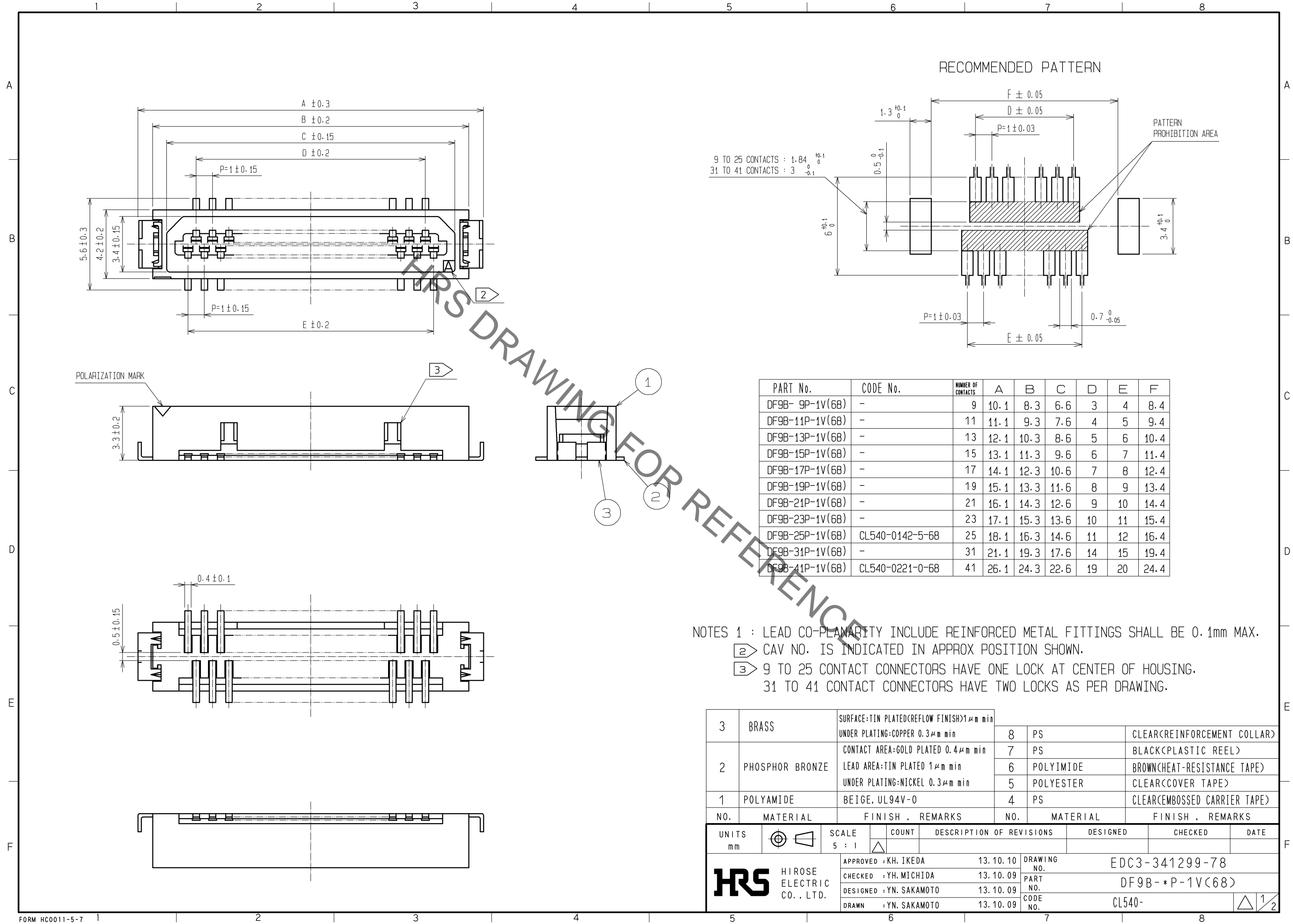

9 TO 25 CONTACTS : 1.84 ± 0.1
31 TO 41 CONTACTS : 3 ± 0.1

RECOMMENDED PATTERN

PART No.	CODE No.	NUMBER OF CONTACTS	A	B	C	D	E	F
DF9B- 9P-1V(68)	-	9	10.1	8.3	6.6	3	4	8.4
DF9B-11P-1V(68)	-	11	11.1	9.3	7.6	4	5	9.4
DF9B-13P-1V(68)	-	13	12.1	10.3	8.6	5	6	10.4
DF9B-15P-1V(68)	-	15	13.1	11.3	9.6	6	7	11.4
DF9B-17P-1V(68)	-	17	14.1	12.3	10.6	7	8	12.4
DF9B-19P-1V(68)	-	19	15.1	13.3	11.6	8	9	13.4
DF9B-21P-1V(68)	-	21	16.1	14.3	12.6	9	10	14.4
DF9B-23P-1V(68)	-	23	17.1	15.3	13.6	10	11	15.4
DF9B-25P-1V(68)	CL540-0142-5-68	25	18.1	16.3	14.6	11	12	16.4
DF9B-31P-1V(68)	-	31	21.1	19.3	17.6	14	15	19.4
DF9B-41P-1V(68)	CL540-0221-0-68	41	26.1	24.3	22.6	19	20	24.4

NOTES 1 : LEAD CO-PLANARITY INCLUDE REINFORCED METAL FITTINGS SHALL BE 0.1mm MAX.
 ② CAV NO. IS INDICATED IN APPROX POSITION SHOWN.
 ③ 9 TO 25 CONTACT CONNECTORS HAVE ONE LOCK AT CENTER OF HOUSING.
 31 TO 41 CONTACT CONNECTORS HAVE TWO LOCKS AS PER DRAWING.

NO.	MATERIAL	FINISH . REMARKS	NO.	MATERIAL	FINISH . REMARKS
3	BRASS	SURFACE:TIN PLATED(REFLOW FINISH)1μm min UNDER PLATING:COPPER 0.3μm min	8	PS	CLEAR(REINFORCEMENT COLLAR)
2	PHOSPHOR BRONZE	CONTACT AREA:GOLD PLATED 0.4μm min LEAD AREA:TIN PLATED 1μm min UNDER PLATING:NICKEL 0.3μm min	7	PS	BLACK(PLASTIC REEL)
			6	POLYIMIDE	BROWN(HEAT-RESISTANCE TAPE)
1	POLYAMIDE	BEIGE, UL94V-0	5	POLYESTER	CLEAR(COVER TAPE)
			4	PS	CLEAR(EMBOSSED CARRIER TAPE)

UNITS	SCALE	COUNT	DESCRIPTION OF REVISIONS	DESIGNED	CHECKED	DATE
mm	5 : 1	△				

APPROVED : KH. IKEDA	13.10.10	DRAWING NO.	EDC3-341299-78
CHECKED : YH. MICHIDA	13.10.09	PART NO.	DF9B- *P-1V(68)
DESIGNED : YN. SAKAMOTO	13.10.09	CODE NO.	CL540-
DRAWN : YN. SAKAMOTO	13.10.09		

May.1.2023 Copyright 2023 HIROSE ELECTRIC CO., LTD. All Rights Reserved.
In case of consideration for using Automotive equipment / device which demand high reliability, kindly contact our sales window correspondents.

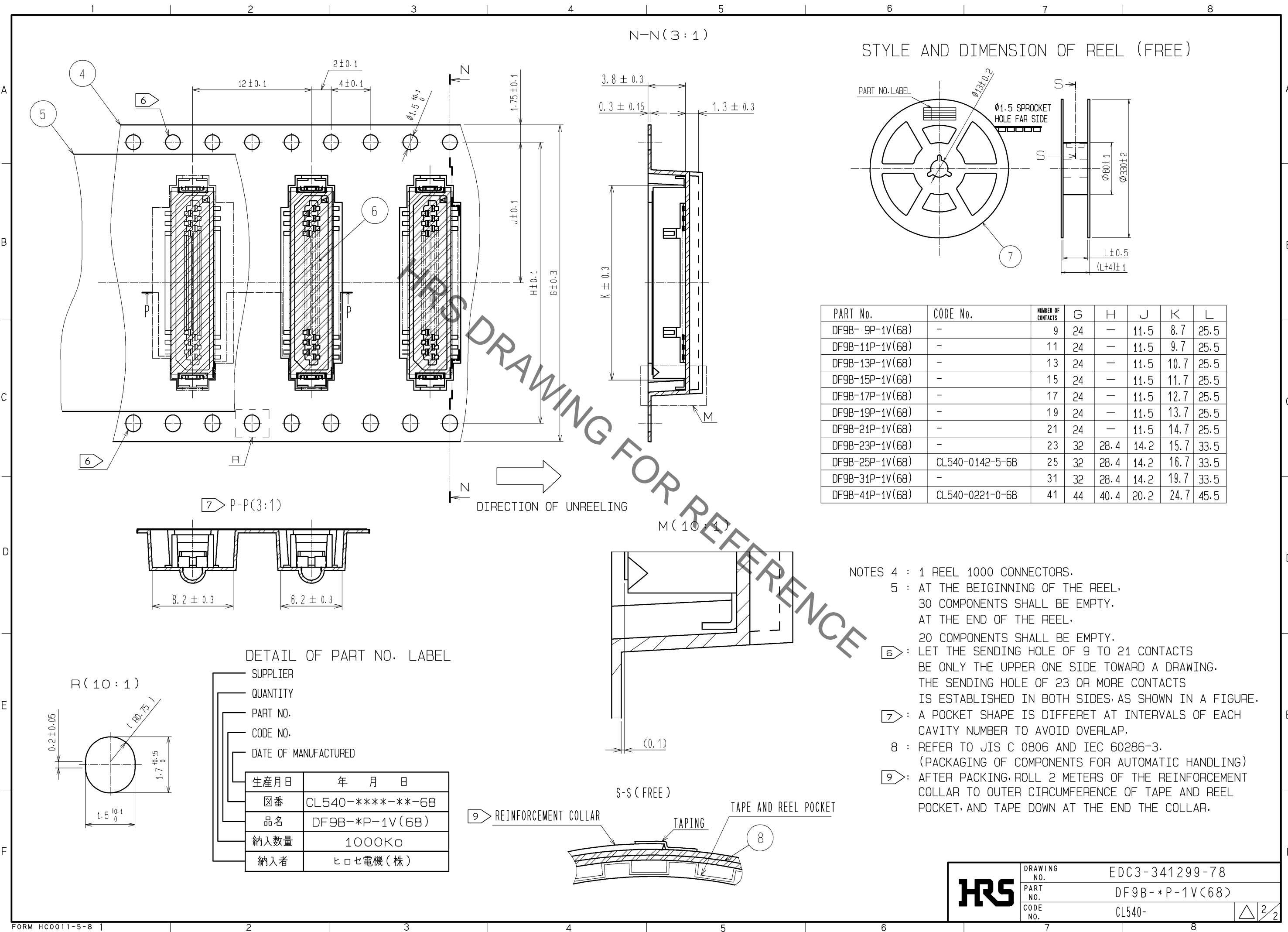

STYLE AND DIMENSION OF REEL (FREE)

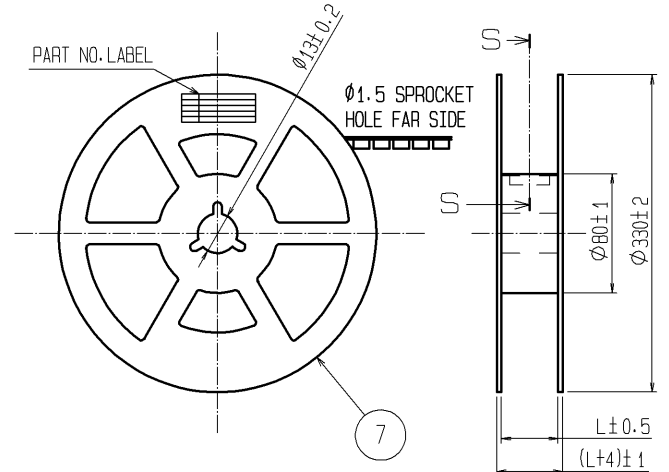

PART No.	CODE No.	NUMBER OF CONTACTS	G	H	J	K	L
DF9B-9P-1V(68)	-	9	24	-	11.5	8.7	25.5
DF9B-11P-1V(68)	-	11	24	-	11.5	9.7	25.5
DF9B-13P-1V(68)	-	13	24	-	11.5	10.7	25.5
DF9B-15P-1V(68)	-	15	24	-	11.5	11.7	25.5
DF9B-17P-1V(68)	-	17	24	-	11.5	12.7	25.5
DF9B-19P-1V(68)	-	19	24	-	11.5	13.7	25.5
DF9B-21P-1V(68)	-	21	24	-	11.5	14.7	25.5
DF9B-23P-1V(68)	-	23	32	28.4	14.2	15.7	33.5
DF9B-25P-1V(68)	CL540-0142-5-68	25	32	28.4	14.2	16.7	33.5
DF9B-31P-1V(68)	-	31	32	28.4	14.2	19.7	33.5
DF9B-41P-1V(68)	CL540-0221-0-68	41	44	40.4	20.2	24.7	45.5

- NOTES
- 4 : 1 REEL 1000 CONNECTORS.
 - 5 : AT THE BEIGINNING OF THE REEL, 30 COMPONENTS SHALL BE EMPTY. AT THE END OF THE REEL, 20 COMPONENTS SHALL BE EMPTY.
 - 6 : LET THE SENDING HOLE OF 9 TO 21 CONTACTS BE ONLY THE UPPER ONE SIDE TOWARD A DRAWING. THE SENDING HOLE OF 23 OR MORE CONTACTS IS ESTABLISHED IN BOTH SIDES, AS SHOWN IN A FIGURE.
 - 7 : A POCKET SHAPE IS DIFFERET AT INTERVALS OF EACH CAVITY NUMBER TO AVOID OVERLAP.
 - 8 : REFER TO JIS C 0806 AND IEC 60286-3. (PACKAGING OF COMPONENTS FOR AUTOMATIC HANDLING)
 - 9 : AFTER PACKING, ROLL 2 METERS OF THE REINFORCEMENT COLLAR TO OUTER CIRCUMFERENCE OF TAPE AND REEL POCKET, AND TAPE DOWN AT THE END THE COLLAR.

DETAIL OF PART NO. LABEL

SUPPLIER

QUANTITY

PART NO.

CODE NO.

DATE OF MANUFACTURED

生産月日	年 月 日
図番	CL540-****-**-68
品名	DF9B-*P-1V(68)
納入数量	1000K□
納入者	ヒロセ電機(株)

HRS	DRAWING NO.	EDC3-341299-78
	PART NO.	DF9B-*P-1V(68)
	CODE NO.	CL540-