

RSL10 Evaluation and Development Board User's Manual

EVBUM2529/D

INTRODUCTION

Purpose

This manual provides detailed information about the configuration and use of the RSL10 Evaluation and Development Board (RSL10-002GEVB). The Evaluation and Development Board is designed to be used with the software development tools to evaluate the performance and capabilities of the RSL10 radio System-on-Chip (SoC).

Manual Organization

The *Evaluation and Development Board Manual* contains the following chapters and appendices:

- **Chapter 1: Introduction** describes the purpose of this manual, describes the target reader, explains how the book is organized, and provides a list of suggested reading for more information.
- **Chapter 2: Overview** provides an overview of the Evaluation and Development Board described in this manual.
- **Chapter 3: Evaluation and Development Board** provides the details of the Evaluation and Development Board. The chapter is divided into the following topics:
 - ◆ Development Board Setup
 - ◆ Development Board Design
 - ◆ Power Supply
 - ◆ Level Translators
 - ◆ LED Circuitry
 - ◆ RSL10 SoC
 - ◆ Measuring the Current Consumption
 - ◆ SWJ-DP Debug Port
 - ◆ Digital Input/Output (DIO)
 - ◆ Power Supply and Test Points
- **Appendix A: Connectors** provides a complete list of the connectors and jumpers on the Evaluation and Development Board.
- **Appendix B: Schematics** contains the schematics for the Evaluation and Development Board.
- **Appendix C: Bill of Materials** contains a list of the parts that are used to manufacture the Evaluation and Development Board.

Further Reading

For more information, refer to the following documents:

- *Getting Started with RSL10*
- *RSL10 Firmware Reference*
- *RSL10 Hardware Reference*
- RSL10 Datasheet

OVERVIEW

Introduction

The RSL10 Evaluation and Development Board is used for evaluating the RSL10 SoC and for application development. The board provides access to all input and output connections via 0.1" standard headers. The on-board communication interface circuit provides communication to the board from a host PC. The communication interface translates RSL10 SWJ-DP debug port signals to the USB of the host PC. There is also an on-board 4-bit level shifter for debugging; it translates the I/O signal level of RSL10 to the 3.3 V digital logic level. It is not enabled by default; you enable it when it is needed.

Evaluation and Development Board Features

The Evaluation and Development Board enables developers to evaluate the performance and capabilities of the RSL10 radio SoC in addition to developing, demonstrating and debugging applications.

Key features of the board include:

- J-Link onboard solution provides a SWJ-DP (serial-wire and/or JTAG) interface that enables you to debug the board via a USB connection with the PC
- Alternate onboard SWJ-DP (serial-wire and/or JTAG) interface for Arm[®] Cortex[®]-M3 processor debugging
- Access to all RSL10 peripherals via standard 0.1" headers
- Onboard 4-bit level translator to translate the LPDSP32 debug interface at low voltage to a 3.3 V JTAG debugger
- Antenna matching and filtering network
- Integrated PCB antenna
- Compliance with the Arduino form factor
- Support for PMOD (i.e., J4 is a standard connector)

EVALUATION AND DEVELOPMENT BOARD

Evaluation and Development Board Setup

This section is an overview of how to configure the Evaluation and Development Board. Details of the

development board configuration are discussed later in this manual.

Figure 1 represents an overview of the board setup.

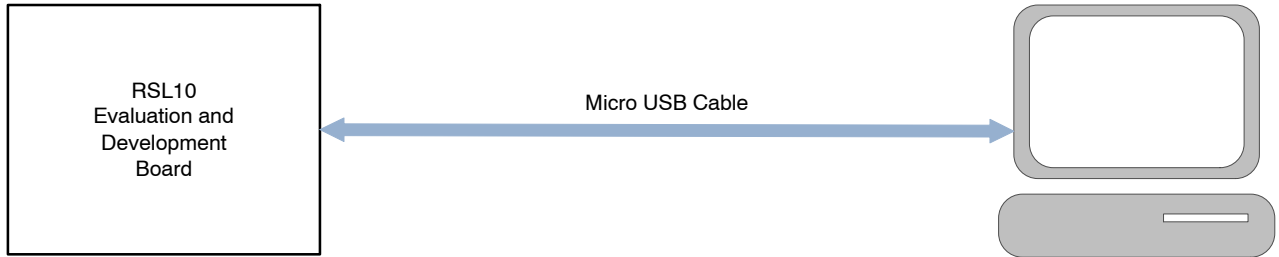

Figure 1. Evaluation and Development Board Setup

If you want to use an external J-Link debugger instead of the onboard one, connect the debugger to connector P2 on

the QFN board, as shown in Figure 2. Notice that for this setup, you also need a power supply.

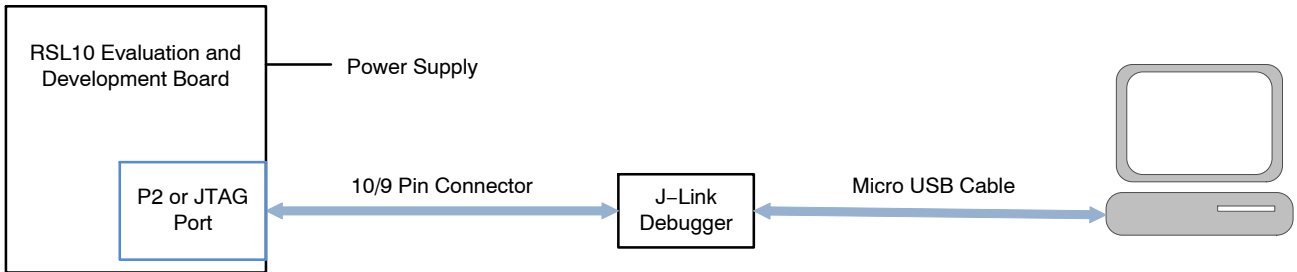

Figure 2. Evaluation and Development Board Setup with External J-Link Debugger

Evaluation and Development Board Design

The following sections detail the various sub-circuits of the RSL10 Evaluation and Development Board. The block

diagram in Figure 3 shows the locations of the various circuit sections. Figure 5 and Figure 6 provide 3-dimensional illustrations of the QFN board.

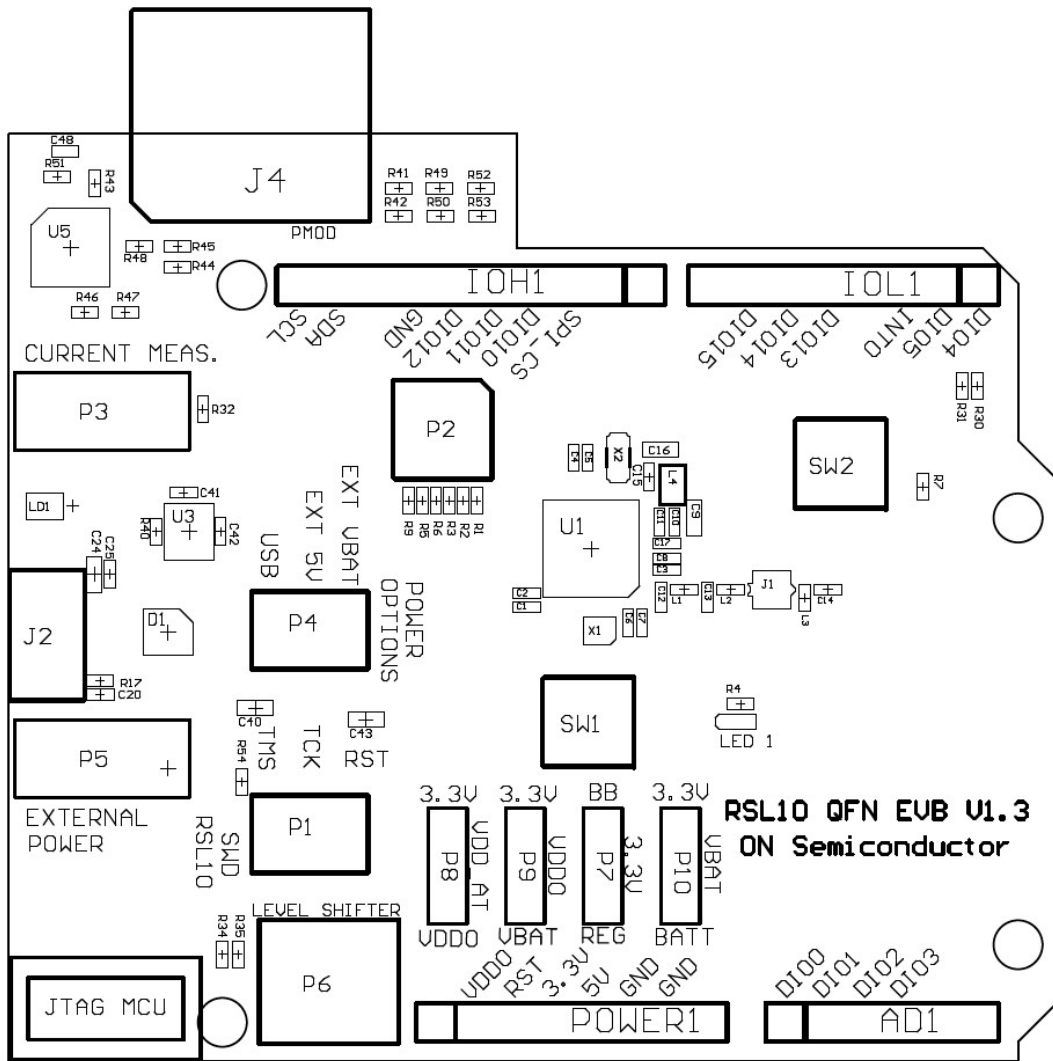

Figure 3. Circuit Location Block Diagram (Top View)

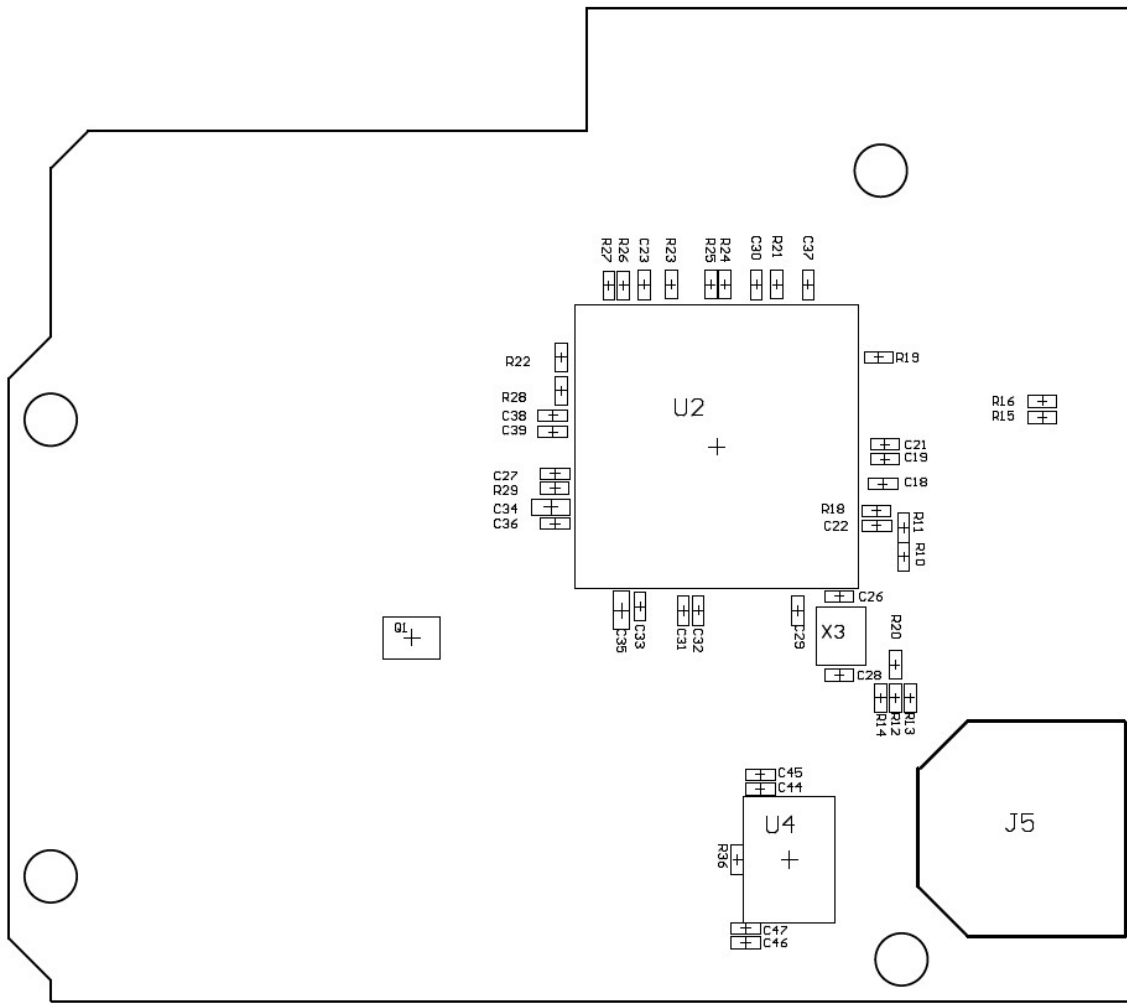

Figure 4. Circuit Location Block Diagram (Bottom View)

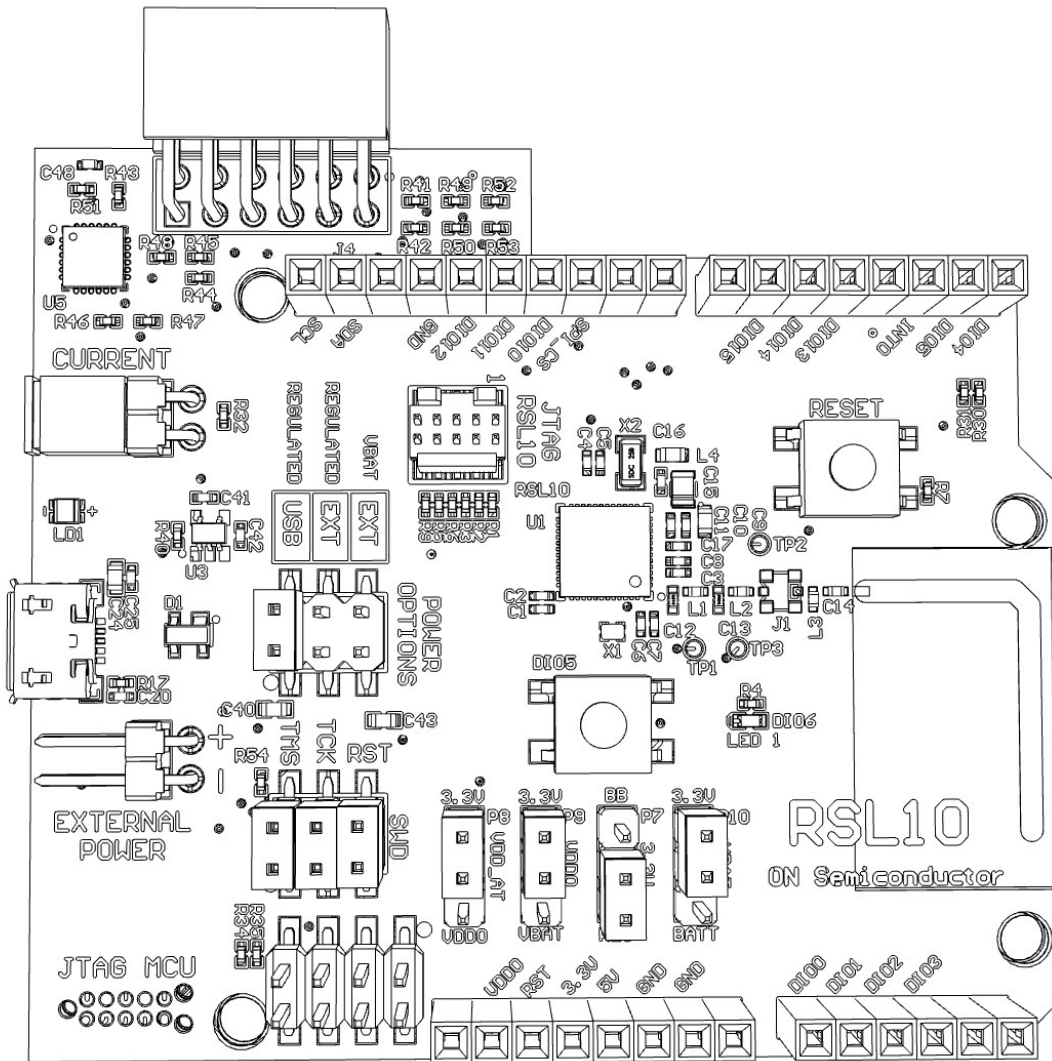

Figure 5. Three-Dimensional Line Drawing of the Board (Top View)

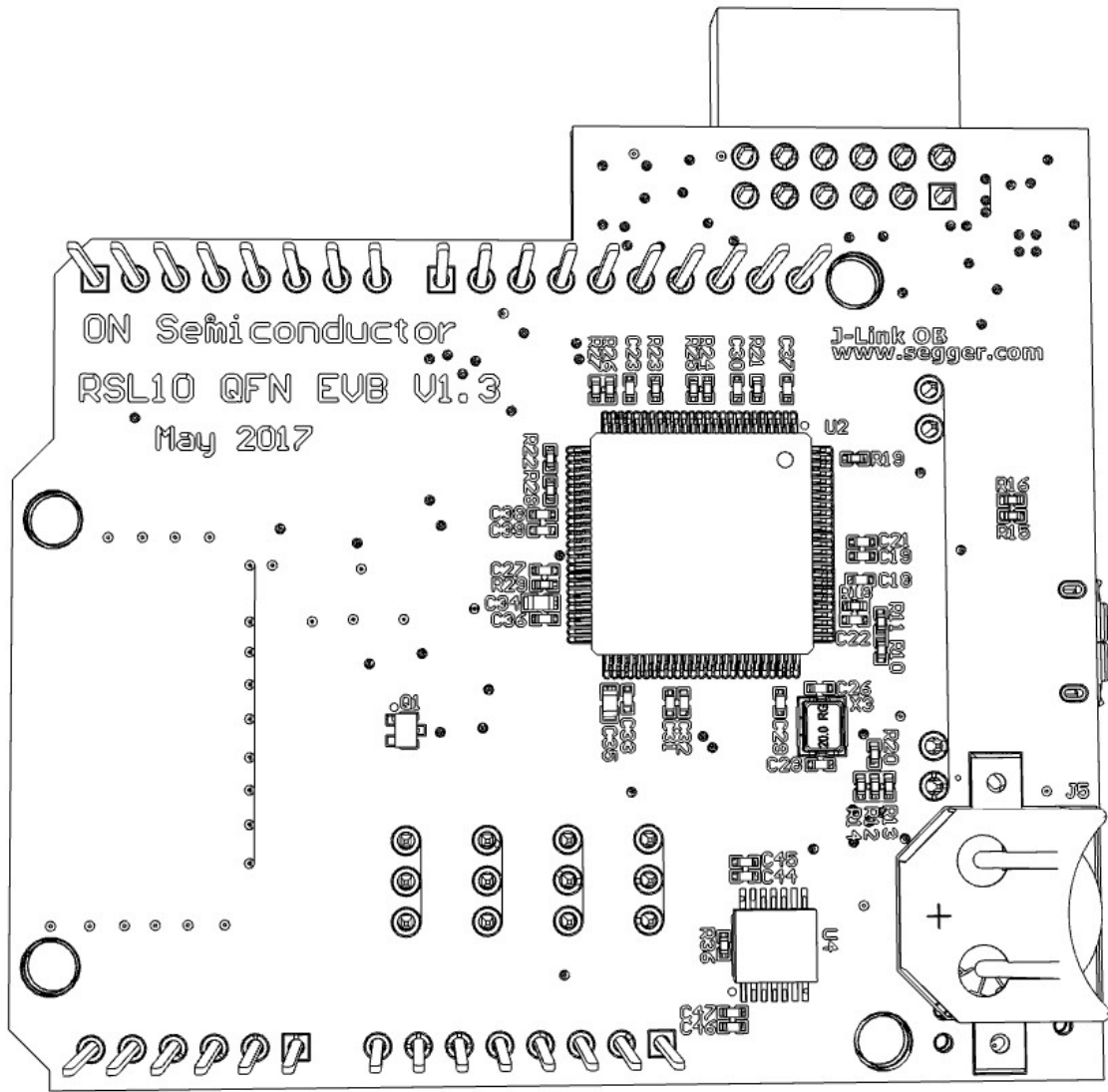

Figure 6. Three-Dimensional Line Drawing of the Board (Bottom View)

Power Supply

The Evaluation and Development Board can be powered by one of the following:

- Micro USB port with regulator
- External power supply connector (P5) with regulator

- External power supply connector (P5) without regulator

Use the jumpers on pin headers P4, P7 and P10 to select a power supply option as show in Table 1.

Table 1. POWER SUPPLY SELECTION

Power Source	Jumper Position on P4	Jumper Position on P7	Jumper Position on P10
Micro USB Port with Regulator	1&2	2&3	1&2
External Power Supply with Regulator	3&4	2&3	1&2
External Power Supply without Regulator	5&6	2&3	2&3

Table 2. MINIMUM/MAXIMUM EXTERNAL REGULATED VOLTAGES

Power Supply	Header	Input Voltage		
		Minimum	Typical	Maximum
RSL10 and J-Link OB MCU	EXT-PSU Regulated	3.3 V	3.6 V	5.0 V
RSL10 and J-Link OB MCU	USB	-	5.0 V	-
RSL10	EXT-PSU Unregulated	1.1 V	1.25 V	3.6 V

Level Translators

The board has level translators for the DIO signals of RSL10, including the clock signal. The level translators facilitate interfacing to external devices that operate at a higher voltage than RSL10.

VDDO and 3.3 V are two different power rails. The translator allows a logic signal on the VDDO side to be translated to either a higher or a lower logic signal voltage on the 3.3 V side, and vice-versa.

The level translation circuitry consists of components U4 and the 2x4 header. Signals are translated from the VDDO voltage reference to 3.3 V (default) voltage provided by the regulator output or by an external supply. The VDDO voltage is configured by the pin on header P11 (located on the board edge) to either VBAT_DUT, 3.3 V or other level within the VDDO voltage range, which is 1.1 to 3.3 V.

The NLSX5014 level translators are bi-directional. They have the following features:

- Wide voltage operating range: 0.9 V to 4.5 V
- VDDO and 3.3 V are independent
- VDDO can be equal to, or less than, 3.3 V when connected to the power rail

To enable the level translators, populate positions R34 and R35 with 0 ohms. By default, the level translators are disabled. NOTE: Enabling the level translator affects power consumption.

LED Circuitry

There are two LEDs on the board. One is a dual color LED, called LD1, connected to the J-Link emulator

microcontroller unit (MCU). The other is the green LED, connected to DIO 6 of RSL10. You can use this LED within your applications as an indication LED by programming DIO 6. If DIO 6 is high, this LED is on.

Measuring the Current Consumption

This section deals with measuring current consumption for the Evaluation and Development Board.

Headers are provided for each of the regulated voltages for additional capacitance and/or for measurements. RSL10 has 16 digital I/Os. The VDDO pin in header P9 configures the I/O voltages for power domains to VBAT. The VBAT pin in header P10 configures the VBAT source. The power select pin in header P4 configures the power source of the RSL10. In addition the measurements should be done by connecting an ammeter to current measure header P3 to measure the device power consumption in isolation.

To measure the current consumption of RSL10 only, you need to source the chip using the external power supply without the regulator as shown in Table 2. To remove leakage currents during current measurement, remove the jumpers on header SWD. Removing the jumpers between the MCU and RSL10 that connect nRESET, SWDIO and SWCLK prevents current leakage from the JTAG interface, avoiding inaccurate current measurements. In addition, DIOs 4, 5 and 6 must be configured to High-Z (disabled) with no pull up in software. DIOs 4 and 5 are directly connected to the Atmel chip and will leak power into it. DIO 6 is directly connected to the transistor driving the LED and can leak power into it.

SWJ–DP DEBUG Port

The J–Link adapters are typically used to communicate with RSL10 using the standard Coresight SWJ–DP debug port in a JTAG/SW communication protocol. The 9-pin 0.05 in Samtec FTSH header (P1), defined by the Arm Cortex–M3 core on the board, connects RSL10 to external adapters compatible with the Arm Cortex–M3 processor’s SWJ–DP interface. Alternatively, you can connect the micro USB port on the board to a PC.

DIGITAL Input/Output (DIO)

RSL10 contains 16 digital I/O (DIO) signals. The DIO voltage domain is VDDO, while the input voltage can be VBAT or external voltage as outlined in Section “Measuring the Current Consumption” on page 7.

The DIO signals on RSL10 are multiplexed with several interfaces, including:

- One I²C interface (DIO [7:8])
- Four external inputs to the low-speed analog to digital converters (DIO [0:3])
- One PCM interface
- Two PWM drivers
- Two SPI interfaces (DIO [13:15])
- One UART interface (DIO [4:5])
- Support interfaces that can be used to monitor control of the RF front-end and Bluetooth® baseband controller

For more information about the DIO multiplexed signals, refer to the *RSL10 Hardware Reference*.

The board provides access to any of the DIOs or their multiplexed signals via the Arduino Headers (Power1, AD1, IOL1, and IOH1).

The LED circuit provides visual monitoring of the DIOs; refer to Section “LED Circuitry” on page 7 for further information.

Power Supplies

There are several external power supplies available on your Evaluation and Development Board.

The user can also access signals on various headers on boards, as described throughout this document.

The external power supplies available for QFN boards are:

- VBUS, 5 V from USB connection – available only when USB is plugged in
- V3.3, 3.3 V from LDO – available when regulated supply is selected
- VEXT, (P5 header) unregulated external supply – available when unregulated supply is selected
- Battery (J5 Battery Holder, 12 mm coin cell battery)

Export Control Classification Number (ECCN)

The ECCN designation for RSL10 is 5A991.g.

APPENDIX A – CONNECTORS

Overview

This appendix lists all connectors on the Evaluation and Development Board. The sections that follow provide descriptions for:

- Jumpers and their possible configurations
- Headers
- Switches and their possible configurations
- Connectors

Configuration Header Jumpers

Table 3. JUMPER DESCRIPTIONS

Designator	Description
P4	Regulated or Unregulated power supply selection
P10	VBAT Power Source selection (3.3 V, Vext or Battery)
P9	VDDO selection (VBAT_DUT, 3.3 V)
P8	VDD_AT selection (3.3 V, VDDO)
P1	Onboard JTAG debugger connection

Headers

Table 4. HEADER DESCRIPTIONS

Designator	Description
POWER1	Arduino Power header 3.3 V, VDDO, nRESET, GND
AD1	Arduino Analog Inputs header A [0:3]
IOL1	Arduino IOL header UART, INT [0:1], SPI2
IOH1	Arduino IOH header I2C, SPI1
P2	External JTAG debug connection header
P3	Current measurement header
P5	External power supply header
P6	Input and output of level shifter

Switches

Table 5. SWITCH DESCRIPTIONS

Designator	Description
SW1	Pushbutton switch to reset RSL10
SW2	Pushbutton switch for DIO5

Connectors

Table 6. CONNECTOR DESCRIPTIONS

Designator	Description
J1	RF switch connector
J2	Micro USB port for power supply, JTAG and UART emulation
J3	MCU programming connector
J4	Digilent PMOD peripheral connector I2C, SPI1, INT0
J5	Battery Holder (12 mm coin cell)

APPENDIX B – SCHEMATICS

This appendix contains schematics for the Evaluation and Development Board, version 1.3:

- The Top-level (Arduino interface) schematic
- The RSL10 schematic
- The Interface MCU schematic
- The Power Supply schematic

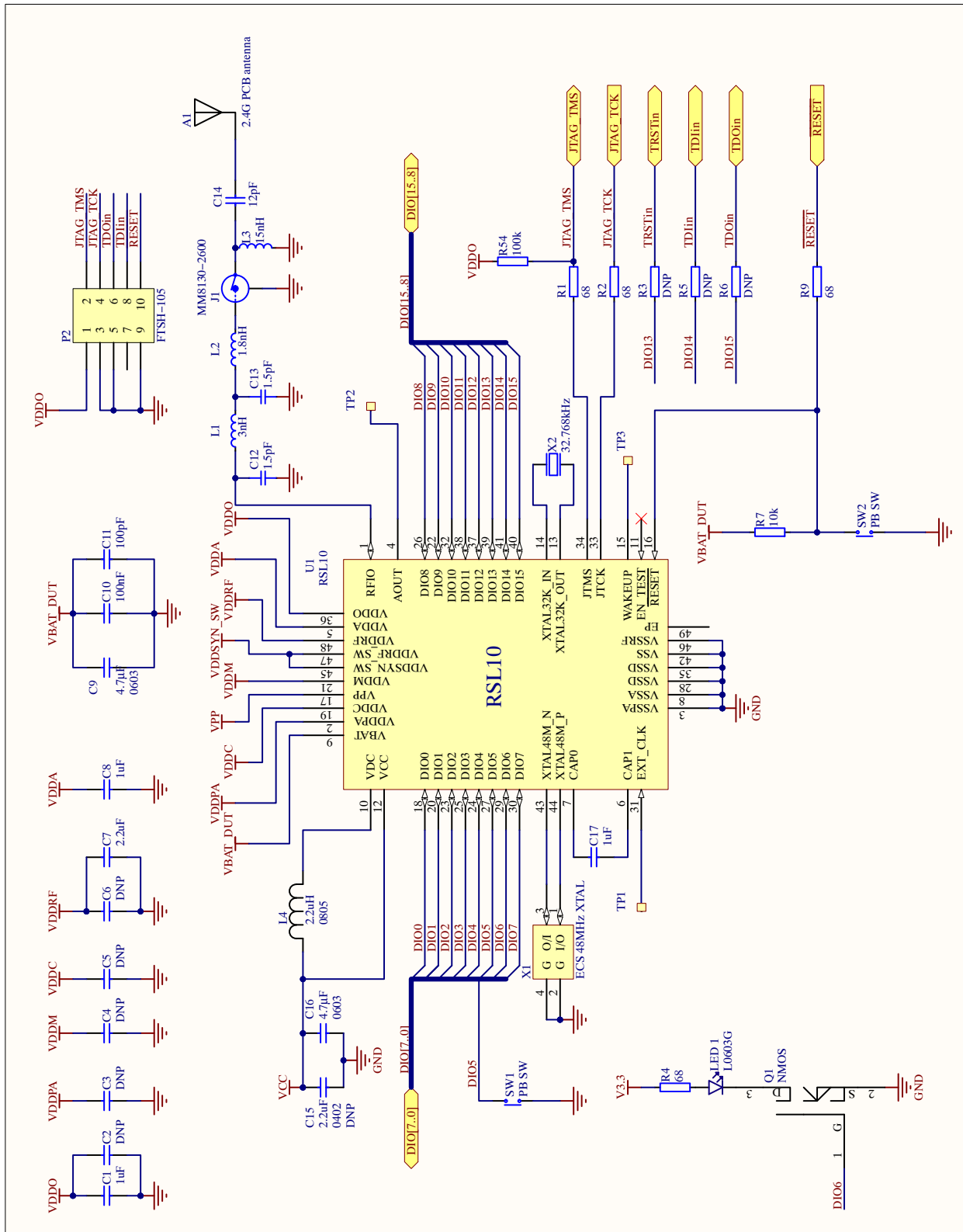

Figure 8. RSL10 SoC Schematic

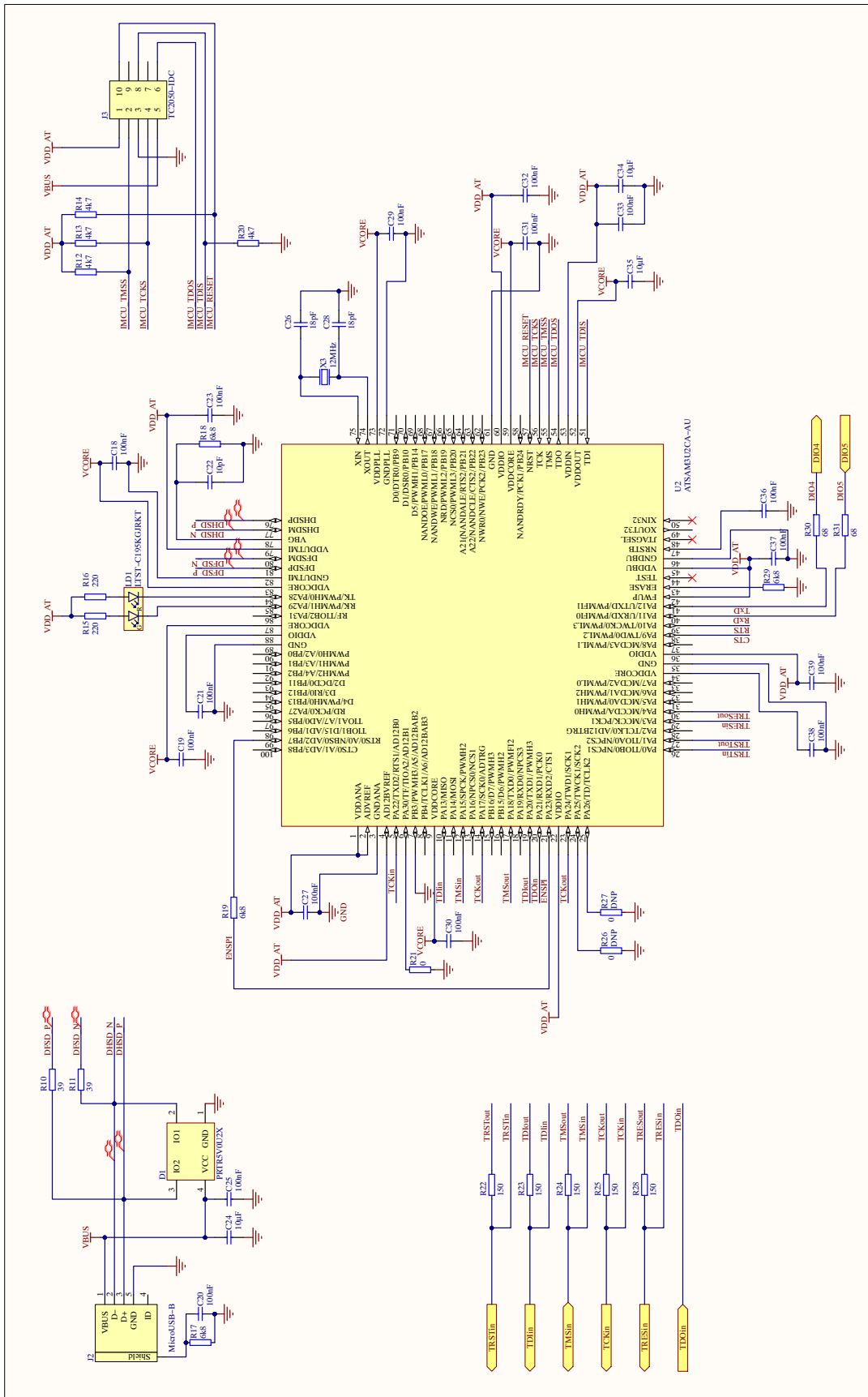

Figure 9. Interface MCU Schematic

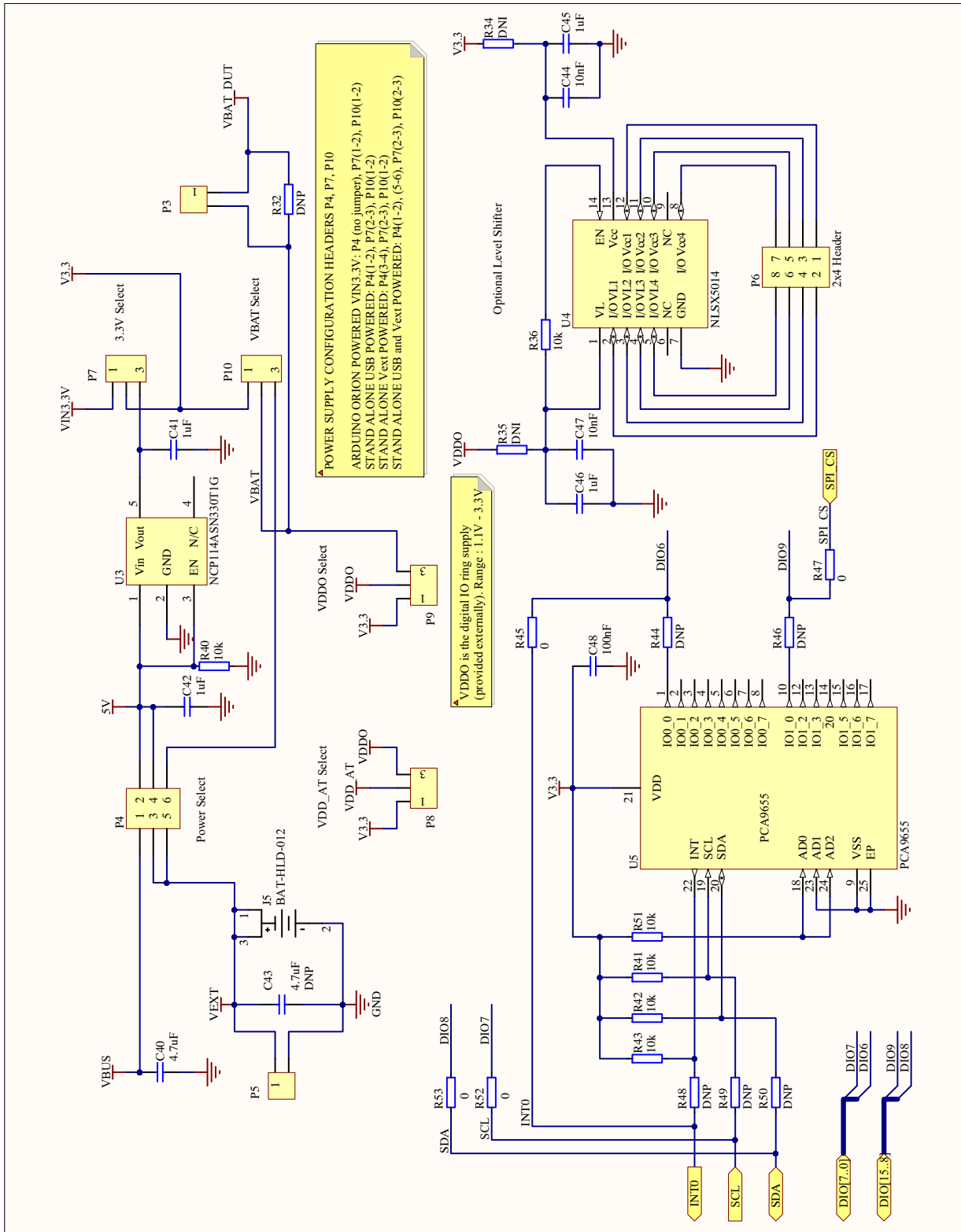

Figure 10. Power Supply Schematic

EVBUM2529/D

APPENDIX C – BILL OF MATERIALS

Table 7. BILL OF MATERIALS FOR RSL10 QFN EVALUATION AND DEVELOPMENT BOARD VERSION 1.3

Designator	Description	Footprint Doc	Manufacturer Part Number	Supplier Part Number
AD1	Arduino Stackable Header 6-pin	n/a	SSQ-106-03-G-S	SAM1198-06-ND
C2, C3, C4, C5, C6	Capacitor, NP0, ±2%	0402	GRM1555C1E120GA01D	490-8169-1-ND
C7	CAP CER 2.2 µF 10 V X5R 0402	0402	GRM155R61A225KE95D	490-10451-1-ND
C9, C16,C40	CAP CER 4.7 µF 10 V X5R 0603, CAP CER 4.7 µF 25 V X5R 0603	0603	GRM188R61A475KE15D	490-10477-1-ND
C11	Capacitor, NP0, ±2%	0402	GRM1555C1H101JA01J	490-7754-1-ND
C12, C13	CAP CER 1.5 PF 50 V NP0 0402	0402	GCM1555C1H1R5CA16D	490-13289-1-ND
C14	Capacitor, NP0, ±2%	0402	GRM1555C1E120GA01D	490-8169-1-ND
C10,C18, C19, C20, C21, C23, C25, C27, C29, C30, C31, C32, C33, C36, C37, C38, C39,C48	Capacitor, NP0, ±2%	0402	GRM155R61E104KA87D	490-5920-1-ND
C22	Capacitor, NP0, ±2%	0402	GRM1555C1E100JA01D	490-6168-1-ND
C24, C34, C35	Capacitor, X5R, ±10%	0603	GRM188R61A106KE69D	490-10474-1-ND
C26, C28	Capacitor, NP0, ±2%	0402	GRM1555C1E180JA01D	490-6172-1-ND
C1, C8, C17, C41, C42, C45, C46	Capacitor, NP0, ±10%	0402	GRM155R61A105KE15D	490-3890-1-ND
C44, C47	Capacitor, NP0, ±2%	0402	GRM155R71H103KA88D	490-4516-1-ND
D1	Ultra low capacitance double rail-to-rail ESD protection diode	SOT-143B	PRTR5V0U2X,215	588-4140-1-ND
IOH1	Arduino Stackable Header 10-pin		SSQ-110-03-G-S	SAM1198-10-ND
IOL1, POWER1	Arduino Stackable Header 8-Pin		SSQ-108-03-G-S	SAM1198-08-ND
J1	Coaxial Connector with Switch	COAXIAL-SWF	MM8130-2600RA2	490-4981-1-ND
J2	MicroUSB-B-SMT	FCI_10118193-0001LF	10118193-0001LF	609-4616-1-ND
J4	WR-PHD 2.54 mm Angled Dual Socket Header, 12p		613012243121	S5559-ND
J5	HOLDER BATTERY 12 MM COIN		2996	36-2996-ND
L1	FIXED IND 3NH 800MA 170 MOHM SMD	0402	LQG15HS3N0S02D	490-6570-1-ND
L2	FIXED IND 1.8NH 950MA 100 MOHM	0402	LQG15HS1N8S02D	490-2613-1-ND
L3	Inductor, 320 mA, ±5%	0402	HK100515NJ-T	587-1521-1-ND
L4	Imported	0805	CKP2012N2R2M-T	587-2771-1-ND
LD1	Ultra bright AllnGaP Bi-Color LED	LED_DUAL_0606	LTST-C195KGJRKT	160-1452-1-ND
LED 1	LED SMARTLED GREEN 570NM 0603	0603	LNJ337W83RA	LNJ337W83RACT-ND
P1, P4	Header 2x3 SMT		15-91-2060	WM17449-ND
P2	SAMTEC – CONN HEADER 10POS DUAL .05” SMD KEYING SHROUD	FTSH-105	FTSH-105-01-F-DV-K	SAM8796-ND
P3, P5	HEADER, 2POS, 1ROW; Series: 961; Pitch Spacing: 2.54 mm; RA		961102-5604-AR	3M9467-ND
P6	2x4 Pin Header		15-91-2080	WM17450-ND
P7, P8, P9, P10	HEADER, 3POS, 1ROW; Series: 961; Pitch Spacing: 2.54 mm;		961103-6404-AR	3M9448-ND
Q1	NMOS Transistor	SOT65P210X105-3N	RU1J002YNTCL	RU1J002YNTCLCT-ND
R1, R2, R4, R9, R30, R31	Resistor, ±1%, 0.063 W	0402	ERJ-2RK6F68R0X	P68.0LCT-ND

EVBUM2529/D

Table 7. BILL OF MATERIALS FOR RSL10 QFN EVALUATION AND DEVELOPMENT BOARD VERSION 1.3

Designator	Description	Footprint Doc	Manufacturer Part Number	Supplier Part Number
R3, R5, R6, R26, R27, R32, R44, R46, R48, R49, R50,	Resistor, ±1%, 0.063 W	0402	ERJ-2RKF68R0X, ERJ-2RKF68R0X, ERJ-2RKF68R0X, ERJ-2GE0R00X, ERJ-2GE0R00X, ERJ-2GE0R00X, ERJ-2GEJ103X, ERJ-2GEJ103X, ERJ-2GEJ103X, ERJ-2GE0R00X, ERJ-2GE0R00X, ERJ-2GE0R00X, ERJ-2GE0R00X, ERJ-2GE0R00X, ERJ-2GE0R00X, ERJ-2GEJ103X	P68.0LCT-ND, P68.0LCT-ND, P68.0LCT-ND, P0.0JCT-ND, P0.0JCT-ND, 173-8862, P10KJCT-ND, P10KJCT-ND, P10KJCT-ND, 173-8862, 173-8862, 173-8862, 173-8862, 173-8862, P10KJCT-ND
R7, R36, R40, R41, R42, R43, R51	Resistor, ±1%, 0.1 W	0402	ERJ-2GEJ103X	P10KJCT-ND
R10, R11	Resistor, ±1%, 0.1 W	0402	ERJ-2RKF39R0X	P39.0LCT-ND
R12, R13, R14, R20	Resistor, ±1%, 0.1 W	0402	ERJ-2RKF4701X	P4.70KLCT-ND
R15, R16	Resistor, ±1%, 0.1 W	0402	ERJ-2RKF2200X	P220LCT-ND
R17, R18, R19, R29	Resistor, ±1%, 0.1 W	0402	ERJ-2RKF6801X	P6.80KLCT-ND
R21, R45, R47, R52, R53	Resistor, ±1%, 0.1 W	0402	ERJ-2GE0R00X	P0.0JCT-ND
R22, R23, R24, R25, R28	Resistor, ±1%, 0.1 W	0402	ERJ-2RKF1500X	173-8862
R54	Resistor, ±1%, 0.1 W	0402	ERJ-2RKF1003X	P100KLCT-ND
SW1, SW2	ALPS – SKHUALE010 – Tactile Switch, SPNO, SMD, 6.5 x 6.2 x 2.5 mm	ALPS_SKHUxxx010_WO_GND	SKHUALE010	35-790-00
U1	RSL10 QFN			
U2	IC MCU 32 bit 128 kB flash 100LQFP	LQFP-100	ATSAM3U2CA-AU	ATSAM3U2CA-AU-ND
U3	IC REG LIN 3.3 V 600MA 5TSOP	TSOP-5IPC	NCP114ASN330T1G	NCP114ASN330T1GOSCT-ND
U4	TRANSLATOR LEVEL 4BIT 14-TSSOP	TSOP65P640X120-14N	NLSX5014DTR2G	NLSX5014DTR2GOSCT-ND
U5	Remote 16-bit expander	QFN50P400X400	PCA9655EMTTXG	PCA9655EMTTXGOSDKR-ND
X1	ECS 48 MHz Crystal	XTAL 4 pads	ECS-480-8-47-JTN-TR	XC1969CT-ND
X2	EPSON TOYOCOM – FC-135 32.768 kHz ±20 PPM	XTAL_3215	FC-135 32.768KHZ ±20PPM	FC-135 32.7680KA-AC-ND
X3	XTAL SMD 3225, 12 MHz, 18 pF, ±30 ppm	BT-XTAL_3225	7M-12.000MAAJ-T	887-1121-1-ND
See Jumper Location	CONN JUMPER SHORTING GOLD FLASH	CONN JUMPER (2.54mm) Gold	SPC02SYAN	S9001-ND
See Installation	MACHINE SCREW PAN PHILLIPS 4-40	n/a	NY PMS 440 0025 PH	H542-ND
See Installation	HEX STANDOFF 4-40 NYLON 3/8"	n/a	1902B	36-1902B-ND

NOTE: Designators C2, C3, C4, C5, C6 and R3, R5, R6, R26, R27, R32, R44, R46, R48, R49, R50 are not populated.

onsemi, **Onsemi**, and other names, marks, and brands are registered and/or common law trademarks of Semiconductor Components Industries, LLC dba "**onsemi**" or its affiliates and/or subsidiaries in the United States and/or other countries. **onsemi** owns the rights to a number of patents, trademarks, copyrights, trade secrets, and other intellectual property. A listing of **onsemi**'s product/patent coverage may be accessed at www.onsemi.com/site/pdf/Patent-Marking.pdf. **onsemi** is an Equal Opportunity/Affirmative Action Employer. This literature is subject to all applicable copyright laws and is not for resale in any manner.

The evaluation board/kit (research and development board/kit) (hereinafter the "board") is not a finished product and is not available for sale to consumers. The board is only intended for research, development, demonstration and evaluation purposes and will only be used in laboratory/development areas by persons with an engineering/technical training and familiar with the risks associated with handling electrical/mechanical components, systems and subsystems. This person assumes full responsibility/liability for proper and safe handling. Any other use, resale or redistribution for any other purpose is strictly prohibited.

THE BOARD IS PROVIDED BY ONSEMI TO YOU "AS IS" AND WITHOUT ANY REPRESENTATIONS OR WARRANTIES WHATSOEVER. WITHOUT LIMITING THE FOREGOING, ONSEMI (AND ITS LICENSORS/SUPPLIERS) HEREBY DISCLAIMS ANY AND ALL REPRESENTATIONS AND WARRANTIES IN RELATION TO THE BOARD, ANY MODIFICATIONS, OR THIS AGREEMENT, WHETHER EXPRESS, IMPLIED, STATUTORY OR OTHERWISE, INCLUDING WITHOUT LIMITATION ANY AND ALL REPRESENTATIONS AND WARRANTIES OF MERCHANTABILITY, FITNESS FOR A PARTICULAR PURPOSE, TITLE, NON-INFRINGEMENT, AND THOSE ARISING FROM A COURSE OF DEALING, TRADE USAGE, TRADE CUSTOM OR TRADE PRACTICE.

onsemi reserves the right to make changes without further notice to any board.

You are responsible for determining whether the board will be suitable for your intended use or application or will achieve your intended results. Prior to using or distributing any systems that have been evaluated, designed or tested using the board, you agree to test and validate your design to confirm the functionality for your application. Any technical, applications or design information or advice, quality characterization, reliability data or other services provided by **onsemi** shall not constitute any representation or warranty by **onsemi**, and no additional obligations or liabilities shall arise from **onsemi** having provided such information or services.

onsemi products including the boards are not designed, intended, or authorized for use in life support systems, or any FDA Class 3 medical devices or medical devices with a similar or equivalent classification in a foreign jurisdiction, or any devices intended for implantation in the human body. You agree to indemnify, defend and hold harmless **onsemi**, its directors, officers, employees, representatives, agents, subsidiaries, affiliates, distributors, and assigns, against any and all liabilities, losses, costs, damages, judgments, and expenses, arising out of any claim, demand, investigation, lawsuit, regulatory action or cause of action arising out of or associated with any unauthorized use, even if such claim alleges that **onsemi** was negligent regarding the design or manufacture of any products and/or the board.

This evaluation board/kit does not fall within the scope of the European Union directives regarding electromagnetic compatibility, restricted substances (RoHS), recycling (WEEE), FCC, CE or UL, and may not meet the technical requirements of these or other related directives.

FCC WARNING – This evaluation board/kit is intended for use for engineering development, demonstration, or evaluation purposes only and is not considered by **onsemi** to be a finished end product fit for general consumer use. It may generate, use, or radiate radio frequency energy and has not been tested for compliance with the limits of computing devices pursuant to part 15 of FCC rules, which are designed to provide reasonable protection against radio frequency interference. Operation of this equipment may cause interference with radio communications, in which case the user shall be responsible, at its expense, to take whatever measures may be required to correct this interference.

onsemi does not convey any license under its patent rights nor the rights of others.

LIMITATIONS OF LIABILITY: **onsemi** shall not be liable for any special, consequential, incidental, indirect or punitive damages, including, but not limited to the costs of requalification, delay, loss of profits or goodwill, arising out of or in connection with the board, even if **onsemi** is advised of the possibility of such damages. In no event shall **onsemi**'s aggregate liability from any obligation arising out of or in connection with the board, under any theory of liability, exceed the purchase price paid for the board, if any.

The board is provided to you subject to the license and other terms per **onsemi**'s standard terms and conditions of sale. For more information and documentation, please visit www.onsemi.com.

PUBLICATION ORDERING INFORMATION

LITERATURE FULFILLMENT:

Email Requests to: orderlit@onsemi.com

onsemi Website: www.onsemi.com

TECHNICAL SUPPORT

North American Technical Support:

Voice Mail: 1 800-282-9855 Toll Free USA/Canada

Phone: 011 421 33 790 2910

Europe, Middle East and Africa Technical Support:

Phone: 00421 33 790 2910

For additional information, please contact your local Sales Representative