

May.1.2023 Copyright 2023 HIROSE ELECTRIC CO., LTD. All Rights Reserved.
 In case of consideration for using Automotive equipment / device which demand high reliability, kindly contact our sales window correspondents.

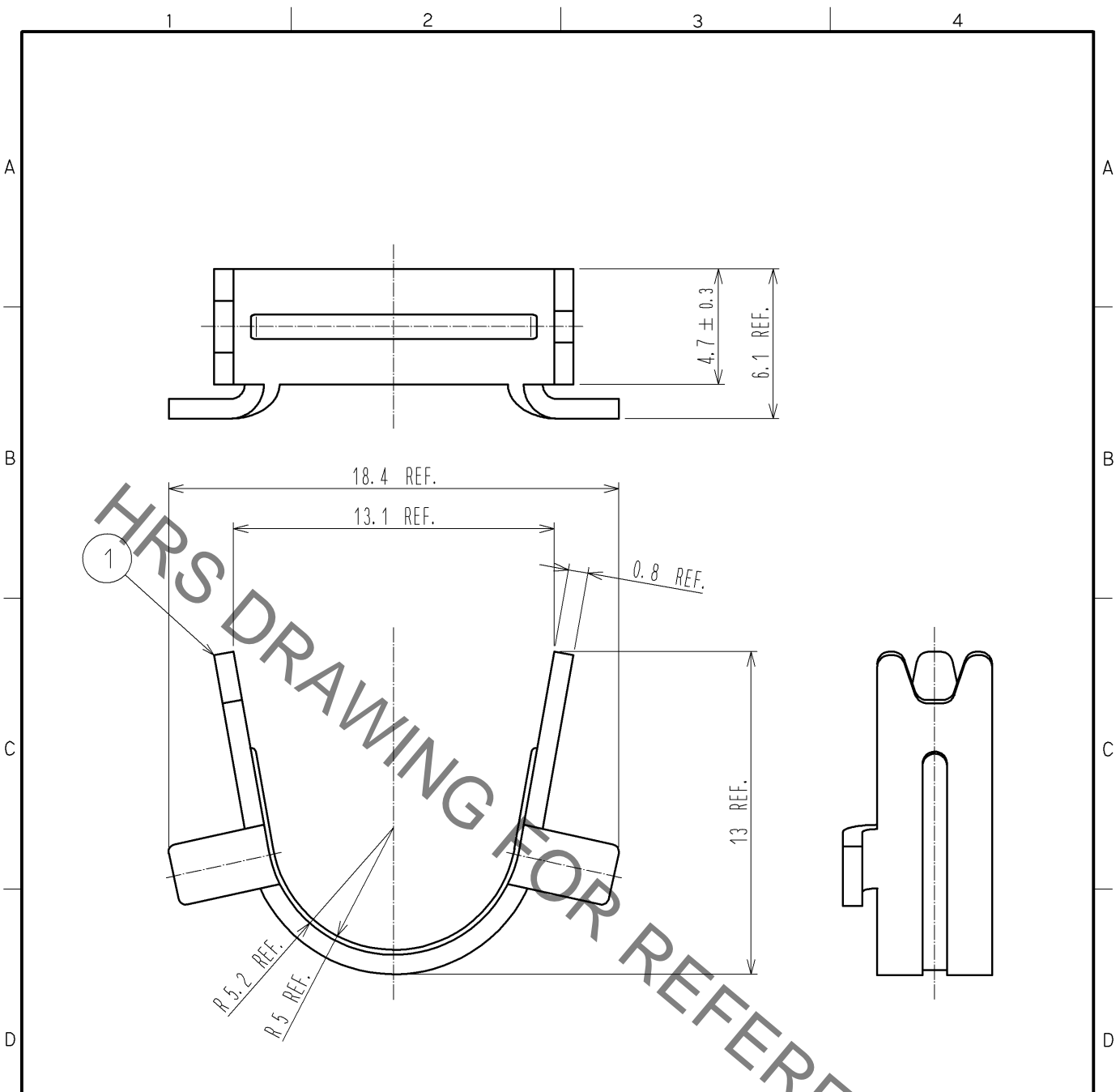

NOTE 1. THIS PRODUCT IS A CLAMP FOR A COVER CASE 'DH-51-C**B'
 2. THE APPLICABLE CABLE DIAMETER IS $\phi 9.6$
 3. THIS PRODUCT IS PACKED IN A BAG.
 (QUANTITY PER BAG MAY VARY DUE TO THE AMOUNT OF EACH ORDER.)

NO.		MATERIAL		FINISH . REMARKS		1		BRASS		FINISH . REMARKS	
UNITS mm		SCALE 4 : 1	COUNT 1	DESCRIPTION OF REVISIONS DIS-E-003059			DESIGNED MO. SHIMOYAMA	CHECKED KN. ICHIKAWA	DATE 09.12.07		
HRS HIROSE ELECTRIC CO., LTD.		APPROVED : AO. SUZUKI	09.10.05	DRAWING NO.		EDC4-126660-00					
		CHECKED : KN. ICHIKAWA	09.10.02	PART NO.		DH-51-CMB(9.6)					
		DESIGNED : TU. TANIGUCHI	09.10.02	CODE NO.		CL244-0034-3-00					
		DRAWN : TU. TANIGUCHI	09.10.02			1/1					