

Apr.1.2023 Copyright 2023 HIROSE ELECTRIC CO., LTD. All Rights Reserved.
In case of consideration for using Automotive equipment / device which demand high reliability, kindly contact our sales window correspondents.

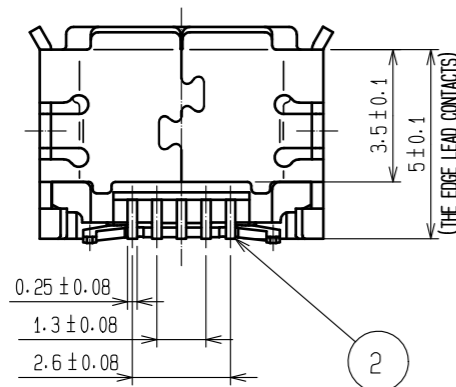

HRS DRAWING FOR REFERENCE

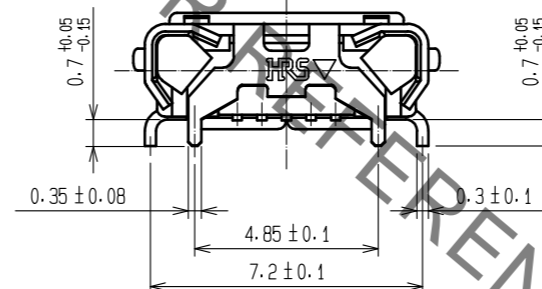
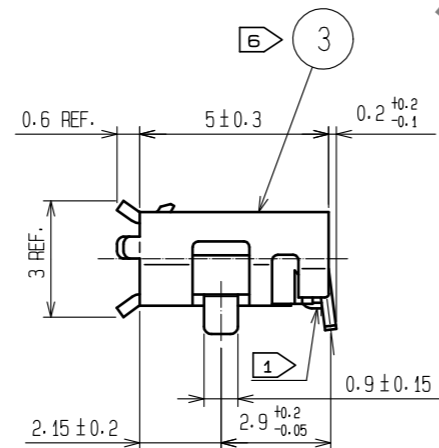
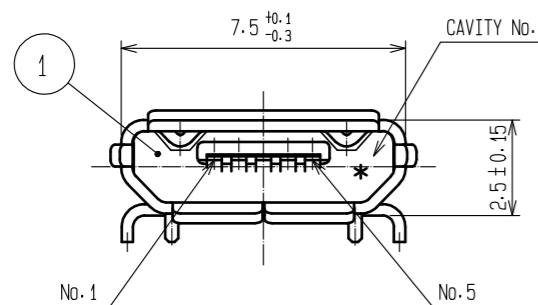
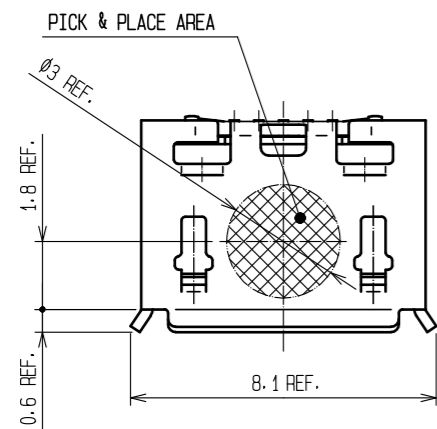
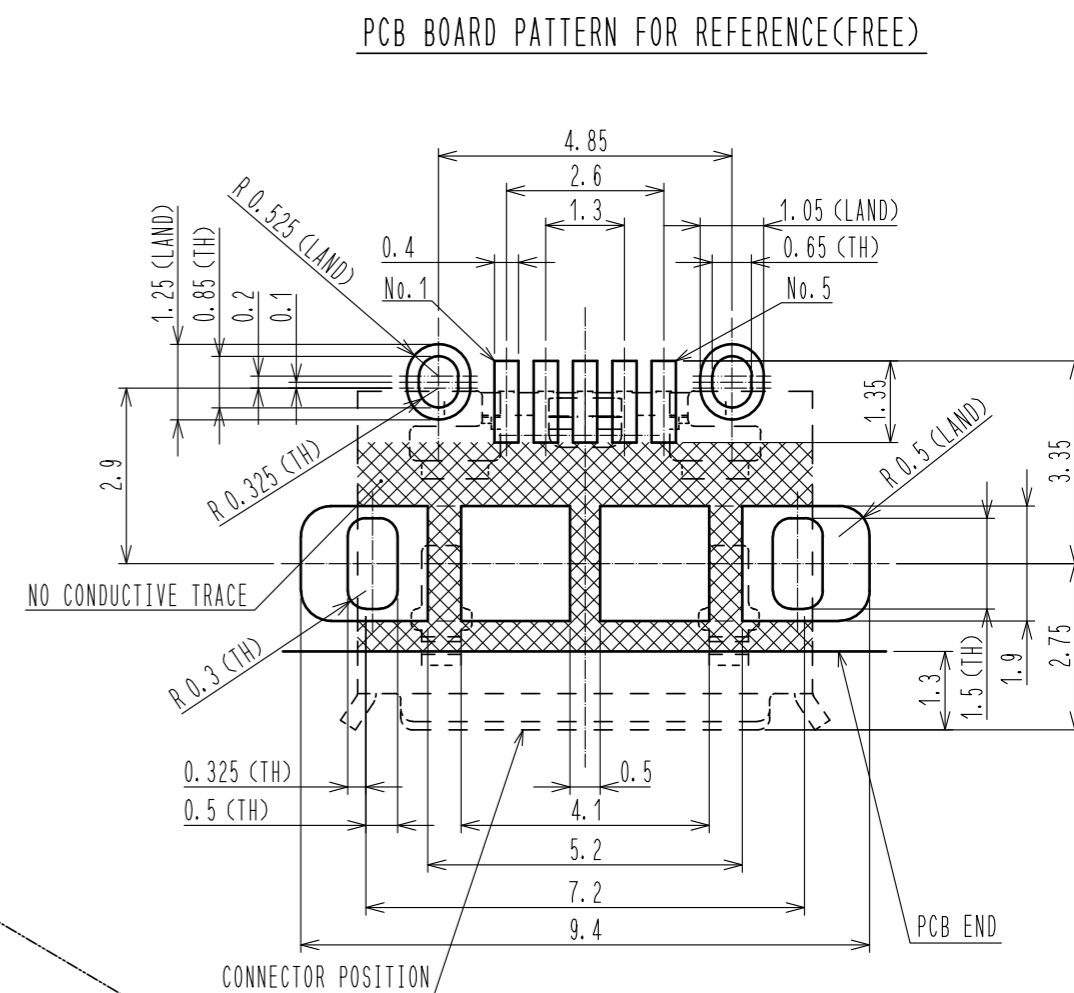

GENERAL TOLERANCE IS ±0.05mm

- NOTES.
- ① CO-PLANARITY IS WITHIN 0.08mm MAX.
 - ② PLATING
CONTACT AREA :GOLD 0.05μm MIN OVER PALLADIUM NICKEL 0.75μm MIN.
LEAD AREA :GOLD 0.05μm MIN.
UNDER PLATING:NICKEL 2μm MIN.
 - ③ PER REEL : 2000 pcs.
 - 4. INTERFACE DIMENSIONS TO USB2.0 SPECIFICATION.
 - 5. AS FOR PART No.3, THE PERFORMANCE REMAINS GOOD EVEN IF THERE IS A RUBBING WOUND BY THE ASSEMBLY PROCESS.
 - ⑥ AS FOR PART No.3, THERE IS NO PROBLEM ON THE QUALITY THOUGH THERE MIGHT BE A DIFFERENCE IN THE COLOR DEPENDING ON THE PLATING PROCESSING LOT.

2	COPPER ALLOY	②	5	PE	
1	LCP	BLACK UL94V-0	4	PS	
			3	STAINLESS STEEL	OVER PLATING : TIN 3.8μm MIN. UNDER PLATING : NICKEL 1.25μm MIN. LUBRICANT
NO.	MATERIAL	FINISH . REMARKS	NO.	MATERIAL	FINISH . REMARKS
UNITS	mm	SCALE	5 : 1	COUNT	DESCRIPTION OF REVISIONS
					DESIGNED
					CHECKED
					DATE
APPROVED : NM. NISHIMATSU		15.10.27	DRAWING NO. EDC-126863-30-00		
CHECKED : KN. ICHIKAWA		15.10.27	PART NO. ZX62D-B-5PA8(30)		
DESIGNED : TS. ITO		15.10.27	CODE NO. CL242-0056-3-30		
DRAWN : AK. AKIYAMA		15.10.27	①/②		

Apr.1.2023 Copyright 2023 HIROSE ELECTRIC CO., LTD. All Rights Reserved.
 In case of consideration for using Automotive equipment / device which demand high reliability, kindly contact our sales window correspondents.

PANEL CUTOUT FOR REFERENCE

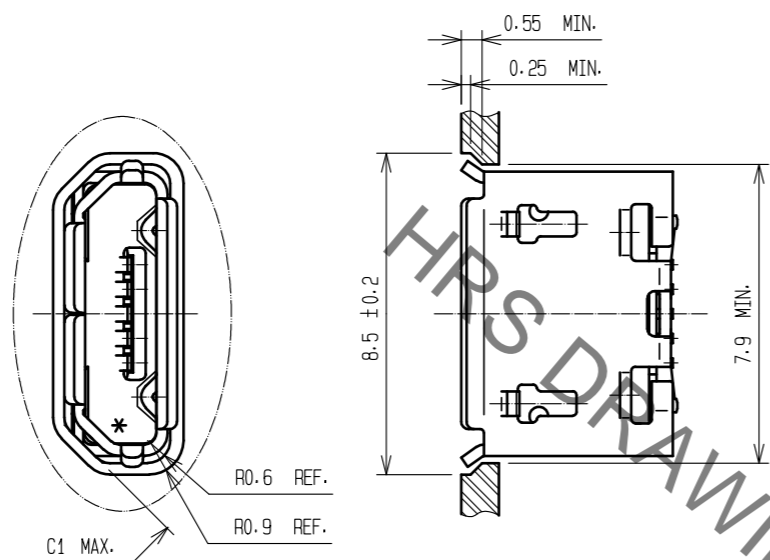

③ DRAWING FOR PACKING(FREE)

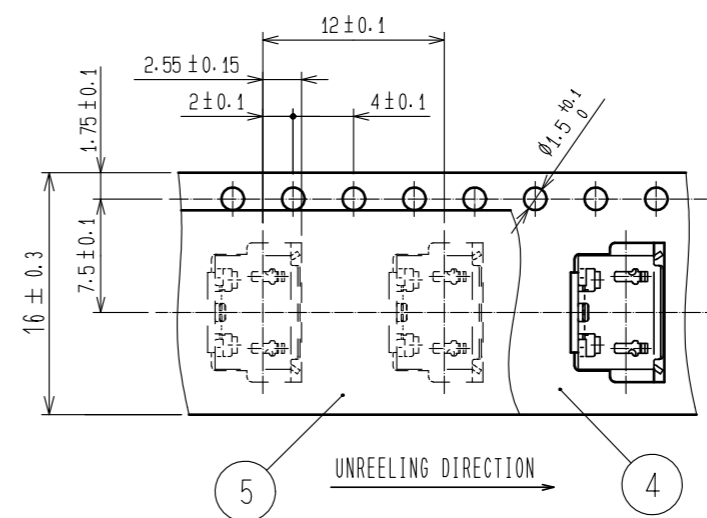

MATED WITH CORRESPONDING PLUG

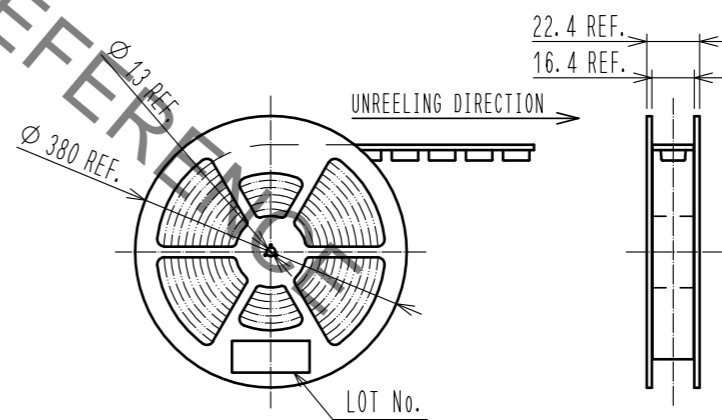
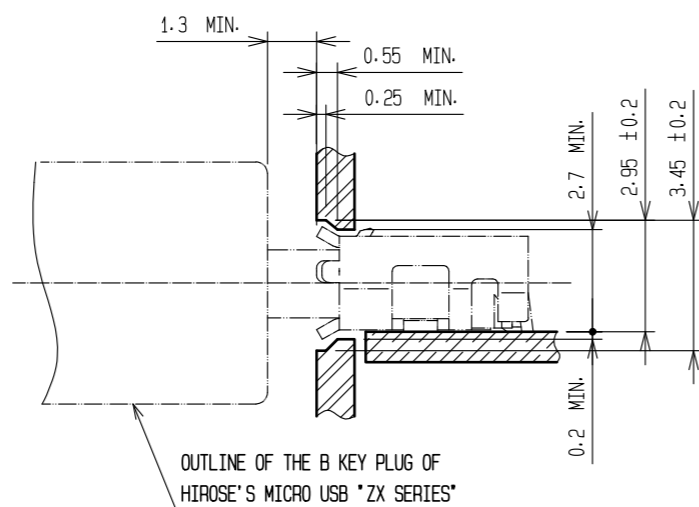

HRS	DRAWING NO.	EDC-126863-30-00
	PART NO.	ZX62D-B-5PA8(30)
	CODE NO.	CL242-0056-3-30
		2/2