

May.1.2023 Copyright 2023 HIROSE ELECTRIC CO., LTD. All Rights Reserved.
 In case of consideration for using Automotive equipment / device which demand high reliability, kindly contact our sales window correspondents.

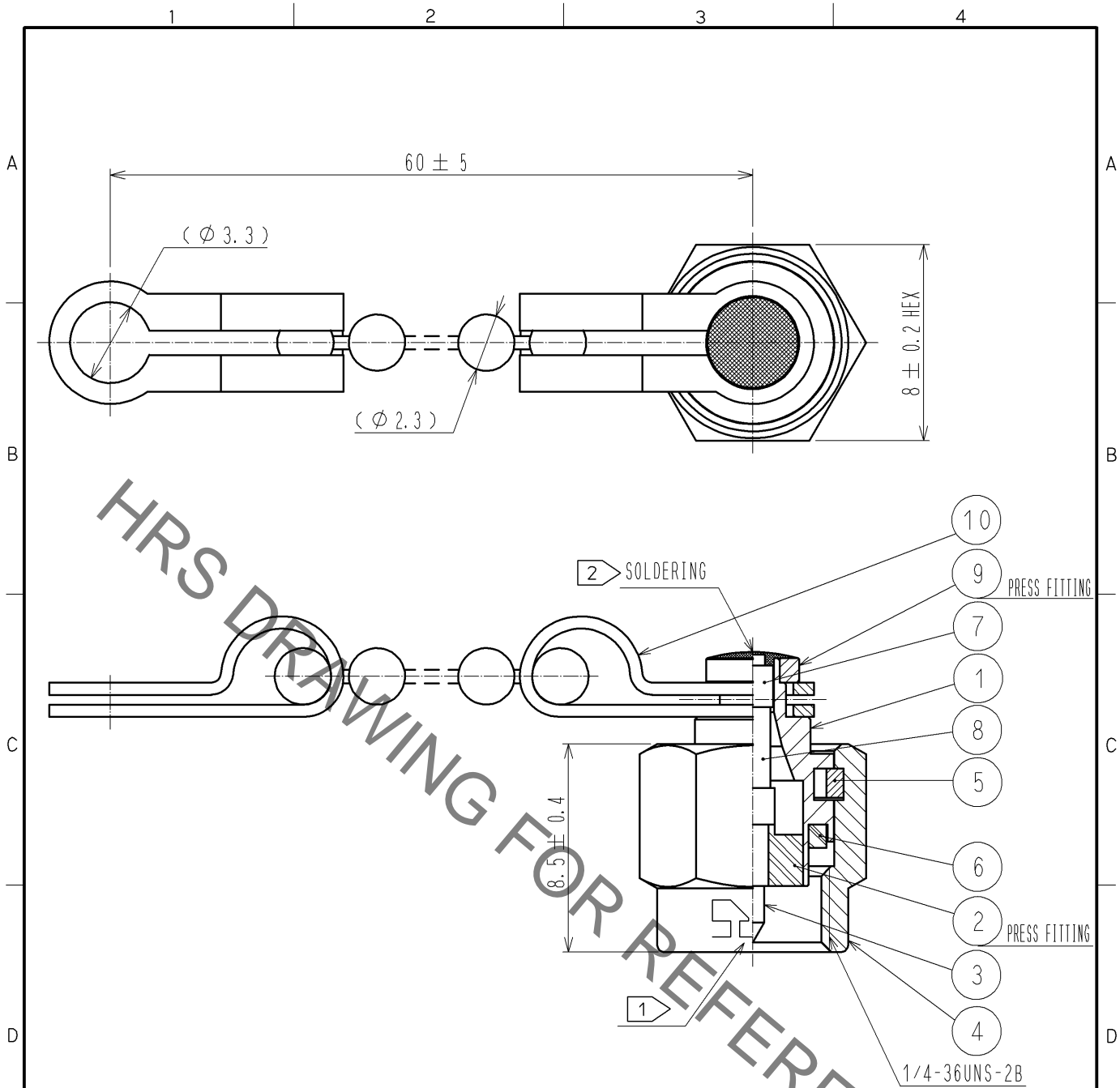

NOTE ① HRS SHALL BE INDICATED AT THE POSITION AS SHOWN.
 ② USE LEAD FREE SOLDER(Sn3.0Ag0.5Cu).

5	BERYLLIUM COPPER	NICKEL PLATING	10	STAINLESS STEEL	PASSIVATE
4	STAINLESS STEEL	PASSIVATE	9	STAINLESS STEEL	NICKEL PLATING
3	BRASS	GOLD PLATING	8	RESISTANCE	50Ω
2	PTFE		7	BRASS	GOLD PLATING
1	STAINLESS STEEL	NICKEL PLATING	6	SILICONE RUBBER	
NO.	MATERIAL	FINISH . REMARKS	NO.	MATERIAL	FINISH . REMARKS

UNITS mm	SCALE 4 : 1	COUNT	DESCRIPTION OF REVISIONS	DESIGNED	CHECKED	DATE
HIROSE ELECTRIC CO., LTD.			APPROVED : MT. SHIBUTANI 12.03.23 CHECKED : KY. SHIMIZU 12.03.23 DESIGNED : TK. SAWAGUCHI 12.03.22 DRAWN : TK. SAWAGUCHI 12.03.22	DRAWING NO. EDC4-180881-01 PART NO. HRM-601JW(51) CODE NO. CL353-0169-1-51	1/1	