

May.1.2023 Copyright 2023 HIROSE ELECTRIC CO., LTD. All Rights Reserved.
In case of consideration for using Automotive equipment / device which demand high reliability, kindly contact our sales window correspondents.

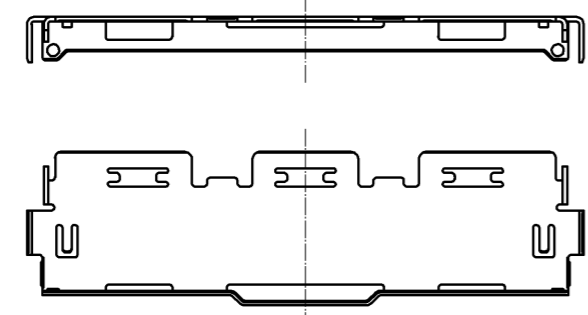

CAREER STATE DRAWING(FREE)

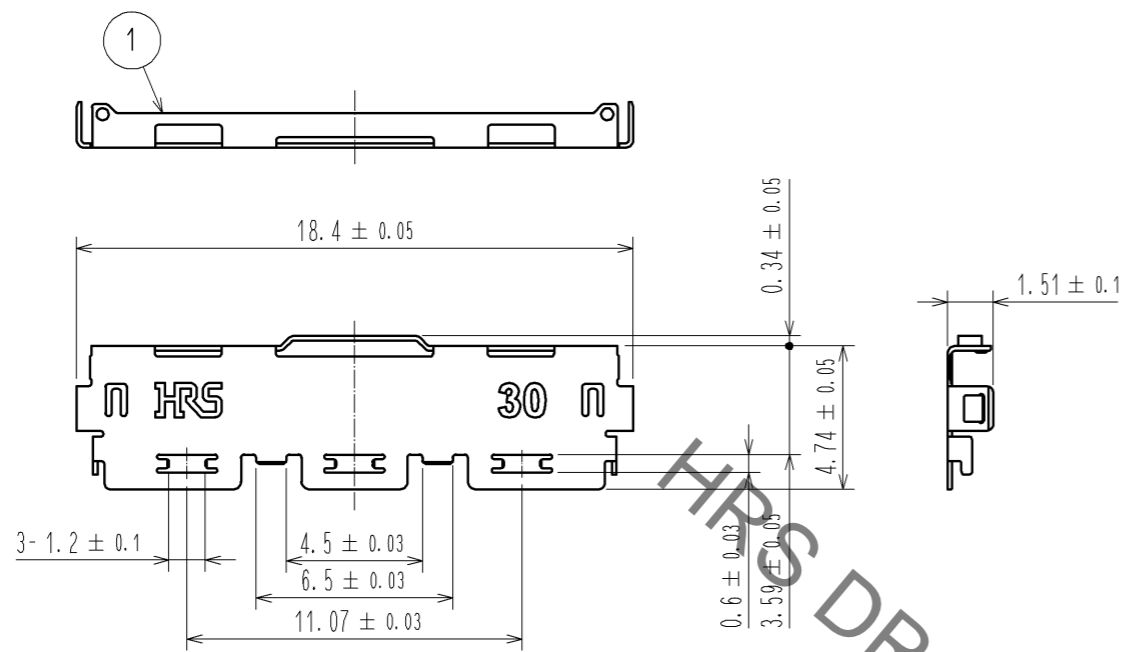
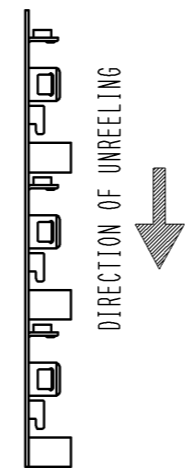
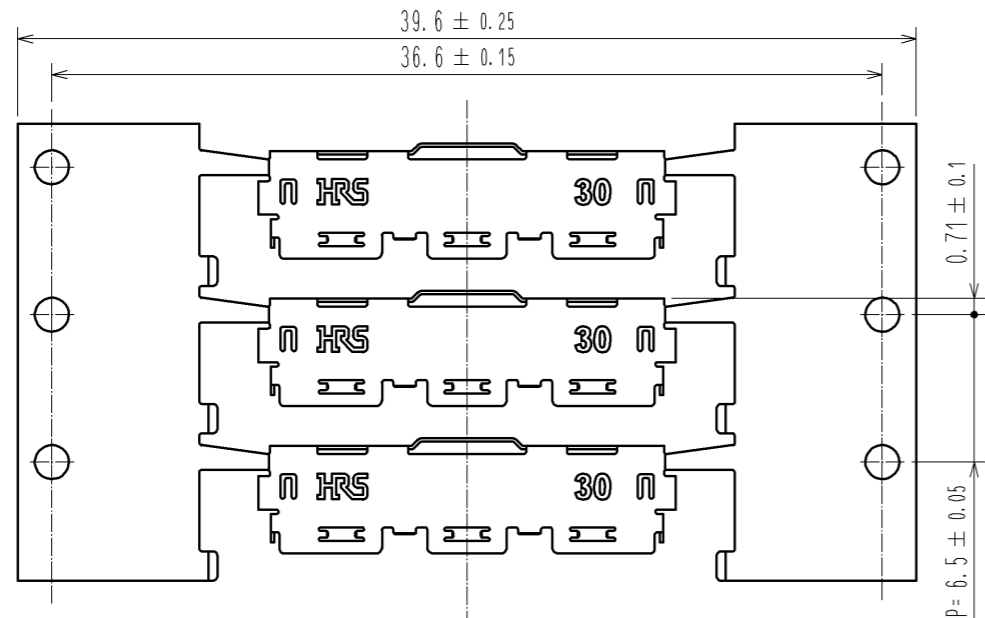

REEL STATE DRAWING (FREE)

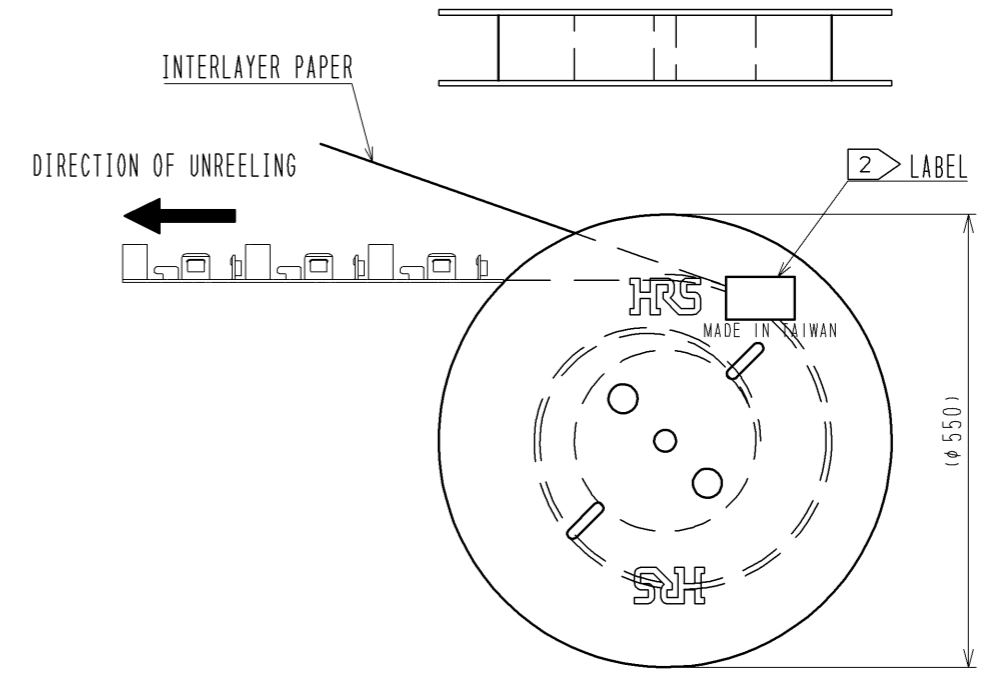

NOTES

- 1. PER REEL:10000 COMPONENTS
- 2. DETAILS OF THE LABEL ARE SHOWN BELOW.
- 3. THE ASSEMBLY IS COMPLETED BY COMBINING TWO PARTS 'CONNECTOR UNIT, AND METAL SHIELDING'. REFER TO THE TABLE FOR EACH ITEM No. PART NAME, PART No AND CODE No.

2 LABEL DETAILS

HRS		INSPECTION 検査
CODE No. 品名コード	CL662-8006-6	
PART NO. 品名	DF80-30P-SHL	
QTY 数量	10,000 PCS	
PECULIAR 仕様		
Lot No		
SPLICE 継ぎ目		

3

ITEM No.	PART NAME	PART No.	CODE No.
-	CONNECTOR UNIT	DF80D-30P-0.5SD(51)	CL662-8018-5-51
1	METAL SHIELDING	DF80-30P-SHL	CL662-8006-6-00

NO.	MATERIAL	FINISH . REMARKS	NO.	MATERIAL	FINISH . REMARKS
			1	STAINLESS	WHOLE AREA : Sn PLATING 1μmMIN UNDER PLATING : Ni PLATING 0.2μmMIN

UNITS mm	SCALE FREE	COUNT 1	DESCRIPTION OF REVISIONS DIS-D-003054	DESIGNED IO. DENPOUYA	CHECKED MH. TSUCHIDA	DATE 13.10.22
APPROVED : TS. SAKATA		12.04.18		DRAWING NO. EDC3-338298-01		
CHECED : TS. SAKATA		12.04.18		PART NO. DF80-30P-SHL		
DESIGNED : IO. DENPOUYA		12.04.18		CODE NO. CL662-8006-6-00		
DRAWN : IO. DENPOUYA		12.04.18		1/1		