

THIS DRAWING IS UNPUBLISHED. RELEASED FOR PUBLICATION 19
 © COPYRIGHT 19 BY AMP INCORPORATED, HARRISBURG, PA. ALL INTERNATIONAL RIGHTS RESERVED. AMP PRODUCTS MAY BE COVERED BY U.S. AND FOREIGN PATENTS AND/OR PATENTS PENDING.

P		F		ZONE		LTR		REVISIONS		DATE		APPROVED	
								U	OBS:-4; EC 0502-0222-96	31MAY97	03	AD	
								V	REV PER ECR-17-004131	20JUN17	ST	TD	

- FOR USE IN PRINTED CIRCUIT BOARDS .062-.094 THICK.
 - WIRE RANGE :22-26 AWG SOLID OR STRANDED WIRE. MAXIMUM INSULATION DIAMETER OF .086 IS ACCEPTABLE FOR MOST APPLICATIONS.
 - TERMINAL SHALL ACCOMMODATE ONE OR TWO WIRES OF THE SAME TYPE AND WITHIN PLUS OR MINUS ONE WIRE GAGE SIZE. EXAMPLE: 24 AWG MAY BE MIXED WITH EITHER 26 OR 22 AWG.
 - USE INSERTION TOOL, PART NUMBER 231890-1.
- △ WHEN USING TEFLON INSULATED WIRES USE 554935-1 OR 554935-2.
- △ CUT-OFF DIMENSION FOR LOOSE PIECE PARTS ONLY.

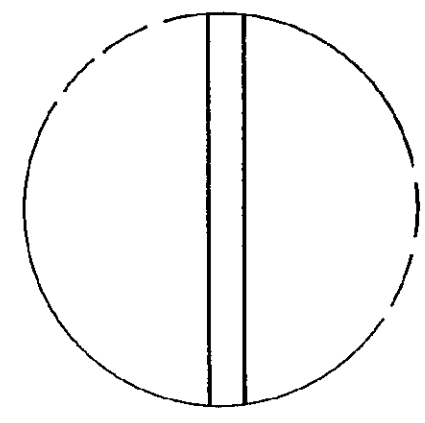
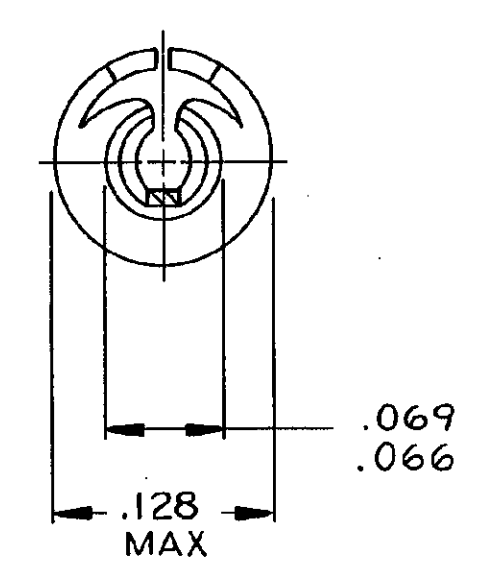
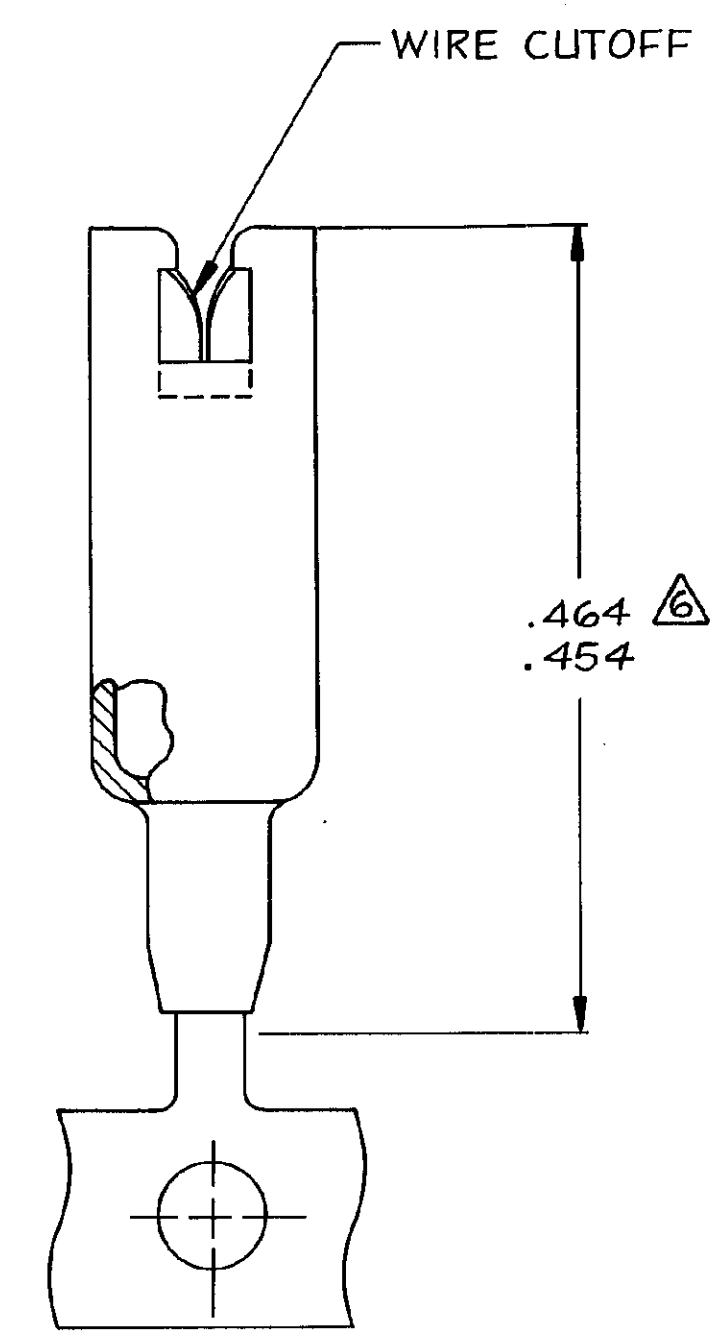
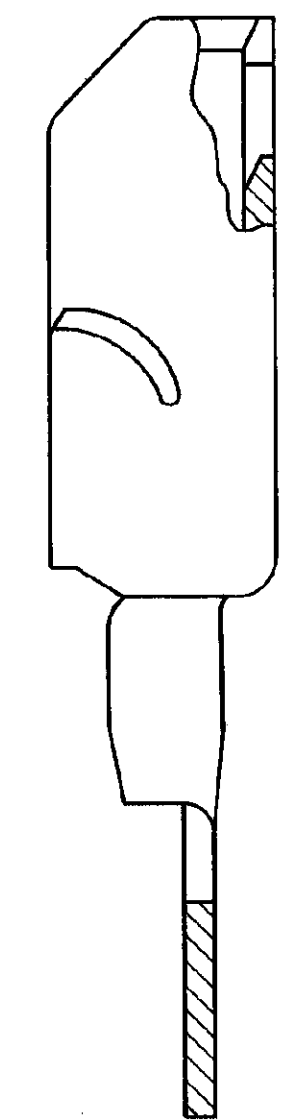
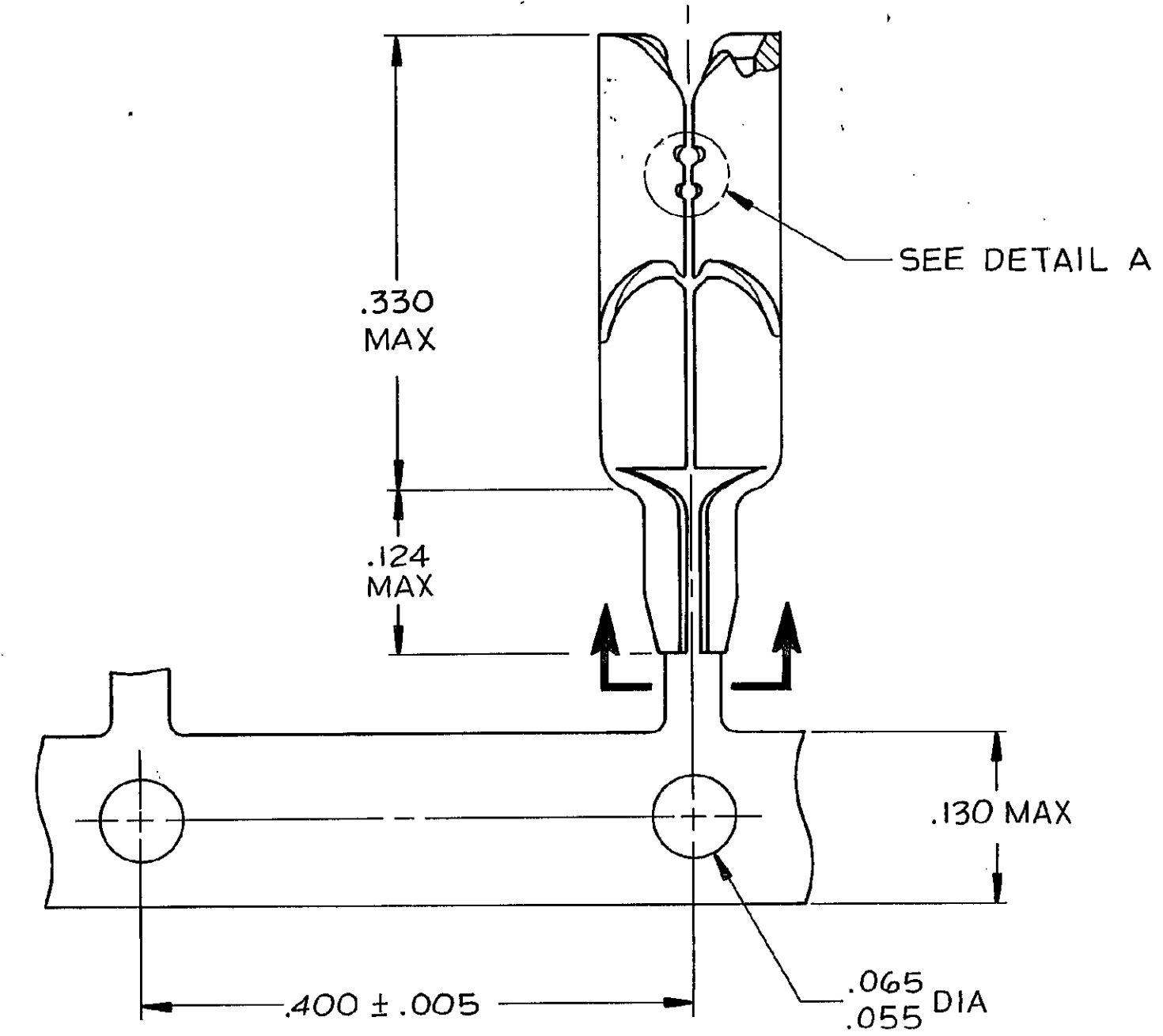

DETAIL A
SCALE-40:1
FOR -3 AND -4 ONLY

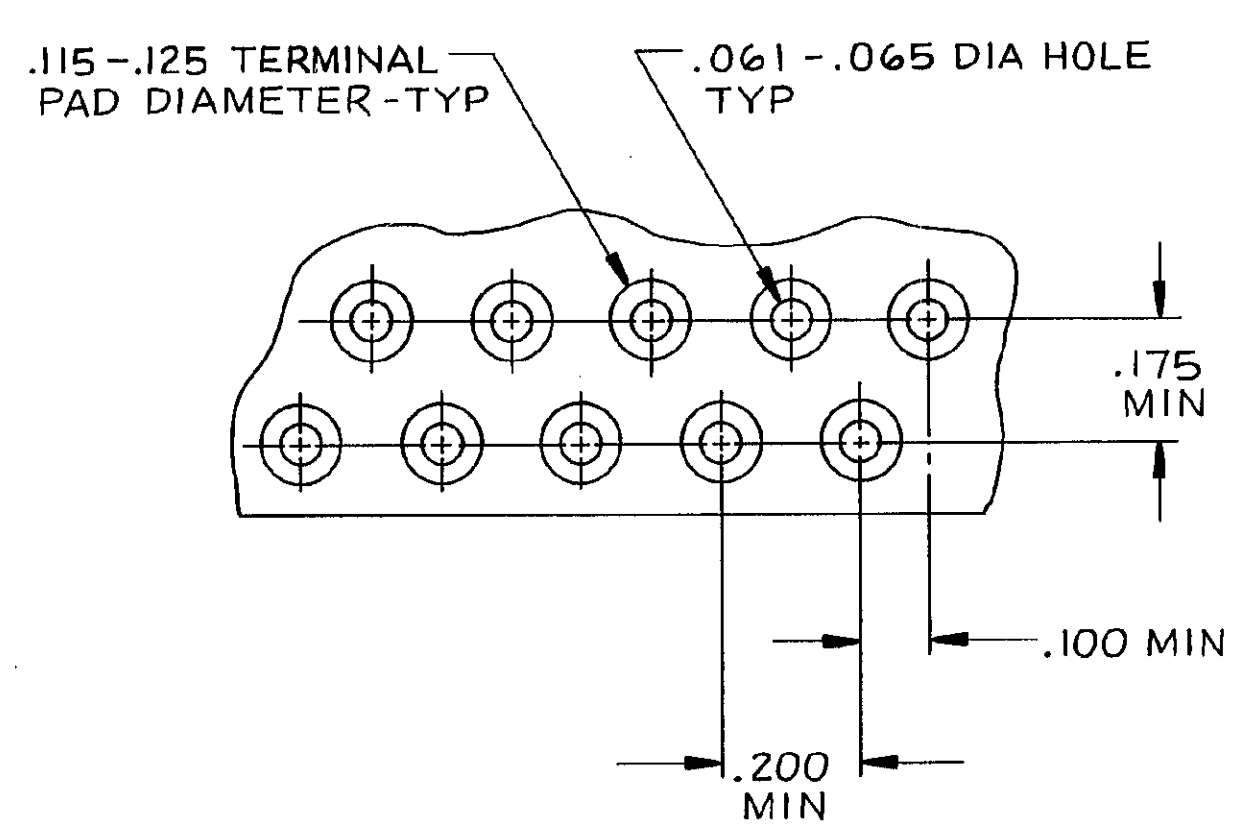

SUGGESTED PRINTED CIRCUIT BOARD
MOUNTING DIMENSIONS
SCALE - NTS

OBSOLETE	230549-1	LOOSE PIECE △	AS SHOWN WITH DETAIL A	-3
OBSOLETE	1-453973-4	STRIP MOUNTED	AS SHOWN	-2
OBSOLETE	230549-1	LOOSE PIECE △	AS SHOWN	554935-1
TERMINAL INSERTION TOOL		DESCRIPTION		PART NO
UNLESS OTHERWISE SPECIFIED DIMENSIONS ARE IN INCHES. TOLERANCES ON: DECIMALS ± ANGLES ±		CONTRACT NO		
MATERIAL		DR <i>Shultz</i> 8-21-86		
PHOS BRONZE		CHK <i>A. Fox</i> 8-25-86		
FINISH		APPD <i>Steve Keller</i> 8/25/86		
PRE-TINNED		APPD <i>J. J. Harrison</i> 8/25/86		
OTHER APPD		SIZE	FSCM NO	DRAWING NO
		D	00779	554935
		SCALE 10:1	SHEET 1 OF 1	