

REVISIONS			
REV.	DESCRIPTION	DATE	APPROVED
A	INITIAL RELEASE	10/01/08	M.J.

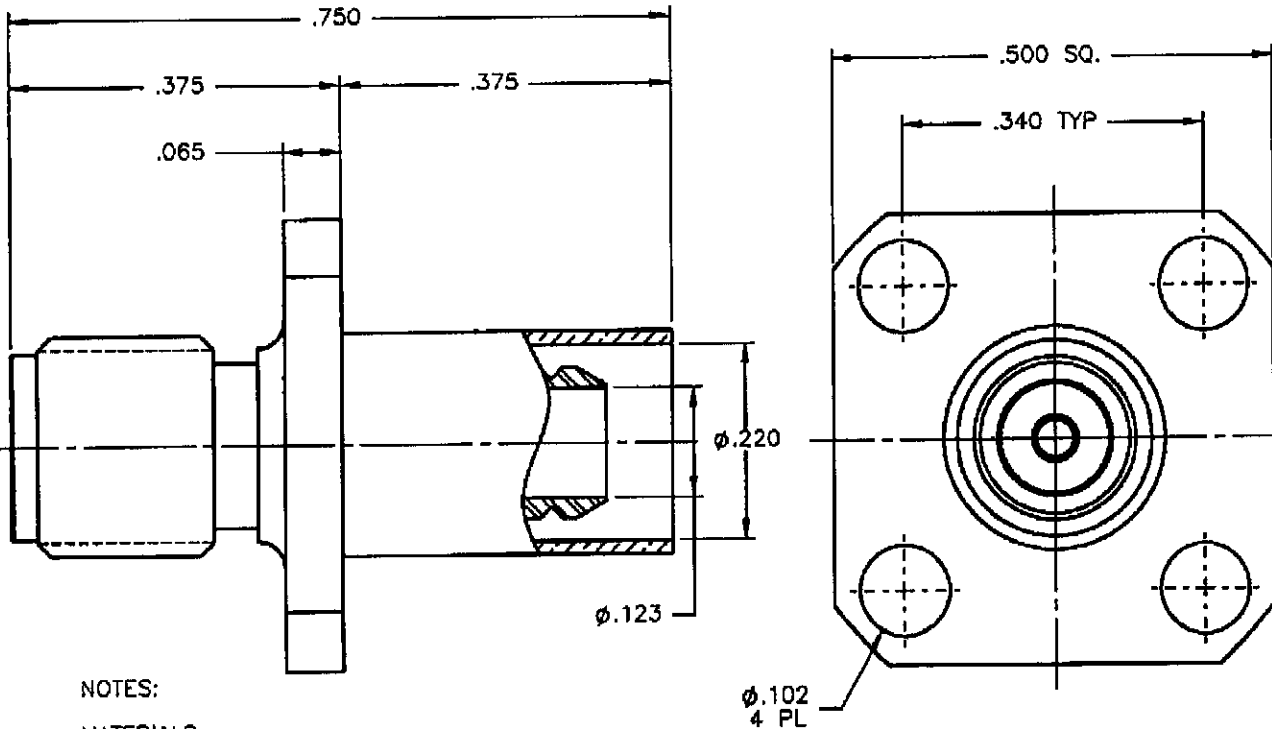

NOTES:

MATERIALS:

1. BODY = STAINLESS STEEL PER ASTM A582, ALLOY 303, CONDITION "A".
2. INSULATOR = VIRGIN WHITE TEFLON PER ASTM D1710, GRADE 1, TYPE I, CLASS "B".
3. CONTACT = BERYLLIUM COPPER PER ASTM B196, ALLOY C17300, TEMPER TD04.
4. CRIMP SLEEVE = SEAMLESS LOWLEAD BRASS TUBE, ALLOY 330, SOFT ANNEAL TEMPER, .025/.060 GRAIN SIZE OR SEAMLESS COPPER TUBE PER ASTM B75, TYPE C12000, TEMPER: LIGHT ANNEAL O50 EXCEPT YIELD STRENGTH.
5. SHRINK SLEEVE = THERMOFIT SCL, BLACK (NOT SHOWN).

FINISHES:

1. BODY = GOLD PLATE PER MIL-G-45204, TYPE II, CLASS 0, GRADE C, OVER .000050 TO .00010 STRESS FREE NICKEL PER QQ-N-290.
2. CONTACT = GOLD PLATE PER MIL-G-45204, TYPE II, CLASS 1, GRADE C, OVER .00010 TO .00020 STRESS FREE SULFAMATE NICKEL PER QQ-N-290.
3. CRIMP SLEEVE = GOLD PLATE PER MIL-G-45204, TYPE II, CLASS 0, GRADE C, OVER .00010 TO .00020 COPPER STRIKE PER MIL-C-14550.

Property of Radiall Incorporated
 This document cannot be reproduced or
 communicated to a third party without prior
 written permission of RADIALL Incorporated.

9031-1023-001

UNLESS OTHERWISE SPECIFIED DIMENSIONS ARE IN INCHES TOLERANCES ON	DWN:	DATE	
	M.J.	10/01/08	
	CHKD:	DATE	
DECIMAL	ANGLE	A.D.M.	10/01/08
		APVD:	DATE
		J.M.	10/01/08
REFERENCE:	MATERIALS & FINISHES:		
ORIGINATED: M.J.	SEE NOTES		
DATE: 10/01/08			

APPLIED ENGINEERING PRODUCTS 104 John W. Murphy Dr. New Haven, CT 06513			
SMA STRAIGHT JACK 4 HOLE FLANGE/CRIMP TYPE FOR RG-55 & SIMILAR CABLES			
SIZE	FSCM NO.	DWG NO.	REV
A	19505	9031-1023-001	A
SCALE 5:1		THIRD ANGLE PROJECTION	SHEET 1 OF 1