



Wireless Power Transfer

Tx Coil Units (WPC Compliant)

WT505090-10F2-LP-G1

Wireless Power Transfer

Tx Coil Units (WPC Compliant)



WT505090-10F2-LP-G1

FEATURES

- Designed based on WPC (Qi) technology
- Using high performance TDK magnetic material

APPLICATIONS

- Consumer charger
- Industrial, medical and automotive products

SHAPE & DIMENSIONS

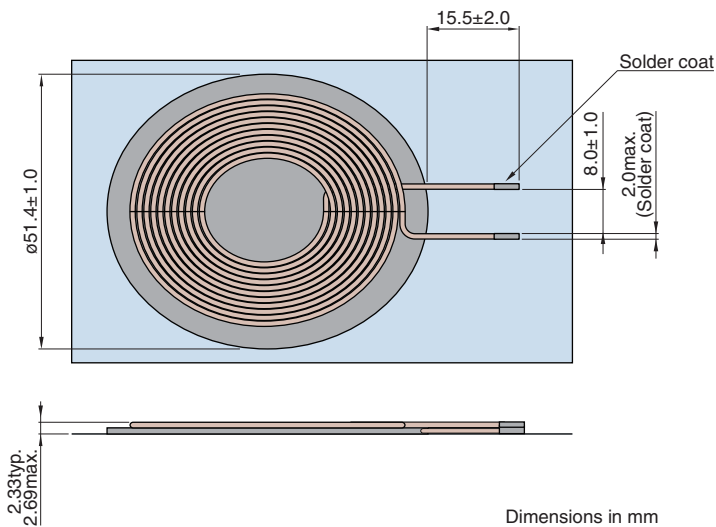

AIR COIL SPECIFICATIONS

Number of Coils	Wire Diameters	Coil Turns
1	$\phi 0.08 \text{ mm} \times 105 \text{ strands}$	10 / layer, total 1 layer

○ Description of icons: See the following for more details. <https://product.tdk.com/info/en/environment/icon.html>

- All specifications are subject to change without notice.
- Before using these products, be sure to request the delivery specifications.

WT505090-10F2-LP-G1

MAXIMUM RATINGS

Operating Temperature / Humidity	Storage Temperature / Humidity
-30 to +70°C / 10 to 95% R.H.	-40 to +85°C / 10 to 95% R.H.

ELECTRICAL CHARACTERISTICS

Inductance [100kHz] (μ H)	Resistance [100kHz] (Ω)	WPC Compliant
6.3 \pm 10%	0.06 max.	Yes

Test Environment :

Test Instrument : HP 4284A DIGITAL LCR METER or EQUIVALENT

Ambient Temperature : 15 to 35 °C

Relative Humidity : 25 to 75 %R.H.

IC INFORMATIONS

IC	Manufacturer
P9035	IDT (Integrated Device Technology)
TS8000	Semtech
TB6865AFG	TOSHIBA
P9035A	IDT (Integrated Device Technology)
LTC4120	Analog Devices (Linear Technology)
MWCT1000	NXP

* Please contact us for more detail.

PACKAGING : BOX TYPE

Dimensions (mm)		Quantity (pcs)	
Tray	—	Qty per tray	—
Small carton	131x118.5x85	Qty per small carton	80
Outer carton	276x170x109	Qty per outer carton	160

OTHERS

Weight (g) typ.
14

- All specifications are subject to change without notice.
- Before using these products, be sure to request the delivery specifications.

 **Reminders**

- Do not use or store in locations where there are conditions such as gas corrosion (salt, acid, alkali, etc.).
- Self heating (temperature increase) occurs when the power is turned ON, so the tolerance should be sufficient for the set thermal design.
- Fully caution, if metal piece contacted with top of coil surface then it could be danger of generated heat.
- Do not use for a purpose outside of the contents regulated in the delivery specifications.
- The products listed on this catalog are intended for use in general electronic equipment (AV equipment, telecommunications equipment, home appliances, amusement equipment, computer equipment, personal equipment, office equipment, measurement equipment, industrial robots) under a normal operation and use condition.

The products are not designed or warranted to meet the requirements of the applications listed below, whose performance and/or quality require a more stringent level of safety or reliability, or whose failure, malfunction or trouble could cause serious damage to society, person or property.

If you intend to use the products in the applications listed below or if you have special requirements exceeding the range or conditions set forth in the each catalog, please contact us.

- | | |
|---|--|
| (1) Aerospace/aviation equipment | (8) Public information-processing equipment |
| (2) Transportation equipment (cars, electric trains, ships, etc.) | (9) Military equipment |
| (3) Medical equipment | (10) Electric heating apparatus, burning equipment |
| (4) Power-generation control equipment | (11) Disaster prevention/crime prevention equipment |
| (5) Atomic energy-related equipment | (12) Safety equipment |
| (6) Seabed equipment | (13) Other applications that are not considered general-purpose applications |
| (7) Transportation control equipment | |