

May.1.2023 Copyright 2023 HIROSE ELECTRIC CO., LTD. All Rights Reserved.
In case of consideration for using Automotive equipment / device which demand high reliability, kindly contact our sales window correspondents.

Notes. 1. Recommended cable condition is shown below.
 ⚠ A list of compatible cables is available on the Hirose website.
 When using a non-recommended cable, please contact a Hirose sales representative.
 Refer to the technical specification (ETAD-E3213) for wiring and assembly procedures.

⚠ Recommended Cable

Items		⚠ Recommended Condition
Conductor	Size	AWG#24 to 25
	Composition	7 stranded
	Material	Annealed copper wire
Insulation O. D.		φ 1.1~1.25mm
Braid Shield		Tin plating
Sheath O. D.		φ 6.3~7.2mm

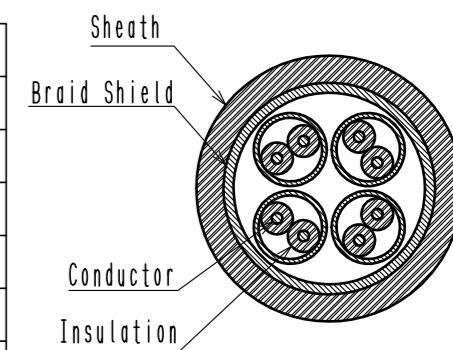

2. This product (Type B) is used for non Ethernet applications like signaling, serial or other industrial bus communication systems. Please use Type A for 10/100 Mbit/s and 1/10 Gbit/s Ethernet communication.

⚠ Mating Key

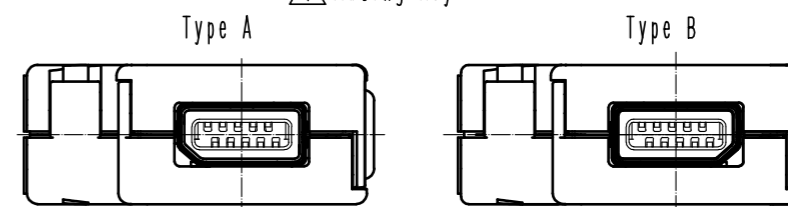

⚠ 3 Excluding the plug unit, this product is packaged separately by the type of parts. The shield shell is packaged prior to bending. (See next page.) Refer to the technical specification (ETAP-E3224) for packing.

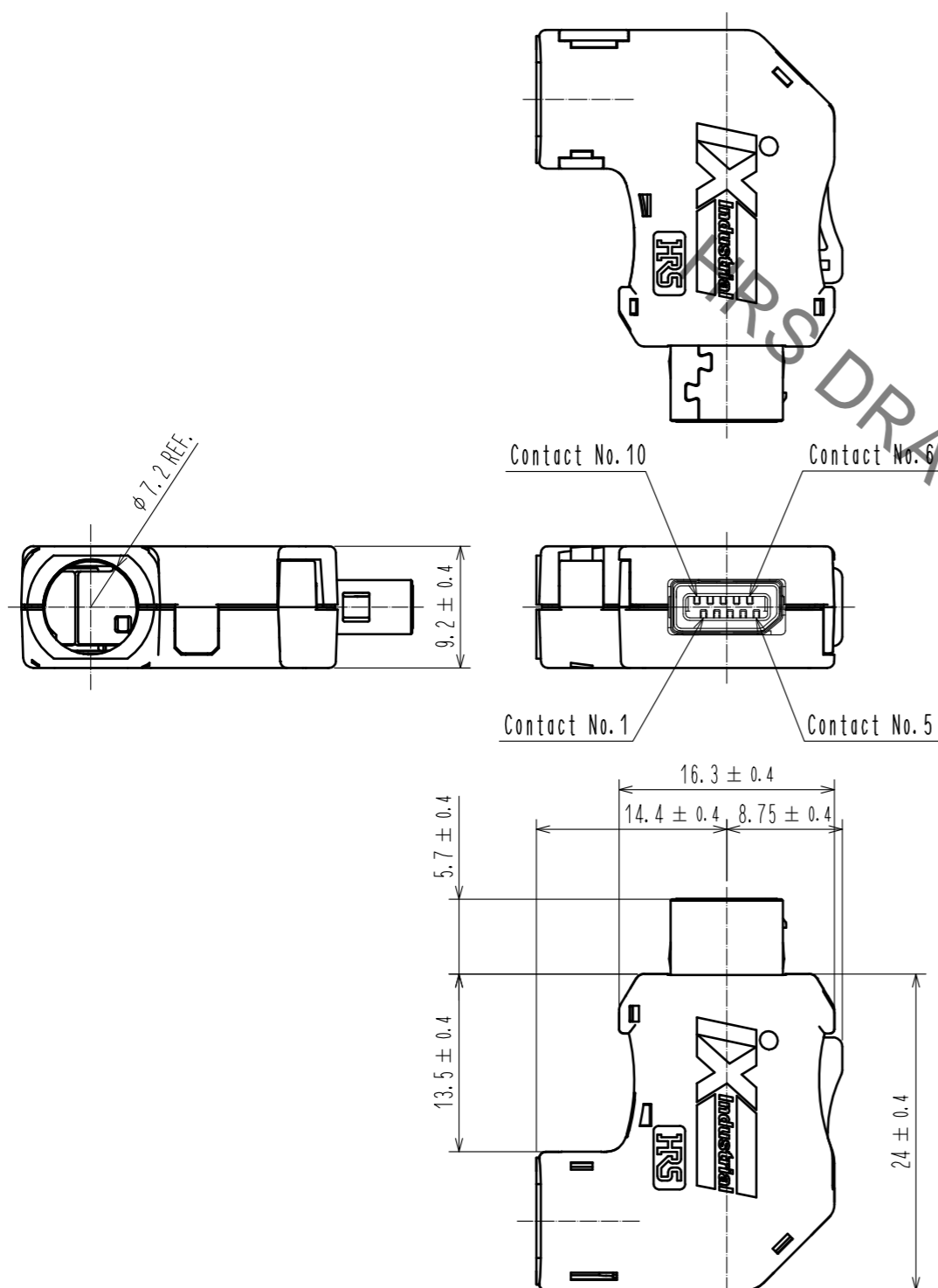

NO.	MATERIAL	FINISH .	REMARKS	NO.	MATERIAL	FINISH .	REMARKS
4	PA		Black, UL94V-0	9	PC		Dark gray, UL94V-0
3	Stainless Steel			8	PC		Dark gray, UL94V-0
2	PA		Dark gray, UL94V-0	7	Stainless Steel		Nickel 0.2 μm min
1	Copper Alloy	Contact area : Palladium-Nickel 0.75 μm min + Gold 0.05 μm min		6	Stainless Steel		Nickel 1 μm min
		Wiring area : Gold 0.03 μm min		5	PC		Clear yellow, UL94V-0
		Under plating : Nickel 2 μm min					

UNITS	SCALE	COUNT	DESCRIPTION OF REVISIONS	DESIGNED	CHECKED	DATE
mm	2 : 1	6	DIS-E-00006881	MT. YASUDA	KI. KAGOTANI	20211025

APPROVED	NO.	DRAWING NO.
APPROVED : MN. KENJO	20200519	EDC-129980-01-00
CHECKED	NO.	PART NO.
CHECKED : KI. NAGANUMA	20200519	IX31G-B-10S-CVL1(7.0)(01)
DESIGNED	NO.	CODE NO.
DESIGNED : MT. YASUDA	20200519	CL0251-0068-0-01
DRAWN	NO.	
DRAWN : MY. KOMUKAI	20200519	

May.1.2023 Copyright 2023 HIROSE ELECTRIC CO., LTD. All Rights Reserved.
 In case of consideration for using Automotive equipment / device which demand high reliability, kindly contact our sales window correspondents.

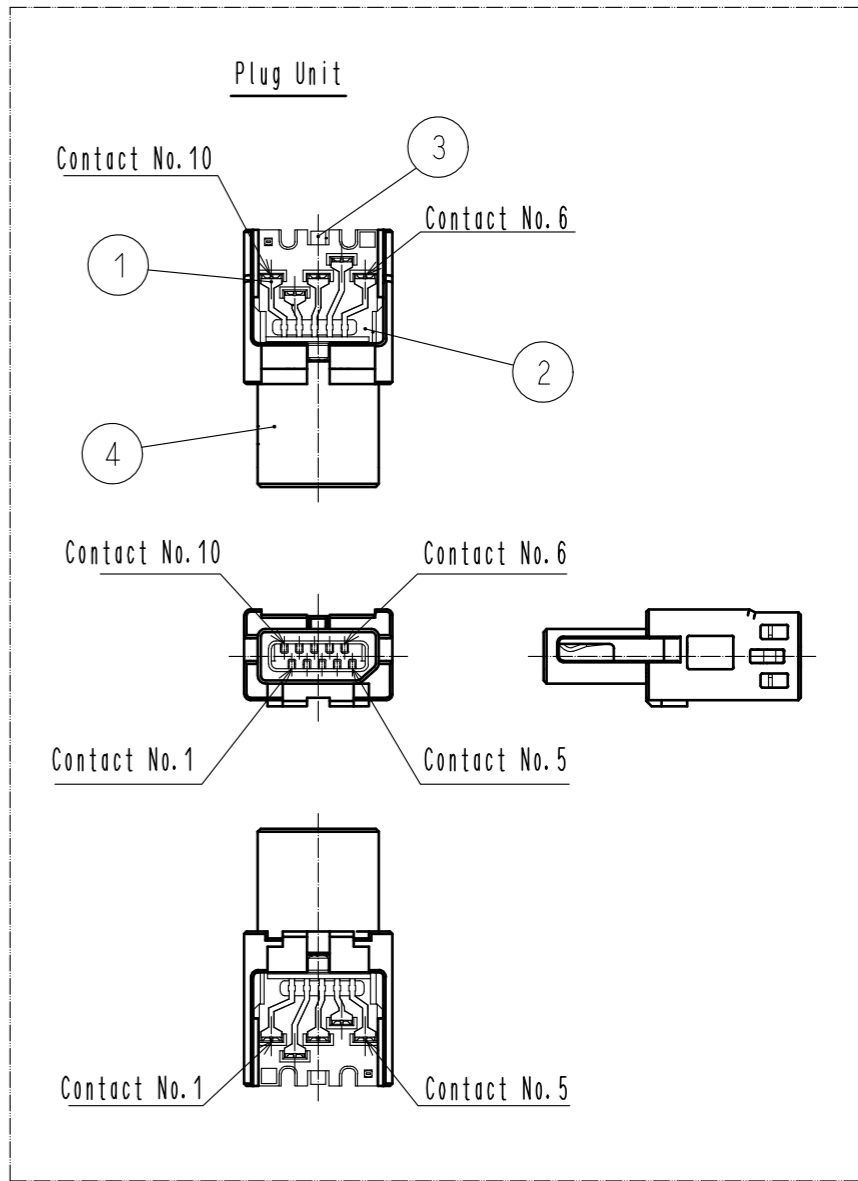
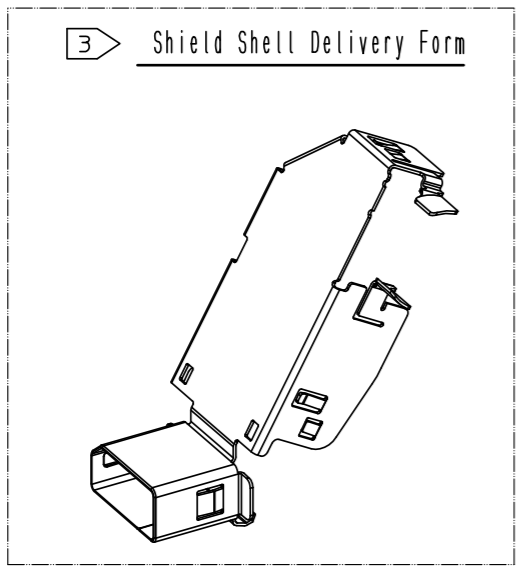
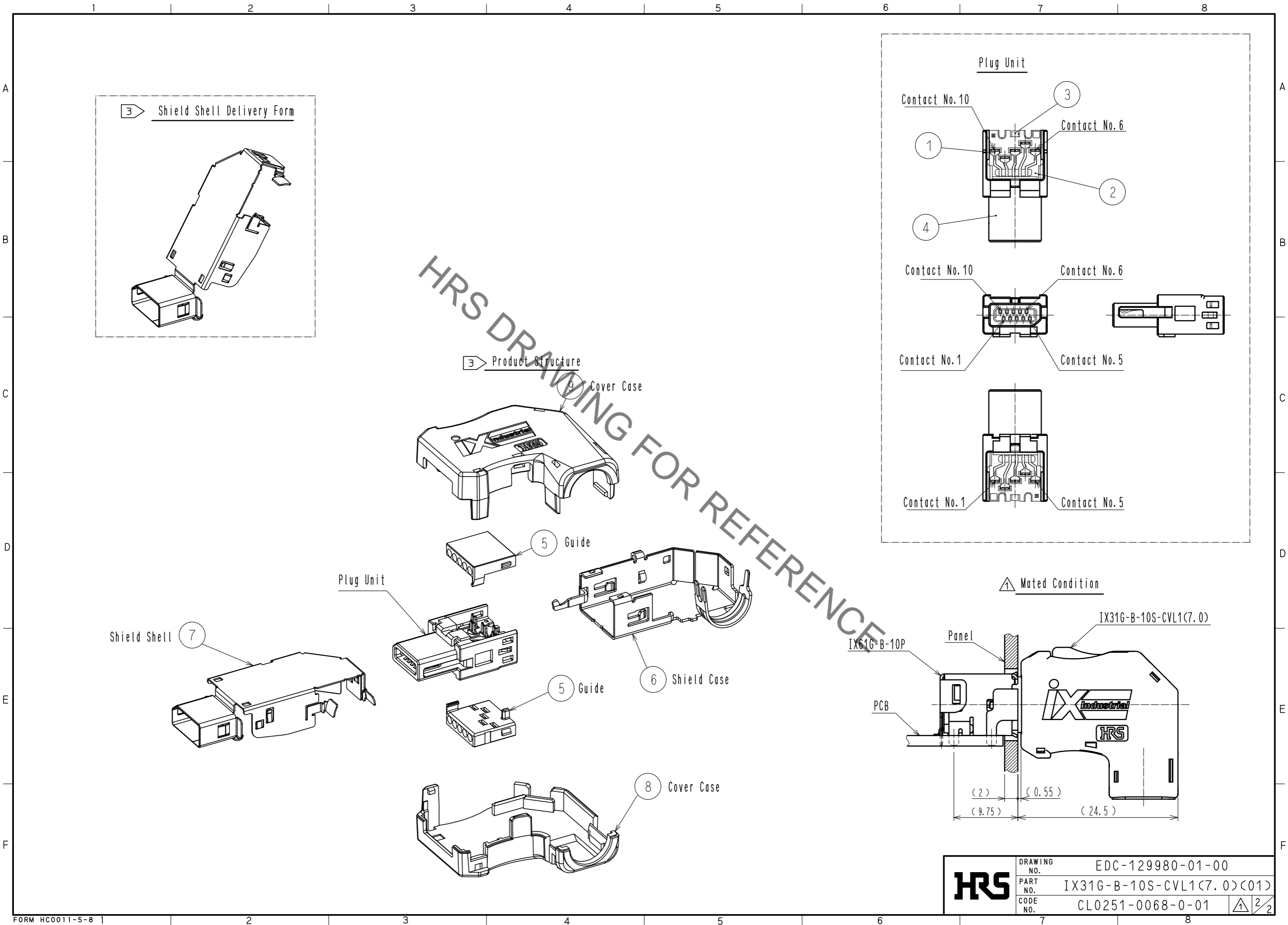

△ Mated Condition

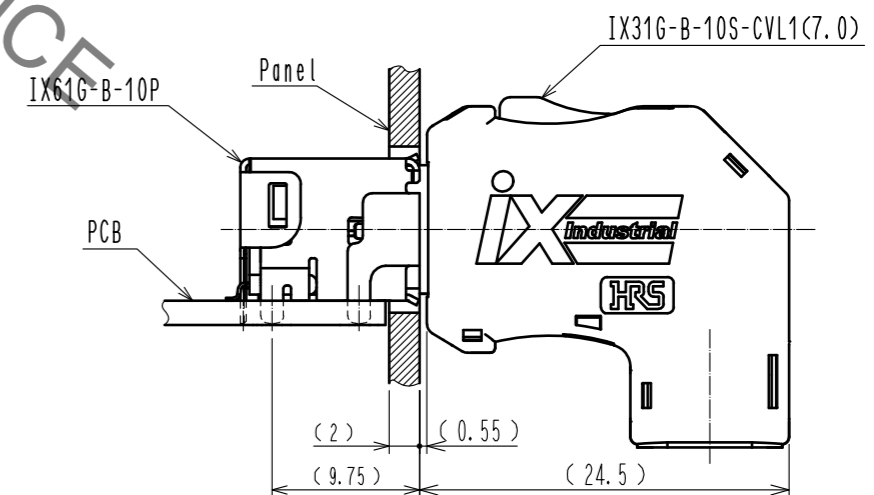

HRS	DRAWING NO.	EDC-129980-01-00
	PART NO.	IX31G-B-10S-CVL1(7.0)(01)
	CODE NO.	CL0251-0068-0-01
		△ 2/2