

REV. B	SHEET 1 OF 3	10-504639-007
M REVISIONS		
LTR	DESCRIPTION	DATE
A	PRODUCTION RELEASE	6/21/18
B	CL(11) SEE CHANGE NOTICE ECN: D0089	11/1/19

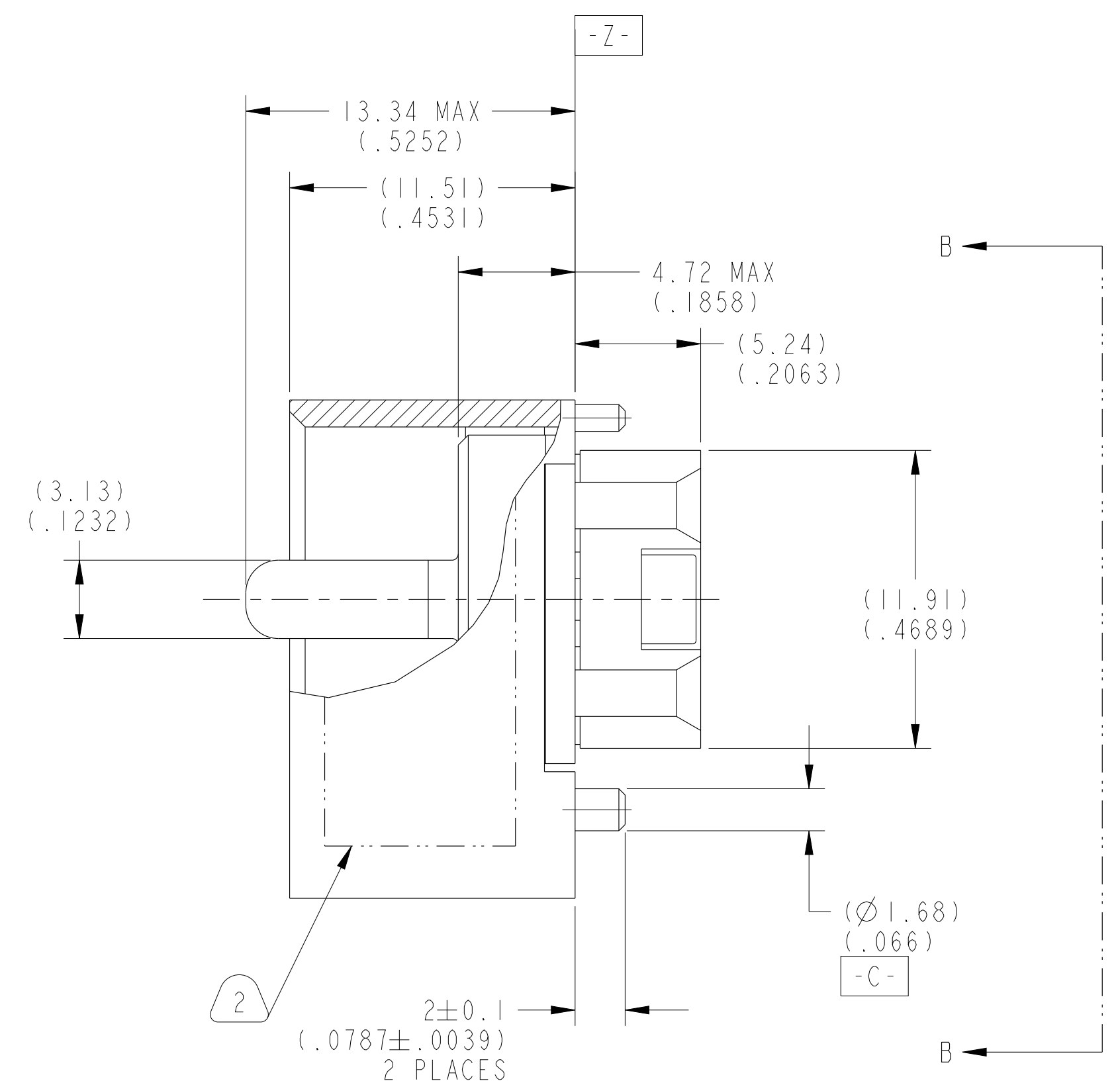
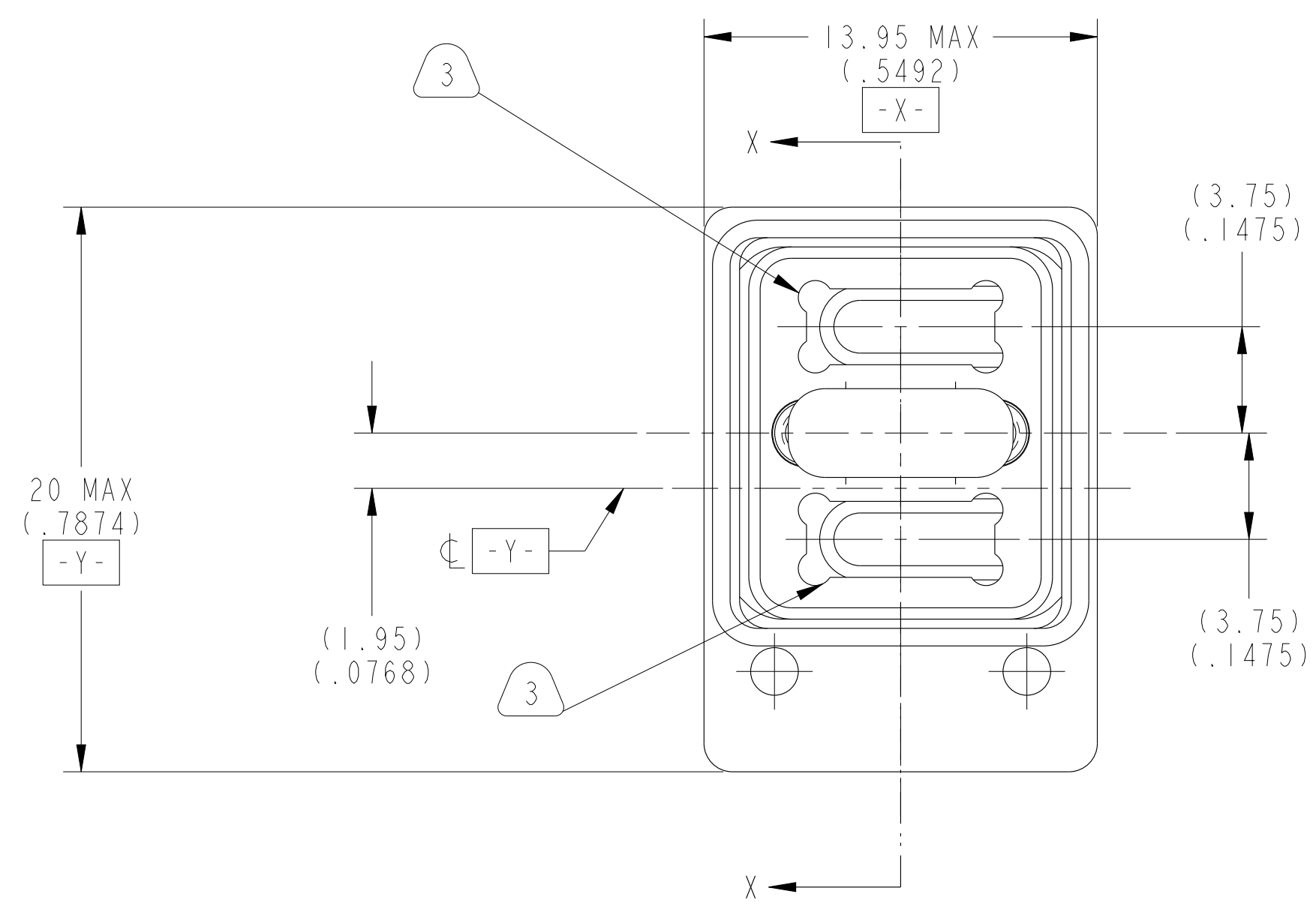
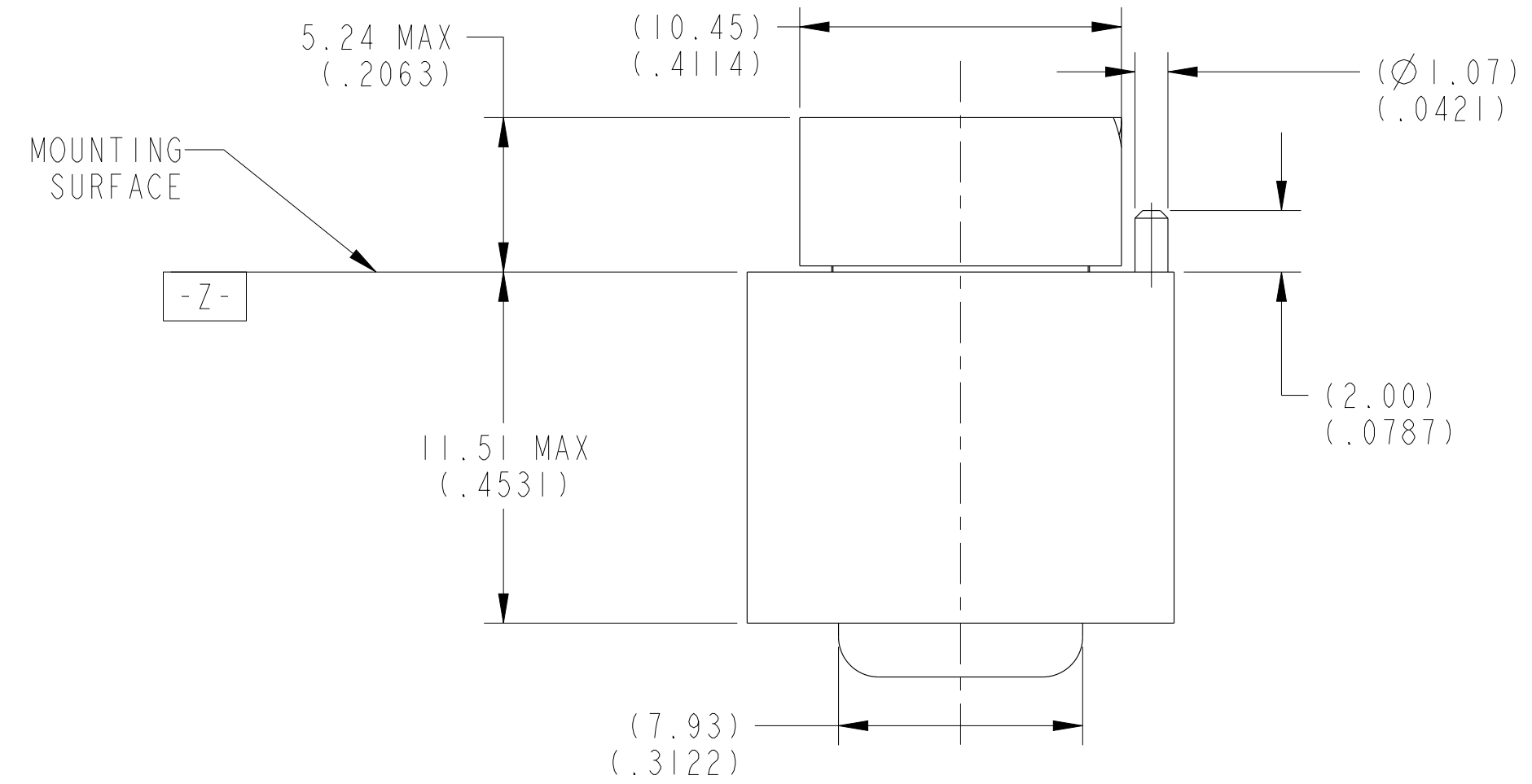

**SECTION X-X**  
**METRIC DRAWING**

SEE SHEET 2

**NOTES:**  
THE USE OF THIS DOCUMENT IS UNLIMITED. HOWEVER, DOCUMENTS REFERENCED HEREON MAY CONTAIN LIMITED RIGHTS DATA.

SCALE 5.000

UNLESS OTHERWISE SPECIFIED	SPECIFICATIONS	POS	QTY	PART NUMBER	DESCRIPTION	NOTE
LINEAR DIMENSIONS ARE IN MILLIMETERS TOLERANCES: (INCHES) .XXXX = ±NA ANGLES= ±2° .XXX = ±NA .XX = ±.13 .X = ±.25 DIM. & TOL. PER ASME Y14.5M; DRM PER MIL-DTL-31000; OTHER Amphenol Sids. PER 9-3800 LEGENDS: =FLAG NOTE CALL OUT REFERENCE ONLY	MATERIAL SPEC.	PARTS LIST				
	NONE	<b>AMPHENOL CORPORATION</b> 40-60 DELAWARE AVENUE SIDNEY, N.Y. 13838 <b>CONNECTOR, FIBER OPTIC, BACKPLANE,            2 MT SPECIAL            (VITA 66.4 ENVELOPE)</b>				
PROCESS SPEC.	9-3895 9-3856-5	APPROVALS PREPARED BY R. CHAPMAN ENGINEER IN CHARGE E. HICKEY DESIGN MANAGER R. SELFRIDGE DESIGN ACTIVITY GROUP BLP 23-Jun-17		DATE	SIZE C CAGE CODE 77820 DOCUMENT NO. 10-504639-007 REF: 10-504639-006 SHEET 1 OF 3	

NONE	PRO/ENGINEER INFORMATION
NEXT ASSEMBLY	Pro/e Model Used: 10-504639-007.DWG.ASSEM Drawing Name: 10-504639-007

10-504639-007 DOCUMENT NO. SHEET 1 OF 3 REV. B

10-504639-007 DOCUMENT NO. SHEET 1 OF 3 REV. B

10-504639-007

SHEET 2 OF 3

REV. B

C

B

A

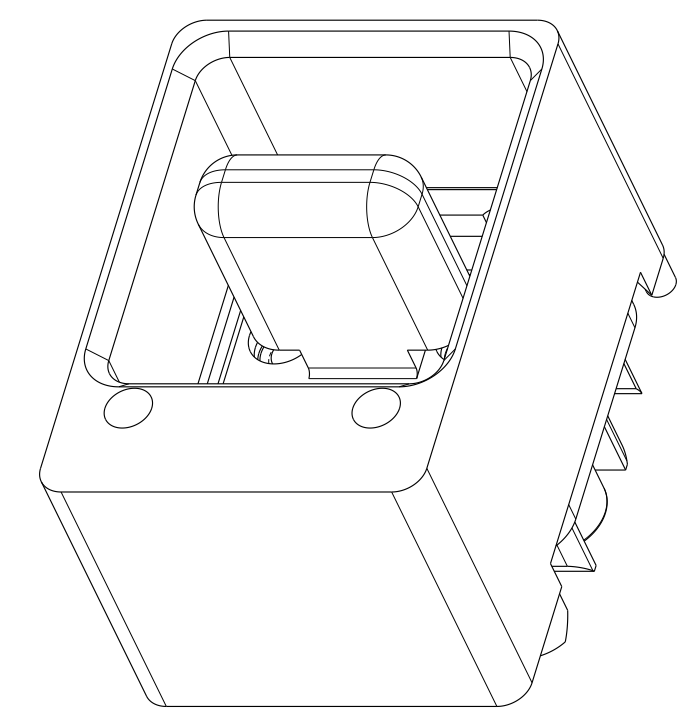
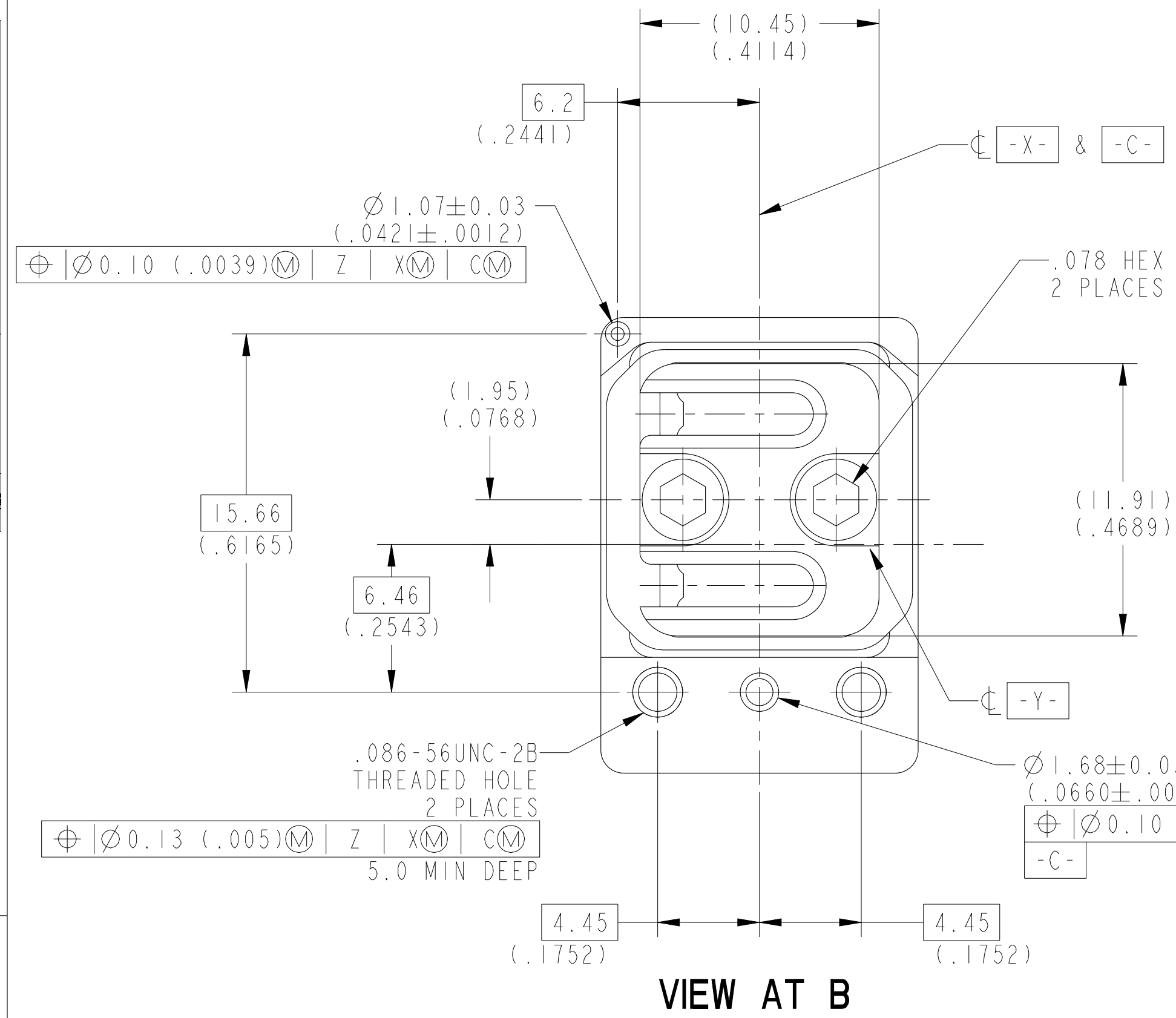

**TOP ISO VIEW**  
 SCALE 4.000

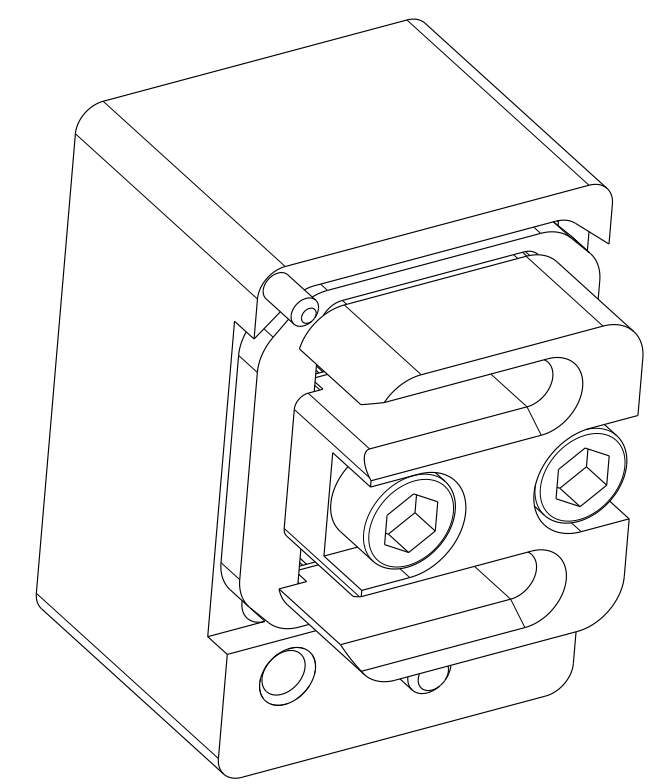

**BOTTOM ISO VIEW**  
 SCALE 4.000

**VIEW AT B**

7. FOR CONNECTOR INSTALLATION ILLUSTRATION SEE SHEET 3.
6. FOR MATING MODULE CONNECTOR ASSEMBLY, SEE DRAWING 10-504637-009.
5. TIGHTEN CAPTIVE SCREWS TO 2-3 IN-LBS AFTER INSTALLING MT FERRULE (NOT INCLUDED).
4. FIBER OPTIC INSERT IS DESIGNED FOR MT TYPE FERRULES TERMINATED TO NON-STRENGTH MEMBERED RIBBON CABLE.
3. INDICATED CAVITIES WILL ACCOMODATE A STANDARD 12 CHANNEL MT FERRULE PER IEC 61754-5 (SEE NOTE 4).
2. BLACK INK STAMP "APH" 77820 PART NUMBER AND DATE CODE ON INDICATED SURFACE PER 9-3856-5. DATE CODE PER 9-3895. CHARACTERS TO BE 1.6±.51 (.062±.020) HIGH. ADDITIONAL INFORMATION MAY BE REQUESTED BY PURCHASE ORDER.
1. PARTS ARE SHIPPED UNASSEMBLED.

**MATERIALS AND FINISHES**

COMPONENT	MATERIAL/ FINISH
BACKPLANE SHELL	BODY - MATERIAL - ALUM. ALLOY PER AMS 4150 FINISH - CHROMATE TREATMENT PER MIL-C-5541, CL 3
INSERT ASSEMBLY	FRONT INSERT/RETAINER - MATERIAL - ALUM ALLOY PER AMS 4150 FINISH - CHROMATE TREATMENT PER MIL-C-5541, CL3 SCREW - STAINLESS STEEL 300 SERIES, PASSIVATED HELICAL INSERTS - STAINLESS STEEL 300 SERIES, PASSIVATED

THE USE OF THIS DOCUMENT IS UNLIMITED.  
 HOWEVER, DOCUMENTS REFERENCED HEREON  
 MAY CONTAIN LIMITED RIGHTS DATA.

SIZE <b>C</b>	CAGE CODE <b>77820</b>	DOCUMENT NO. <b>10-504639-007</b>	REV. <b>B</b>
SCALE: 3.0	REF. 10-504639-006	SHEET 2 OF 3	

REV. B  
SHEET 2 OF 3

10-504639-007

A

10-504639-007

SHEET 3 OF 3

REV. B

C

B

A

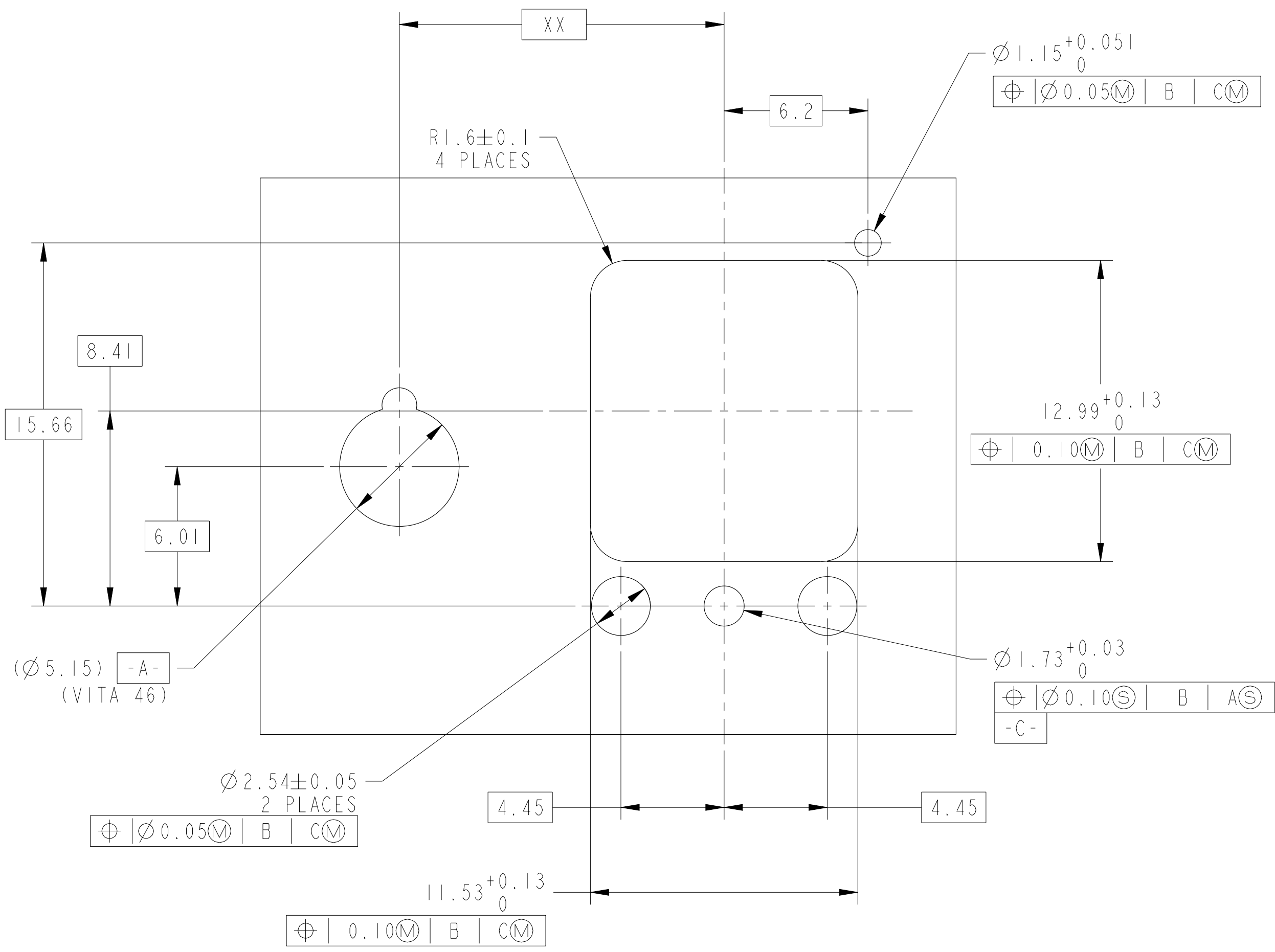

**SUGGESTED BACKPLANE BOARD CUTOUTS**  
 (CONNECTOR SIDE SHOWN)  
 SCALE 6.000

CONNECTOR LOCATION	
POSITION	DIMENSION "XX"
J2A	58.73
J2B	72.85
J3A	101.60
J3B	115.72
J4A	130.40
J4B	144.52
J5A	159.20
J5B	173.32
J6A	188.00
J6B	202.12

THE USE OF THIS DOCUMENT IS UNLIMITED.  
 HOWEVER, DOCUMENTS REFERENCED HEREON  
 MAY CONTAIN LIMITED RIGHTS DATA.

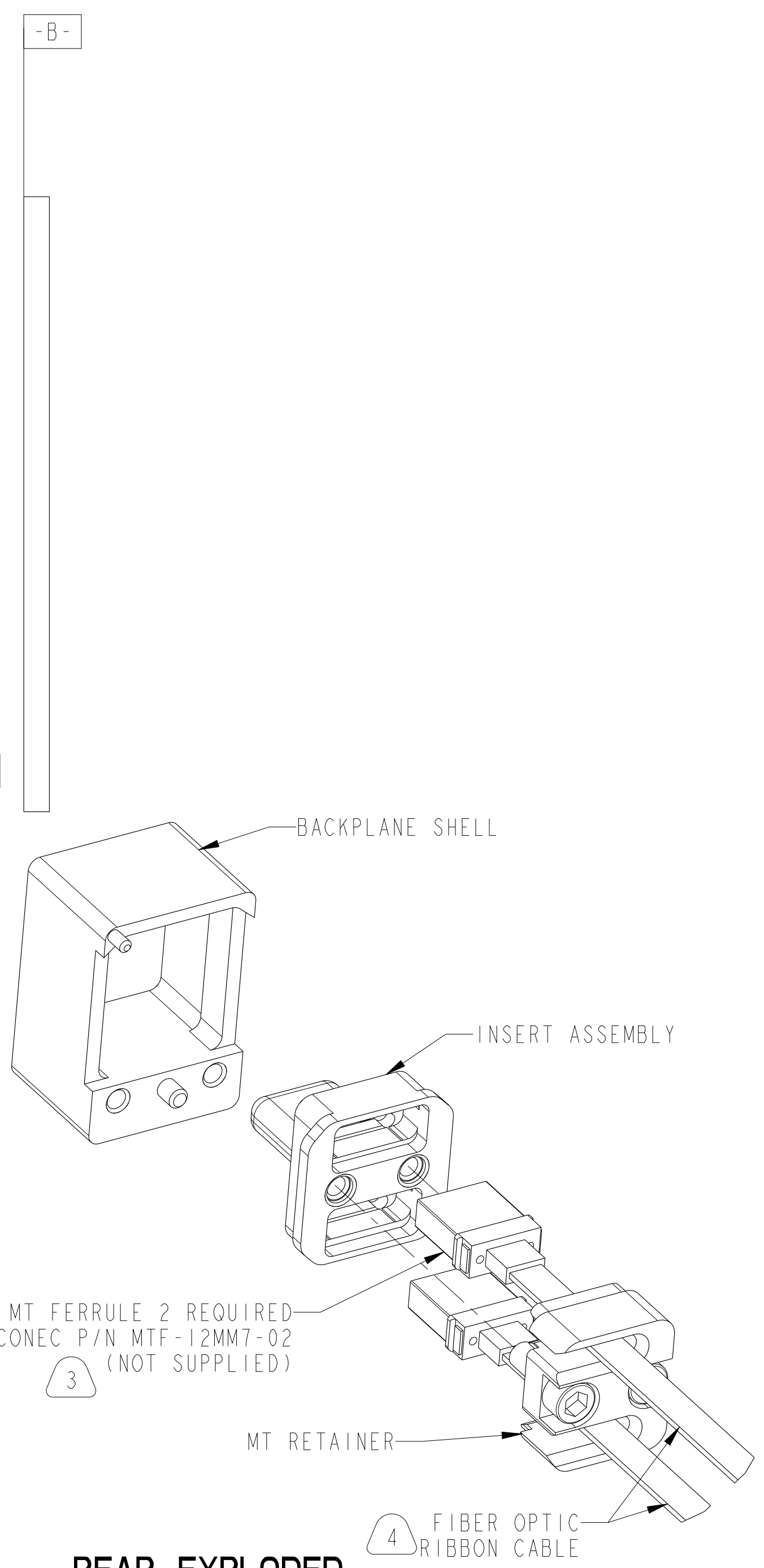

**REAR EXPLODED ASSEMBLY VIEW**  
 SCALE 3.000

SIZE <b>C</b>	CAGE CODE <b>77820</b>	DOCUMENT NO. <b>10-504639-007</b>	REV. <b>B</b>
SCALE: 3.0	REF. 10-504639-006	SHEET 3 OF 3	

D

C

B

SHEET 3 OF 3

10-504639-007

A