

Apr.1.2023 Copyright 2023 HIROSE ELECTRIC CO., LTD. All Rights Reserved.
In case of consideration for using Automotive equipment / device which demand high reliability, kindly contact our sales window correspondents.

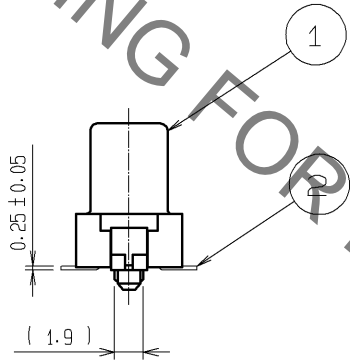

RECOMMENDED LAND PATTERN DIMENSION OF PCB (MOUNTING SIDE)

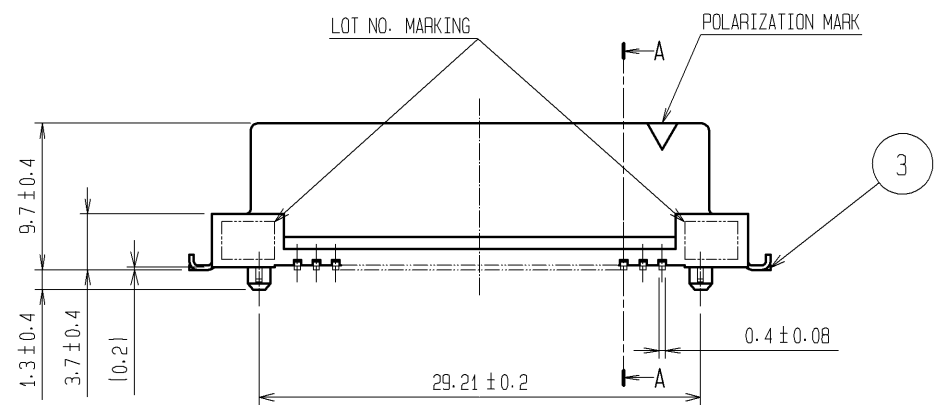
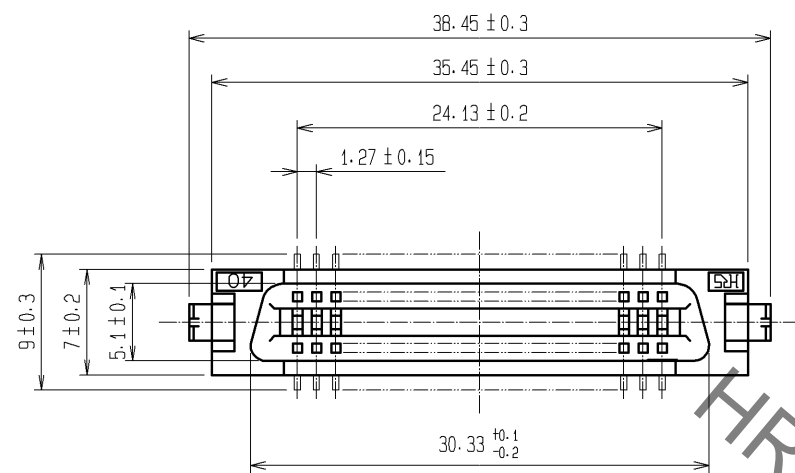
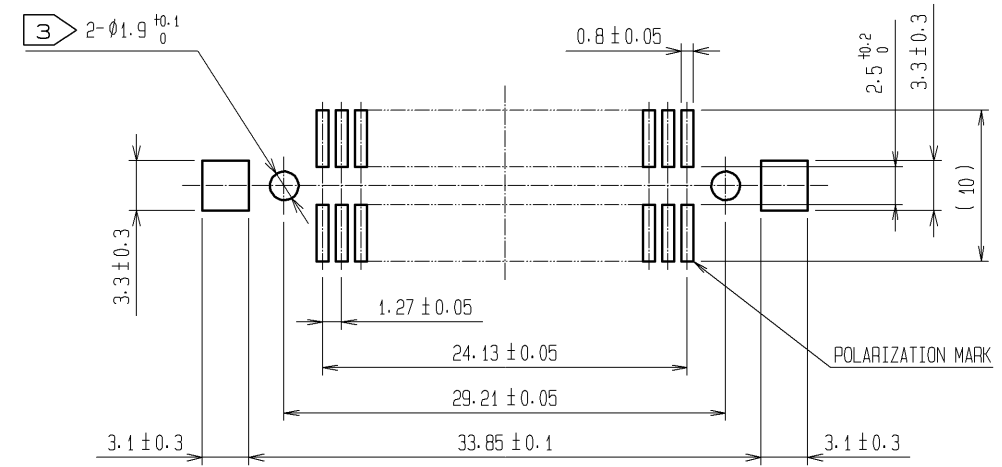

A-A

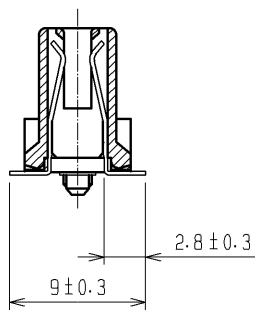
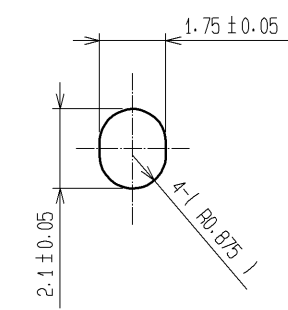
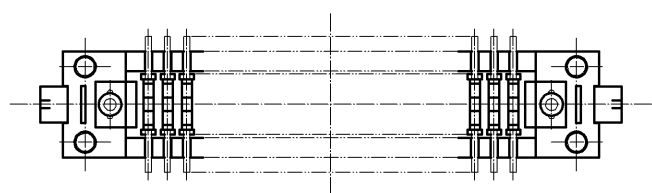

FIG. 1 (5:1)



- NOTES 1 LEAD CO-PLANARITY SHALL BE 0.15 MAX.
2 THE DIMENSIONS IN PARENTHESES ARE FOR REFERENCE.
3 IN CASE OF THE AUTOMATED MOUNTING, RECOMMENDED HOLE DIAMETER OF BOSS IS SHOWN IN FIG. 1.



1	PPS	LIGHT BROWN (UL94V-0)	3	BRASS	TIN-PLATING
			2	PHOSPHOR BRONZE	CONTACT AREA:GOLD 0.2µm min.
					LEAD AREA:TIN-PLATING 2µm min.
					UNDER PLATING:NICKEL 1.5µm min.
NO.	MATERIAL	FINISH . REMARKS	NO.	MATERIAL	FINISH . REMARKS
UNITS	mm	SCALE	2 : 1	COUNT	△
		DESCRIPTION OF REVISIONS	DESIGNED	CHECKED	DATE
		APPROVED : HS. OKAWA	07. 10. 19	DRAWING NO. EDC3-082415-21	
		CHECED : HS. OZAWA	07. 10. 19	PART NO. FX2-40S-1. 27SVL(71)	
		DESIGNED : SY. KAMIGA	07. 10. 19	CODE NO. CL572-2153-7-71	
		DRAWN : HK. SUNADORI	07. 10. 19		