

May.1.2023 Copyright 2023 HIROSE ELECTRIC CO., LTD. All Rights Reserved.
In case of consideration for using Automotive equipment / device which demand high reliability, kindly contact our sales window correspondents.

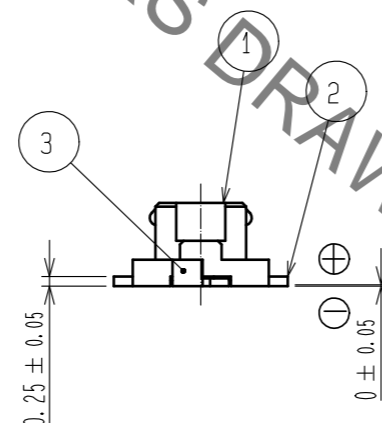

RECOMMENDED METAL MASK (10:1)

RECOMMENDED LAND PATTERN (10:1)

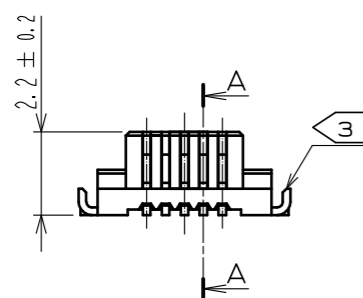
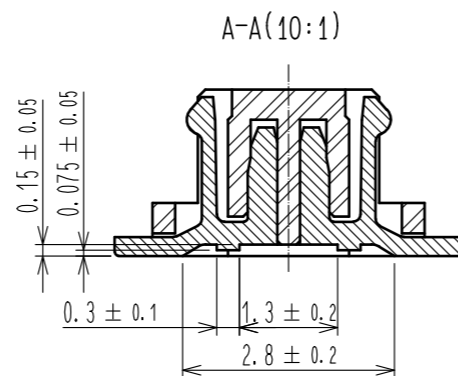
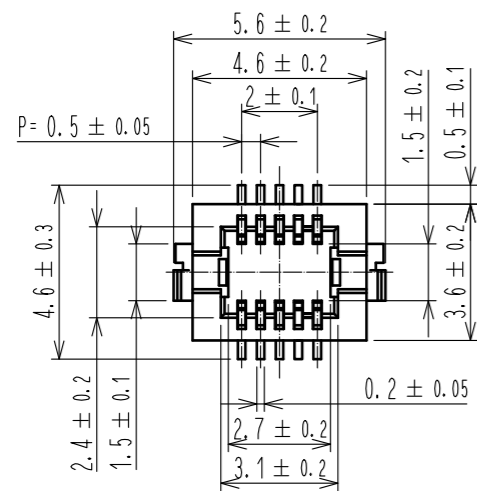
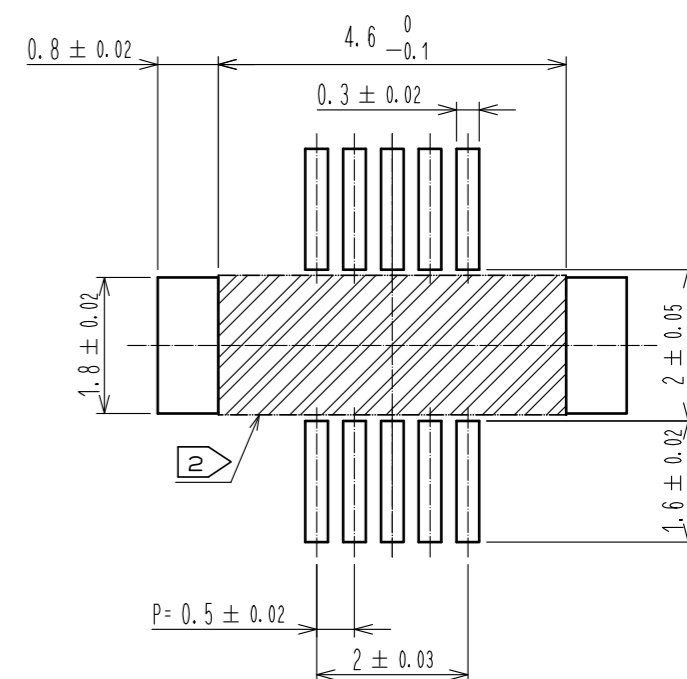
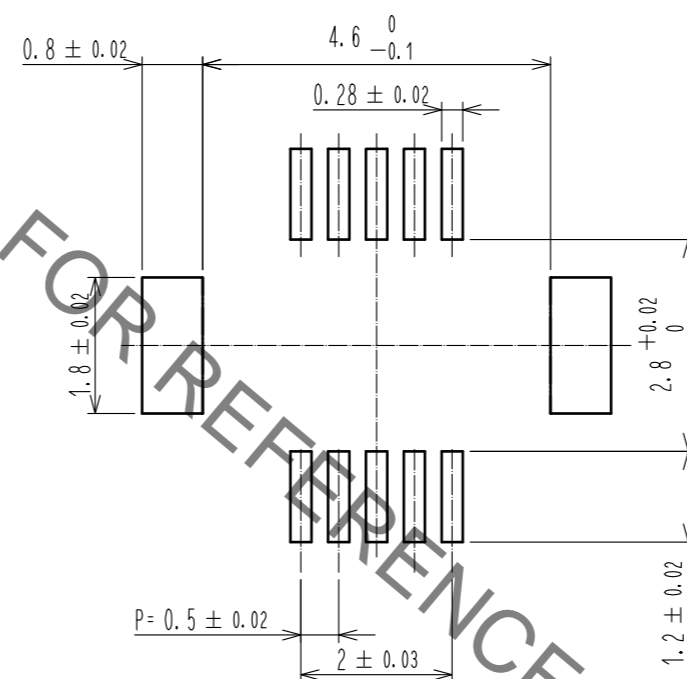

RECOMMENDED THICKNESS OF SOLDER PASTE: 120µm

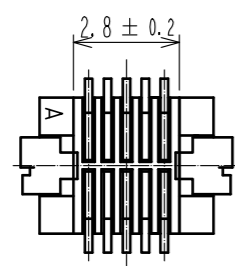

NOTES 1 : LEAD CO-PLANARITY REINFORCED METAL FITTINGS SHALL BE 0.08 mm MAX.

- ② IF THERE IS PATTERN ON PART, THERE IS A POSSIBILITY THAT IT WILL MAKE CONTACT WITH THE LEADS.
- ③ REINFORCED METAL FITTINGS AS FOLLOWS.

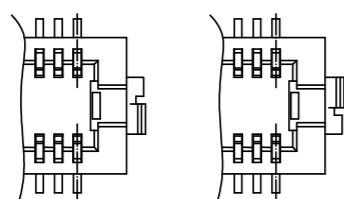

2	PHOSPHOR BRONZE	CONTACT AREA:GOLD PLATED 0.2µm min LEAD AREA:GOLD PLATED 0.015µm min OTHERS(UNDER PLATING):NICKEL PLATED 2µm min	6	PS	BLACK (PLASTIC REEL)
1	POLYAMIDE	UL94V-0, BLACK	5	POLYESTER	CLEAR (COVER TAPE)
			4	PS	CLEAR (EMBOSSED CARRIER TAPE)
			3	BRASS	TIN PLATED 2µm min (UNDER PLATING):NICKEL 1µm min
NO.	MATERIAL	FINISH . REMARKS	NO.	MATERIAL	FINISH . REMARKS
UNITS		SCALE	COUNT	DESCRIPTION OF REVISIONS	
mm		5 : 1		DESIGNED	CHECKED
APPROVED : WR. FUKUCHI 20190828			DRAWING NO. EDC-389243-51-01		
CHECED : TS. MIYAZAKI 20190827			PART NO. DF12NB(3.0)-10DS-0.5V(51)		
DESIGNED : KT. KUSAKA 20190827			CODE NO. CL537-0097-0-51		
DRAWN : KT. KUSAKA 20190827			1/2		

May.1.2023 Copyright 2023 HIROSE ELECTRIC CO., LTD. All Rights Reserved.
 In case of consideration for using Automotive equipment / device which demand high reliability, kindly contact our sales window correspondents.

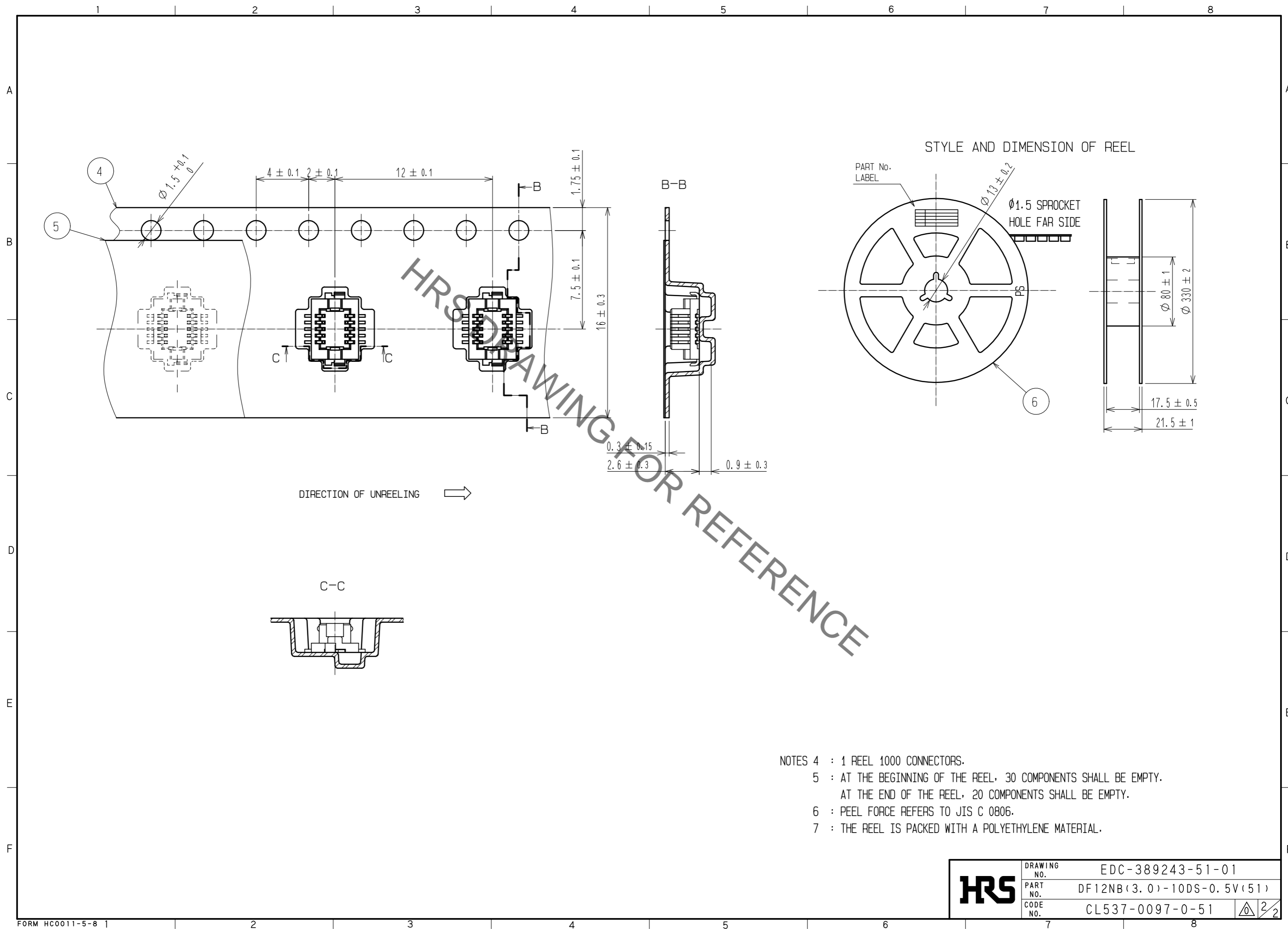

- NOTES 4 : 1 REEL 1000 CONNECTORS.
 5 : AT THE BEGINNING OF THE REEL, 30 COMPONENTS SHALL BE EMPTY.
 AT THE END OF THE REEL, 20 COMPONENTS SHALL BE EMPTY.
 6 : PEEL FORCE REFERS TO JIS C 0806.
 7 : THE REEL IS PACKED WITH A POLYETHYLENE MATERIAL.

HRS	DRAWING NO.	EDC-389243-51-01
	PART NO.	DF12NB(3.0)-10DS-0.5V(51)
	CODE NO.	CL537-0097-0-51
		2/2