

Isometric View
SCALE 3 : 2
Product shipped in clamp
open position as shown

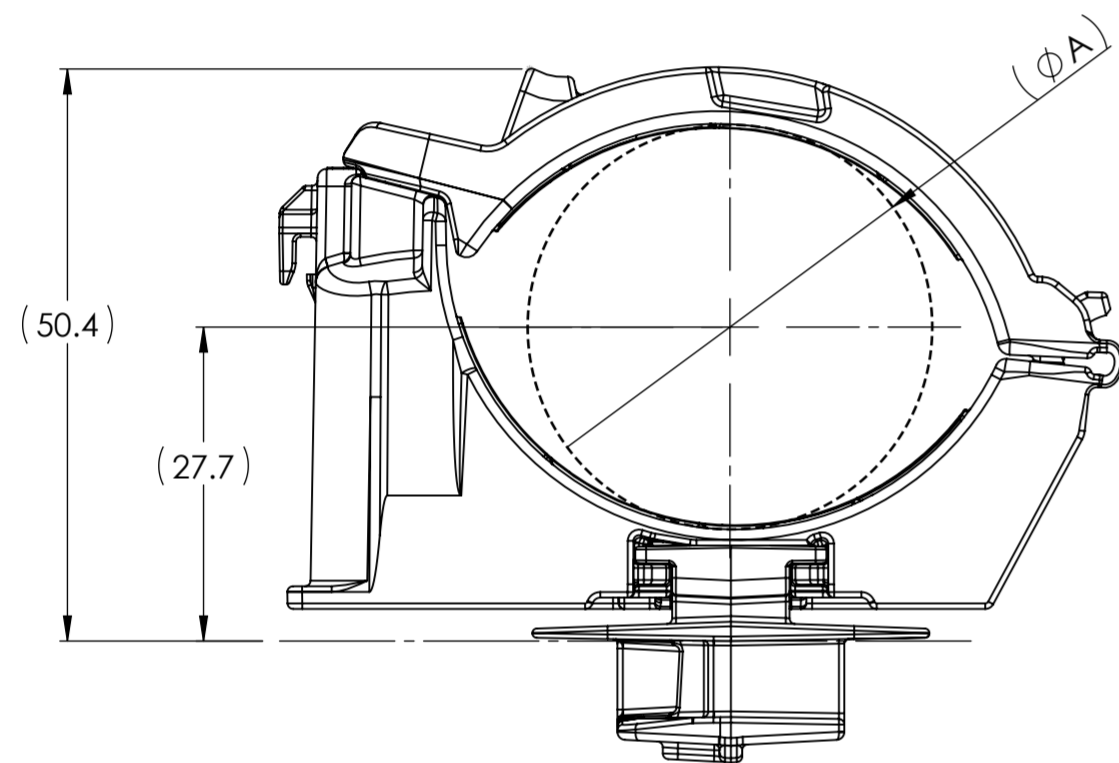

Minimum Bundle Diameter

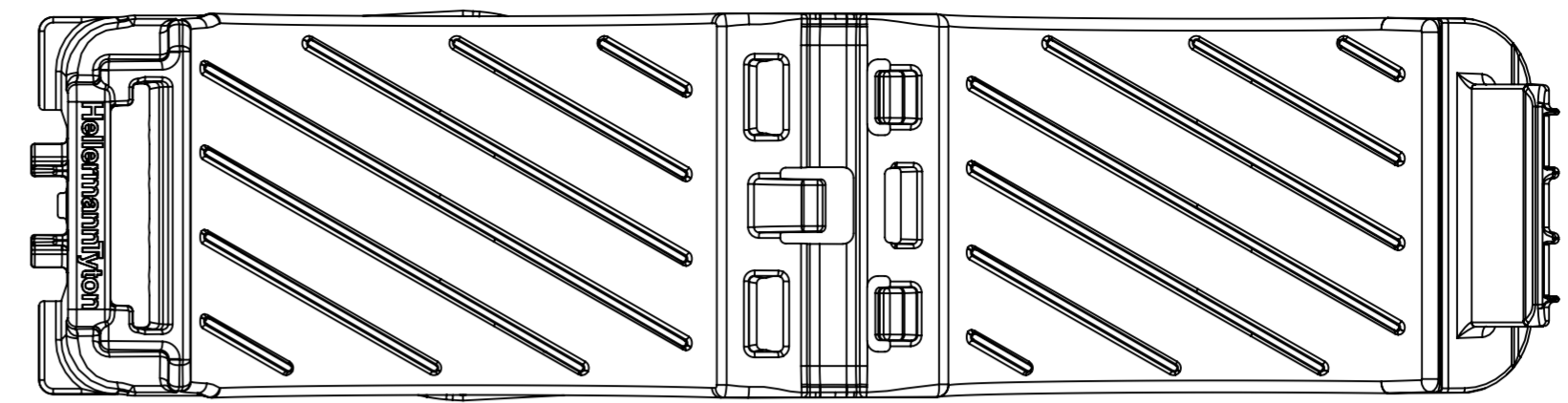
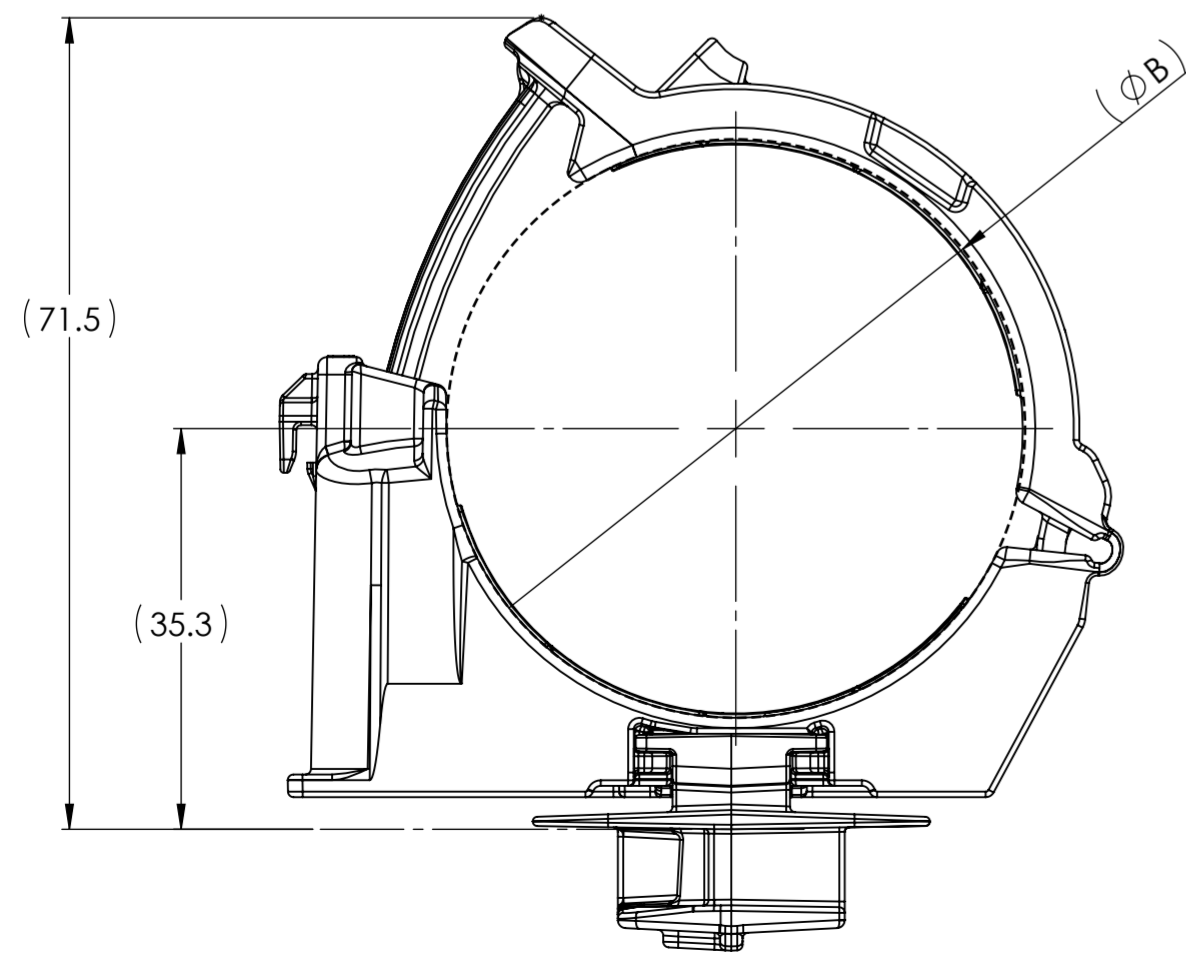
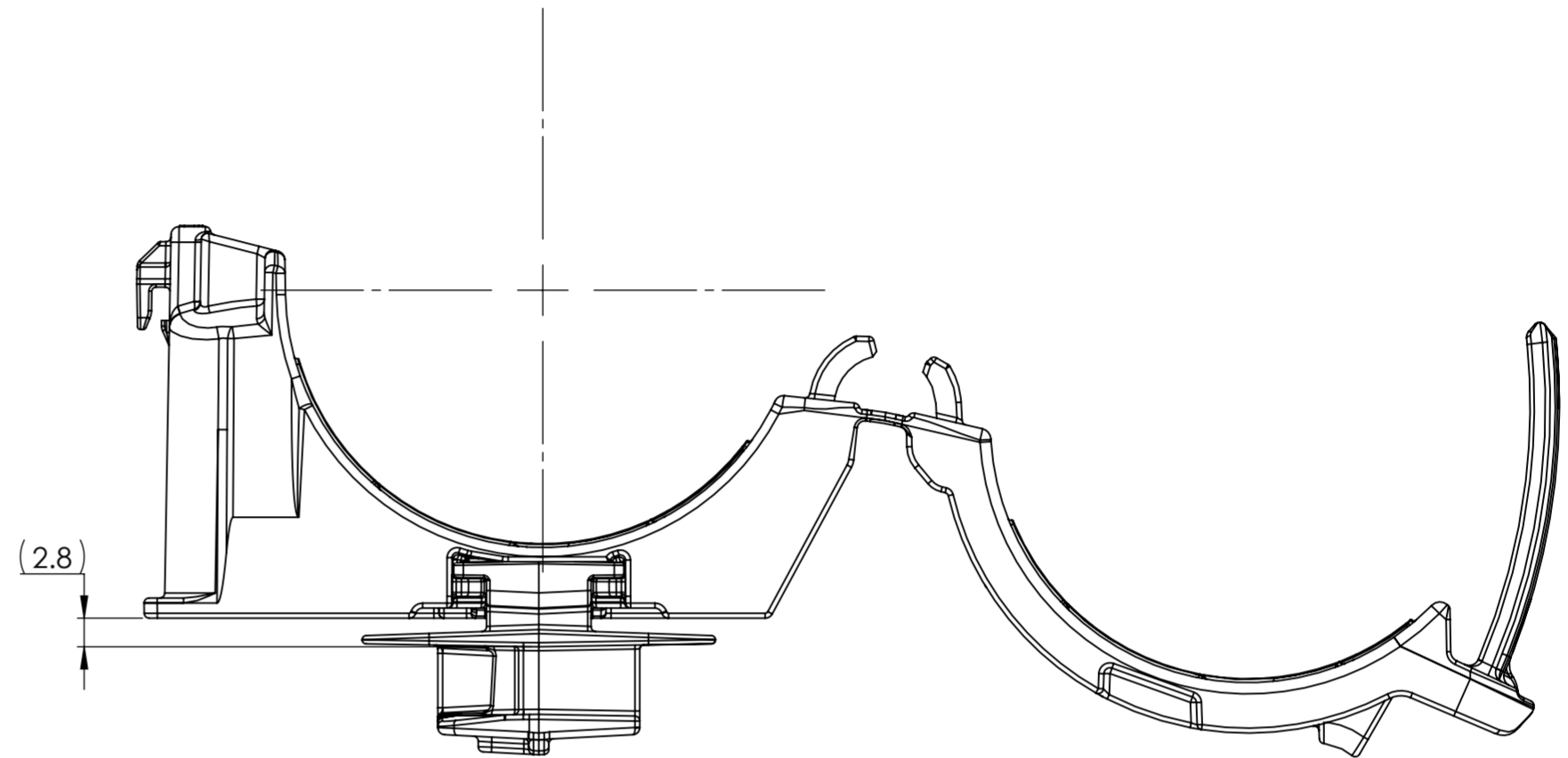
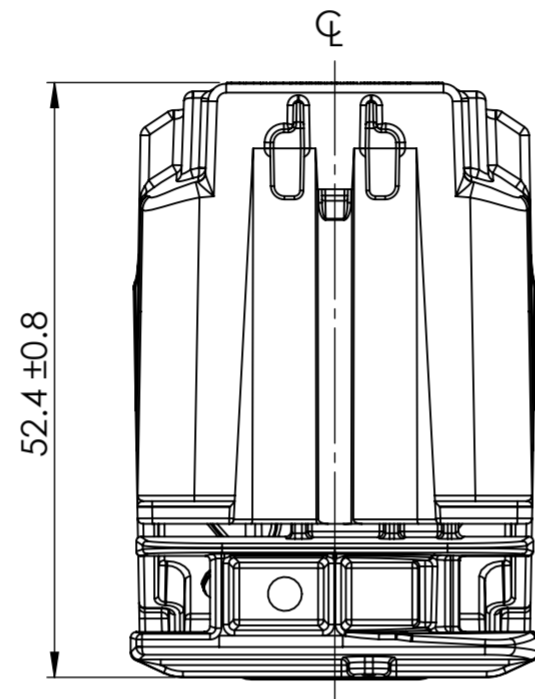

Maximum Bundle Diameter

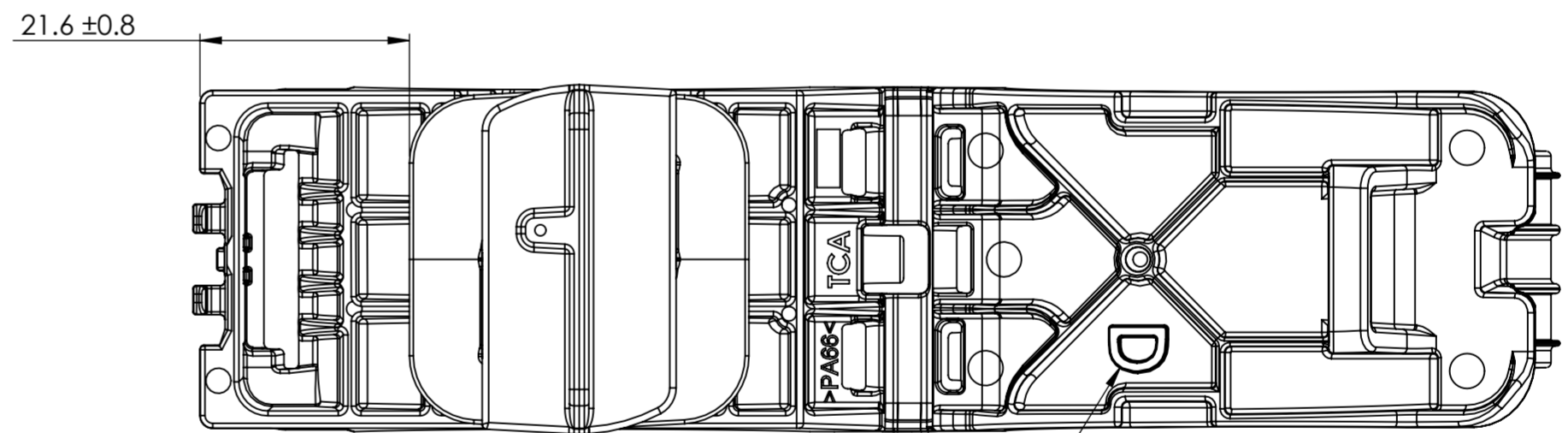

Size Identifier

Initial Mold Validation:
Dry as molded with $\leq 0.5\%$ moisture content:

ITS-0003 Ratchet Clamp Solid Mandrel Test:
Exceeded 311 newtons (70 lbf) min at a nominal
bundle diameter of 15.88

Global Part Description	Bundle Types	(A) Minimum Diameter	(B) Maximum Diameter	IRCD CLAMP			IRCSTRUT Connector Clip		
				Drawing	Material	Color	Drawing	Material	Color
IRCDSTRUT-PA66HIRHSUV-BK	Soft Hard	36.0 35.2	51.0 49.9	16-1642-004-CSU	PA66HIRHSUV	BLACK	19-2104-001-CSU	PA66HIRHSUV	Black

Revision level			Revision Record		
Drawing	State	Part	ECN#	Date	By
00.0	Design Release	-	015881		
Changed	Date				
Toll	2020/05/01				
Approved	Date				
Lewinski	2020/05/01				

The copyright of this drawing is reserved by HellermannTyton.

Drawn: Toll, Date: 2020/04/30
Approved: Lewinski, Date: 2020/04/30
Units: mm
HellermannTyton
www.HellermannTyton.com

Title: Inline Ratchet P-Clamp D-Size with 1-5/8" Strut Attachment
Scale: 3:2
Global Project Number: 19-2107
Drawing-No: 19-2107-104-CSU
Format: A2
Sheet: 1/1