

May.1.2023 Copyright 2023 HIROSE ELECTRIC CO., LTD. All Rights Reserved.  
In case of consideration for using Automotive equipment / device which demand high reliability, kindly contact our sales window correspondents.

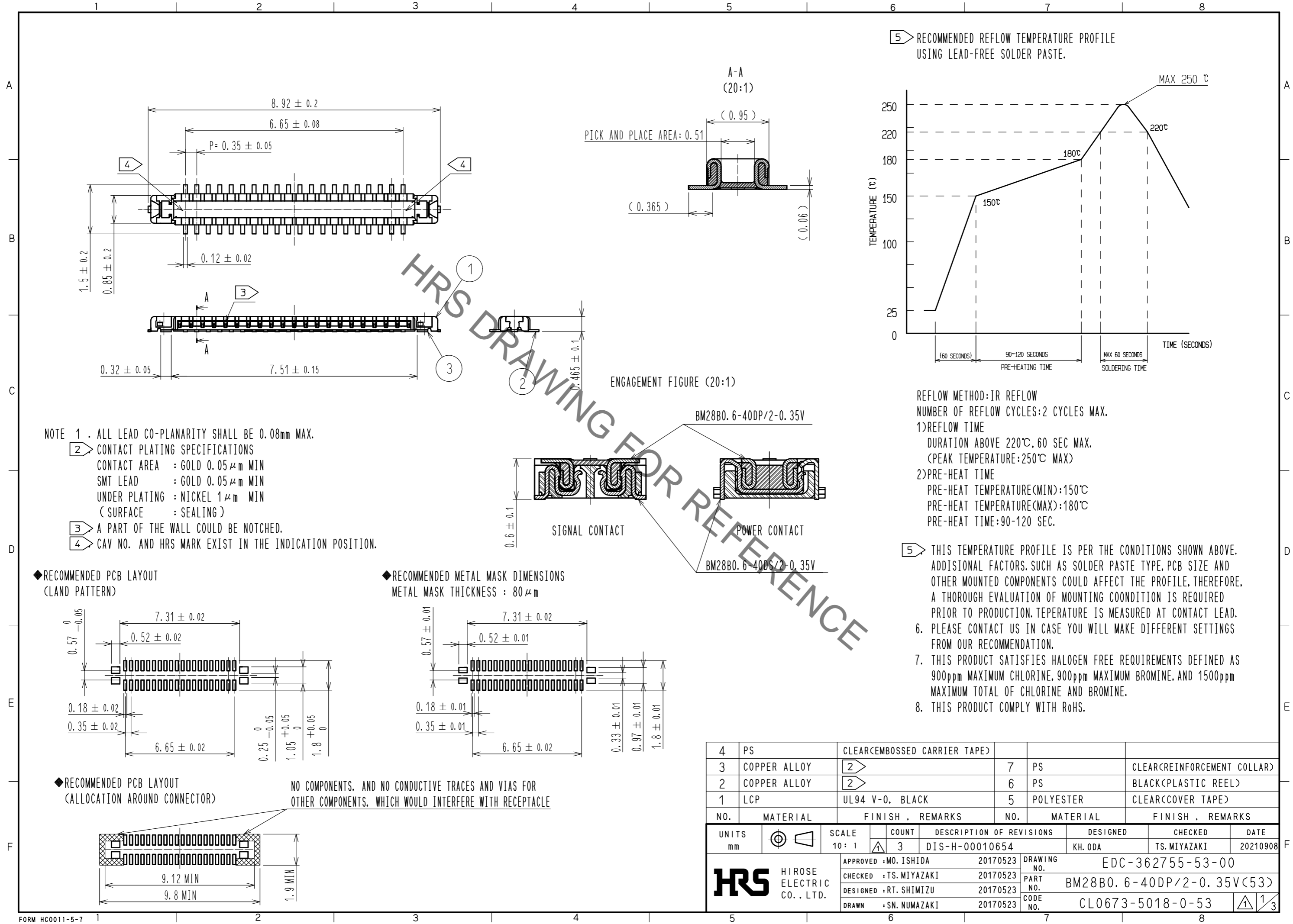

- NOTE 1 . ALL LEAD CO-PLANARITY SHALL BE 0.08mm MAX.  
 2 CONTACT PLATING SPECIFICATIONS  
 CONTACT AREA : GOLD 0.05 μm MIN  
 SMT LEAD : GOLD 0.05 μm MIN  
 UNDER PLATING : NICKEL 1 μm MIN  
 ( SURFACE : SEALING )  
 3 A PART OF THE WALL COULD BE NOTCHED.  
 4 CAV NO. AND HRS MARK EXIST IN THE INDICATION POSITION.

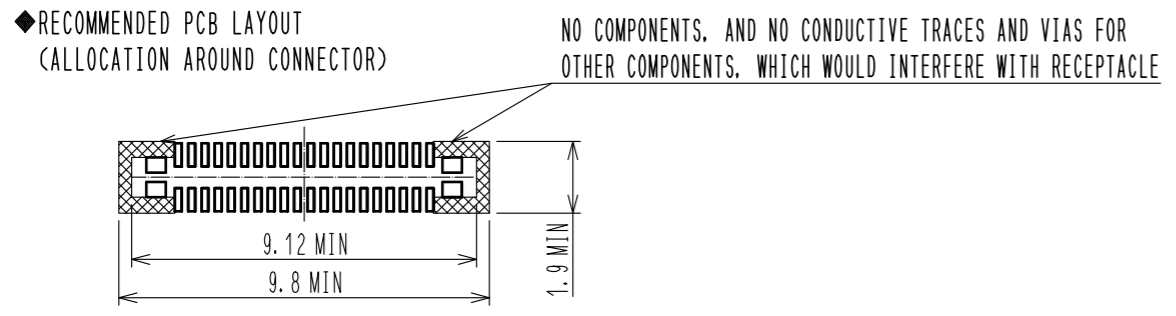
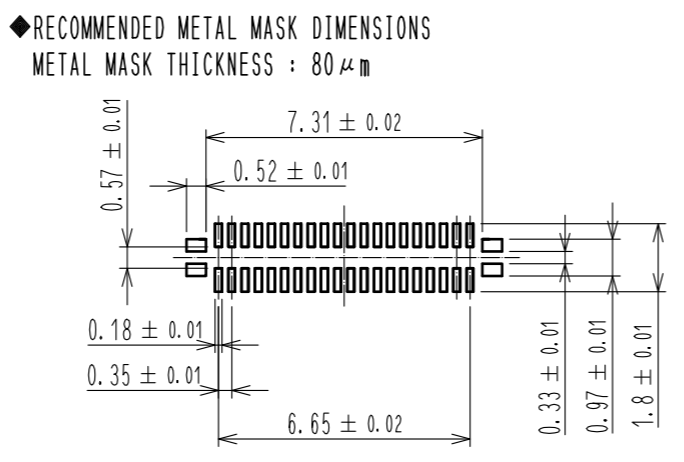
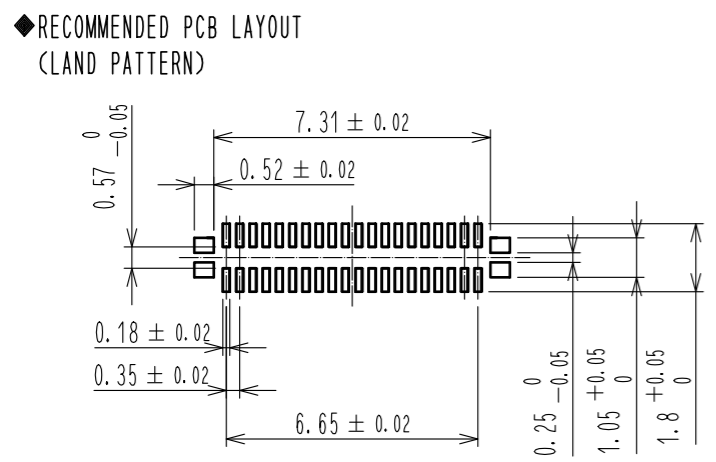

4	PS	CLEAR(EMBOSSED CARRIER TAPE)			
3	COPPER ALLOY	2	7	PS	CLEAR(REINFORCEMENT COLLAR)
2	COPPER ALLOY	2	6	PS	BLACK(PLASTIC REEL)
1	LCP	UL94 V-0, BLACK	5	POLYESTER	CLEAR(COVER TAPE)
NO.	MATERIAL	FINISH . REMARKS	NO.	MATERIAL	FINISH . REMARKS
UNITS	mm	SCALE	10:1	COUNT	3
		DESCRIPTION OF REVISIONS	DESIGNED	CHECKED	DATE
		DIS-H-00010654	KH. ODA	TS. MIYAZAKI	20210908
APPROVED : MO. ISHIDA		20170523	DRAWING NO. EDC-362755-53-00		
CHECKED : TS. MIYAZAKI		20170523	PART NO. BM28B0. 6-40DP/2-0. 35V(53)		
DESIGNED : RT. SHIMIZU		20170523	CODE NO. CL0673-5018-0-53		
DRAWN : SN. NUMAZAKI		20170523			

May.1.2023 Copyright 2023 HIROSE ELECTRIC CO., LTD. All Rights Reserved.  
 In case of consideration for using Automotive equipment / device which demand high reliability, kindly contact our sales window correspondents.

# EMBOSED CARRIER TAPE PACKAGING (5:1)

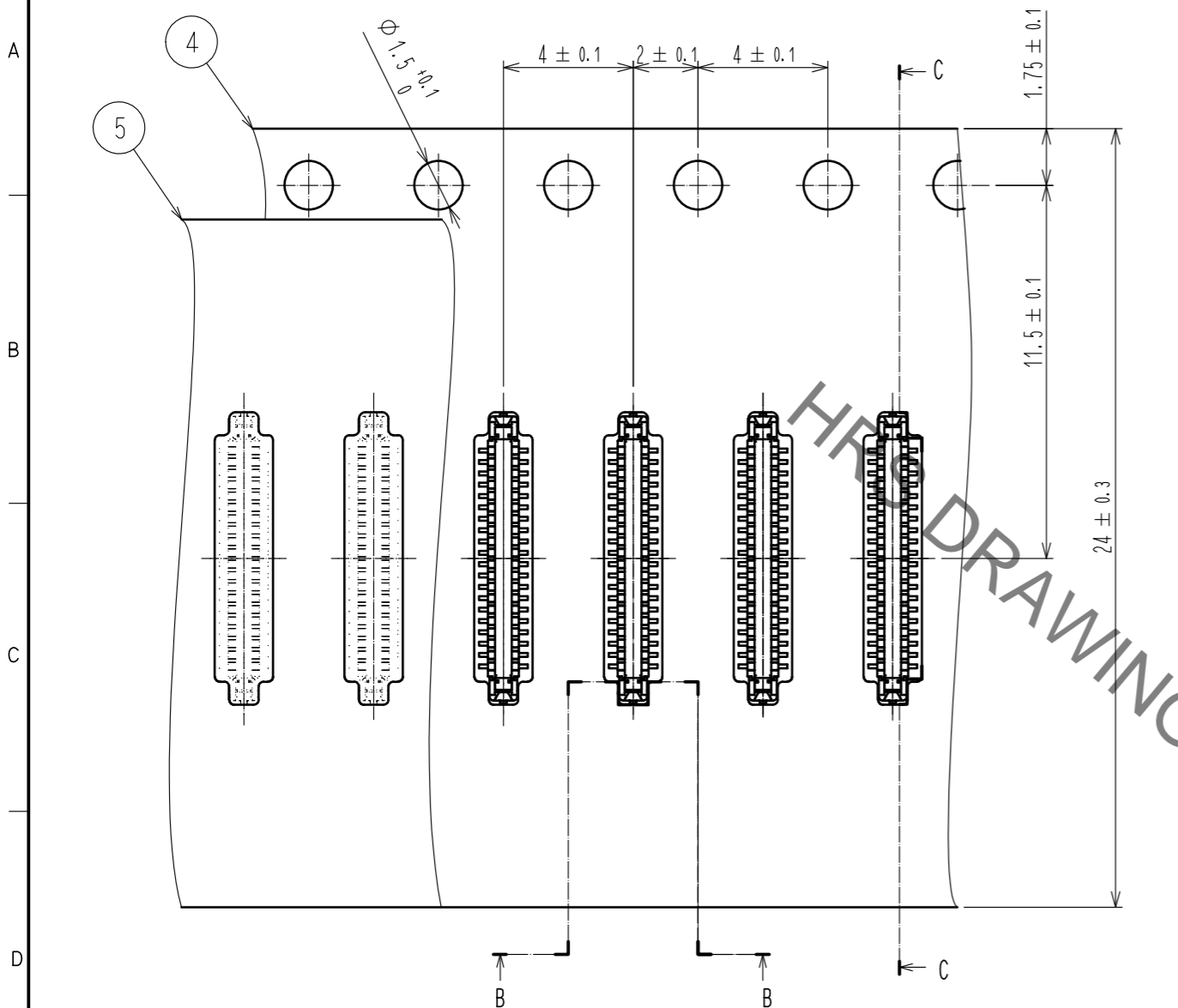

## C-C (5:1)

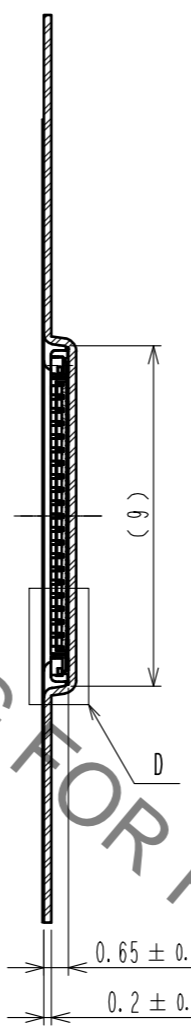

## STYLE AND DIMENSION OF REEL (FREE)

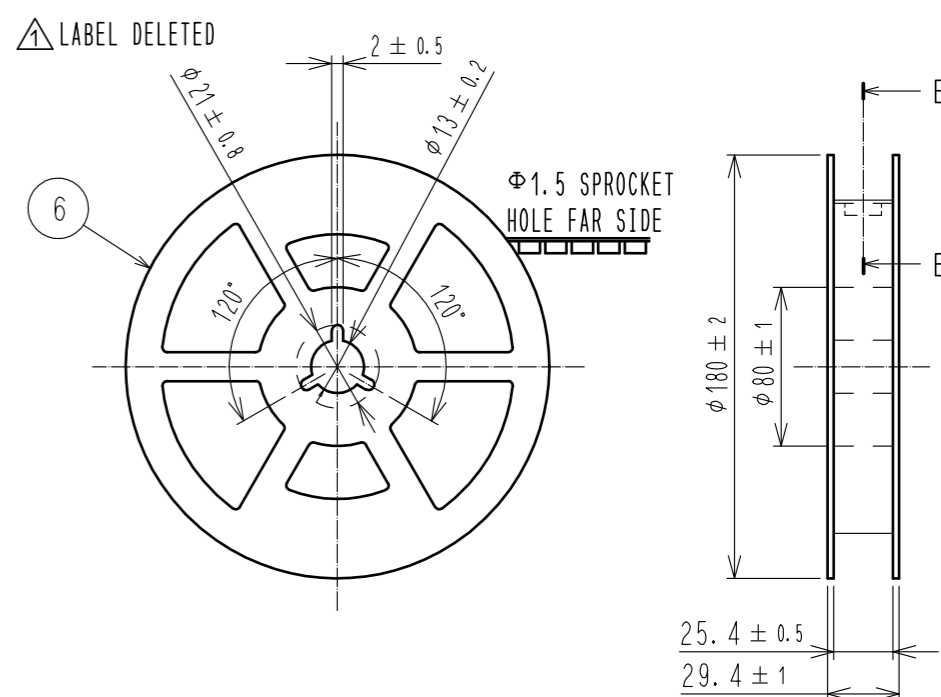

## E-E (FREE)

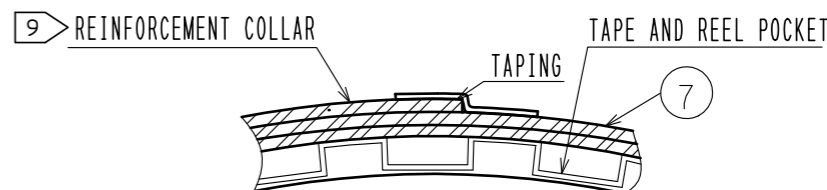

## B-B (5:1)

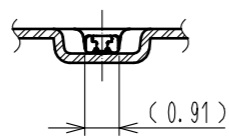

DIRECTION OF UNREELING

## D (10:1)

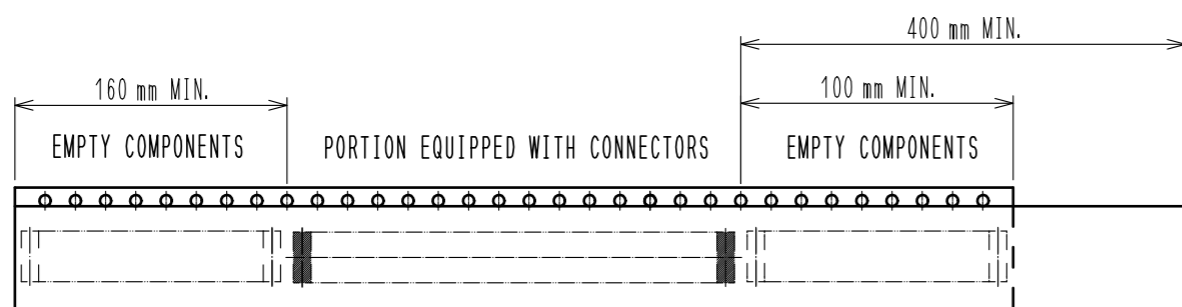
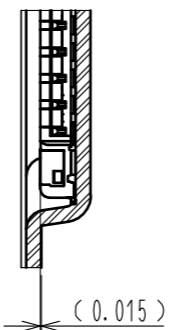

12 TAPING(FREE)

- 9 . AFTER PACKAGING. ROLL 2 METERS OF THE REINFORCEMENT COLLAR TO OUTER CIRCUMFERENCE OF TAPE AND REEL POCKET. AND TAPE DOWN AT THE END THE COLLAR.
- 10 . PER REEL 1,000 CONNECTORS.
- 11 . THE DIMENSIONS IN PARENTHESES ARE FOR REFERENCE.
- 12 . REFER TO JIS C 0806, IEC 60286-3(PACKAGING OF COMPONENTS FOR AUTOMATIC HANDLING)

<b>HRS</b>	DRAWING NO.	EDC-362755-53-00
	PART NO.	BM28B0. 6-40DP/2-0. 35V(53)
	CODE NO.	CL0673-5018-0-53
		2/3

May.1.2023 Copyright 2023 HIROSE ELECTRIC CO., LTD. All Rights Reserved.  
In case of consideration for using Automotive equipment / device which demand high reliability, kindly contact our sales window correspondents.

△13. PLEASE REFER TO THE PRODUCT GUIDELINE ETAD-H1016 FOR DETAIL OF CONNECTOR HANDLING.

THE POSITION BETWEEN THE CONNECTOR AND PAD

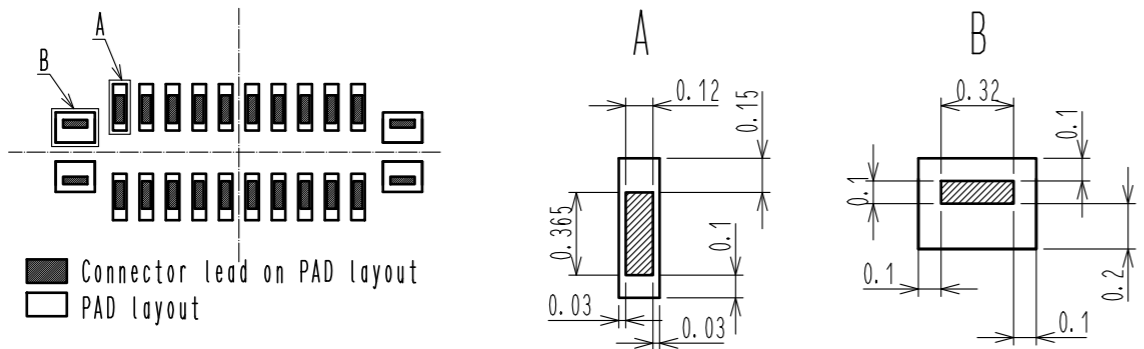

MATING METHOD

PLEASE MATE THE CONNECTOR BY HAND.

MATING PROCEDURE

- (1) FIND THE ALIGNMENT AREA TO THE CONNECTOR IN THE APPROPRIATE MATING POSITION.  
 THIS CONNECTOR HAS AN ALIGNMENT CHAMBER(GUIDANCE RIBS) ON RECEPTACLE SIDE AND 'R' ON PLUG SIDE.  
 SO THAT THE CONNECTOR WILL BE SELF-ALIGNED.  
 WHEN THE CONNECTOR COMES TO THE APPROPRIATE POSITION, THE CONNECTOR GOES INTO THE ALIGNED POSITION.  
 WHEN ALIGNED, IT CAN BE FELT BY HAND.

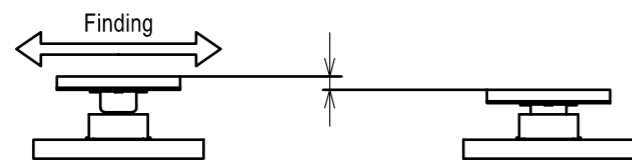
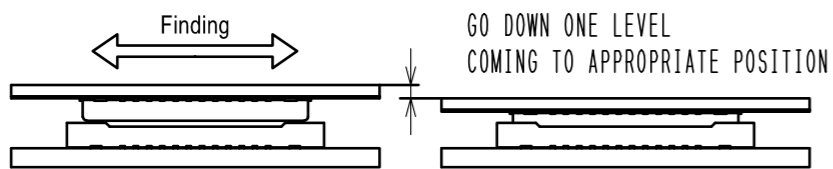

- (2) WHEN GUIDING, THE CONNECTORS ARE ALIGNED PARALLEL TO EACH OTHER, WITH LONGITUDINAL AND LATERAL MOVEMENTS RESTRICTED. MATE THEM PROPERLY BY APPLYING FORCE IN THIS CONDITION.

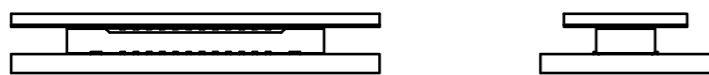

- (3) MAKE SURE THE CONNECTORS ARE MATED CORRECTLY. IF ONE SIDE IS FLOATING OR THE CONNECTORS ARE MATED IN ONE DIRECTION, UN-MATE THEM ONCE, AND THEN MATE THEM AGAIN, FOLLOWING THE PROCEDURES ABOVE FROM THE BEGINNING.

UN-MATING METHOD

PLEASE UN-MATE THE CONNECTOR BY HAND

- (1) UN-MATE THE CONNECTORS PARALLEL TO EACH OTHER. HOWEVER, IF THE CONNECTORS HAVE HIGH PIN COUNTS OR THINNER FPC AND STIFFENER, IT BECOMES MORE DIFFICULT TO DO SO.

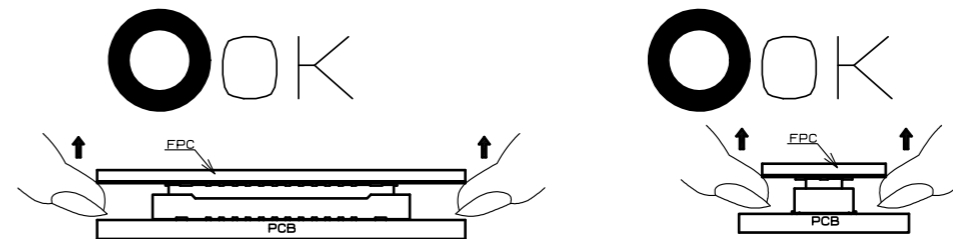

- (2) IF THE CONNECTOR CANNOT BE UN-MATED PARALLEL IT CAN BE REMOVED DIAGONALLY FROM THE PITCH DIRECTION. BE CAREFUL TO DO SO SINCE THIS ACTION APPLIES STRESS ON THE CONTACT.

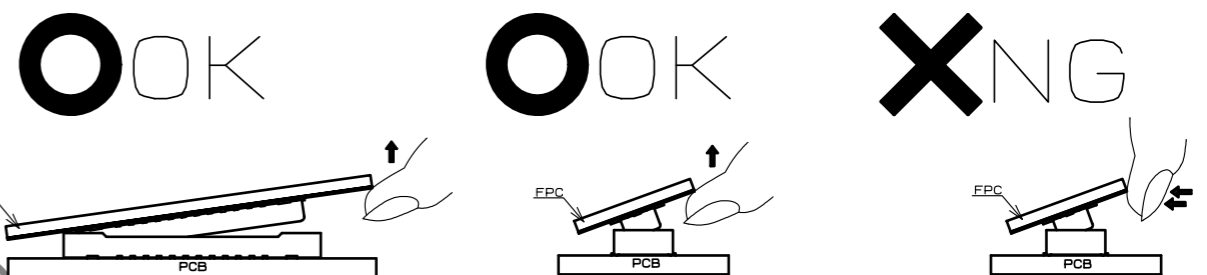

- (3) IF THE FPC IS NOT RIGID, THE CONNECTOR CAN BE BROKEN. PLEASE CHECK THE ACTION OF THE FPC TO BE USED REPEATEDLY AT THE TIME OF TRIAL PRODUCTION. BE CAREFUL TO UN-MATE THEM FROM THE PITCH DIRECTION, PULLING IT FROM THE CORNER CAN ALSO RISK TO PUTTING STRESS ON CONTACTS.

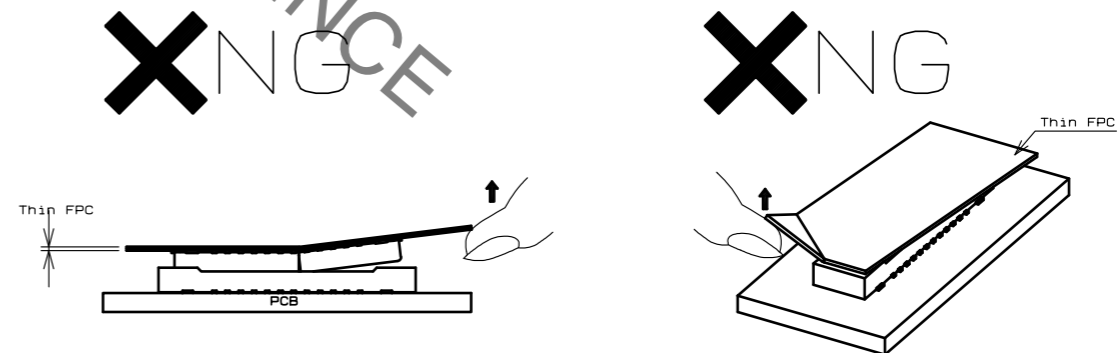

<b>HRS</b>	DRAWING NO.	EDC-362755-53-00	
	PART NO.	BM28B0. 6-40DP/2-0. 35V(53)	
	CODE NO.	CL0673-5018-0-53	△ 3/3