

DO NOT SCALE FROM THIS PRINT

SEAF-XX-XX-X-XX-X-RA-XX-TR

No. OF POSITIONS  
-20,-30,-40,-50  
(PER ROW)

LEAD STYLE  
-01

PLATING SPECIFICATION  
-S: SELECTIVE GOLD,  
30μ GOLD, MATTE TIN ON TAILS  
(USE SUB-IM-C-242-XX-S-X)  
-L: LIGHT SELECTIVE GOLD,  
10μ GOLD, MATTE TIN ON TAILS  
(USE SUB-IM-C-242-XX-L-X)

No. OF ROWS  
-04,-06,\*-08,\*-10  
(\* = SEE NOTE 8)

PACKAGING  
-TR: TAPE & REEL  
(STANDARD PACKAGING)  
(SEE NOTE 4 & 7)

OPTIONS  
-GP: GUIDE POST HOLE  
-LP: LATCH POST  
(USE WITH SEAC ONLY)  
(-06 ROW, ALL POS AND  
-08 ROW, 40 POS ONLY)  
(NOT AVAILABLE WITH -GP OPTION)  
-K: PAD

RIGHT ANGLE  
-RA

SOLDER COMPOSITION & STYLE

-1: 63% TIN / 37% LEAD CHARGE TAIL  
(USE SUB-IM-C-242-XX-XX-1)  
-2: 95.5% TIN / 3.8 SILVER / 0.7% COPPER  
LEAD FREE CHARGE TAIL  
(USE SUB-IM-C-242-XX-XX-2)

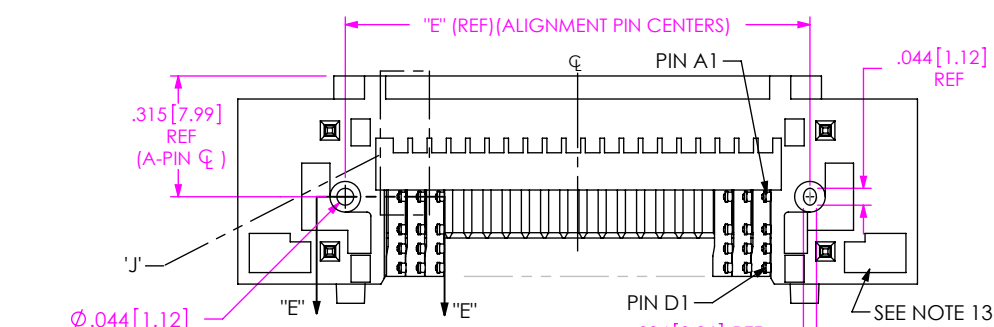
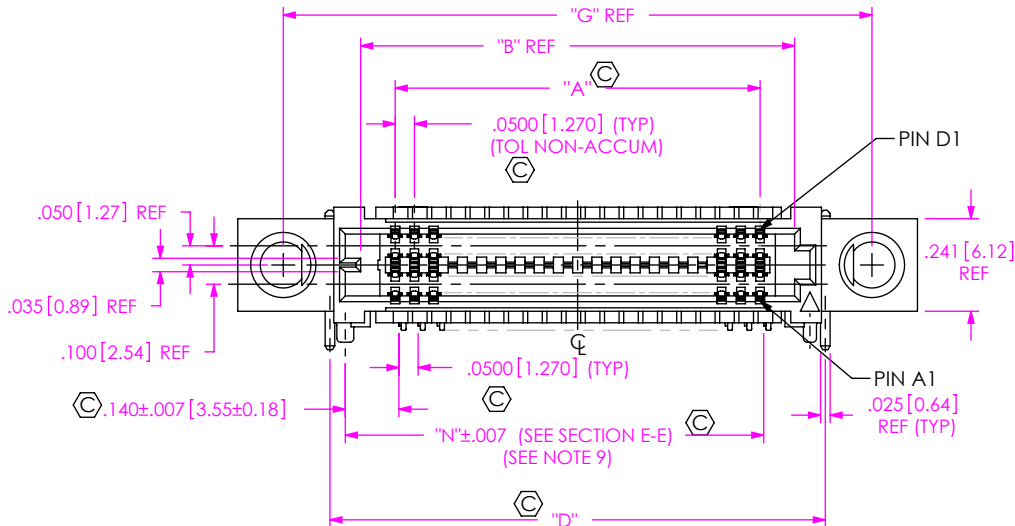
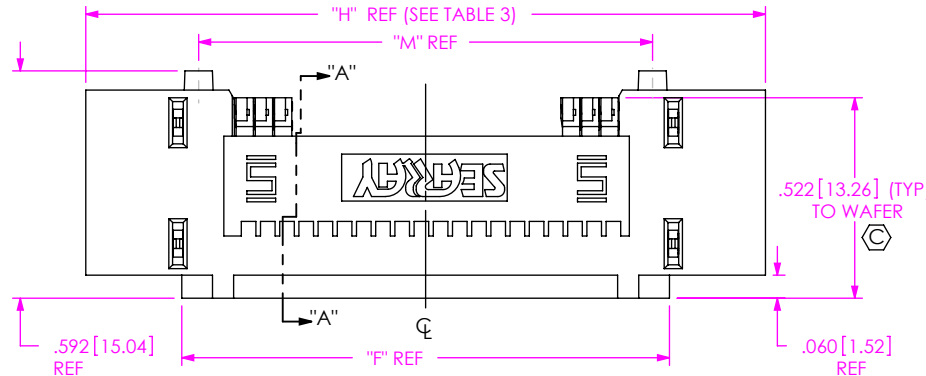


FIG 1 (SEAF-20-01-X-04-X-RA-GP)  
(SOME DETAIL OMITTED FOR CLARITY)

TABLE 3

STYLE	No. OF POS PER ROW	"G"	"H"	"J"	
STANDARD WITH -GP OPTION	-20	1.533 [38.94]	1.770 [44.96]	N/A	
	-30	2.033 [51.64]	2.270 [57.66]		
	-40	2.533 [64.34]	2.770 [70.36]		
	-50	3.033 [77.04]	3.270 [83.06]		
WITHOUT -GP OPTION	-20	N/A	1.370 [34.80]		
	-30		1.870 [47.50]		
	-40		2.370 [60.20]		
	-50		2.870 [72.90]		
WITH-LP OPTION	-20	1.533 [38.94]	1.900 [48.26]		1.790 [45.47]
	-30	2.033 [51.64]	2.400 [60.96]		2.290 [58.17]
	-40	2.533 [64.34]	2.900 [73.66]	2.790 [70.10]	
	-50	3.033 [77.04]	3.400 [86.36]	3.290 [83.57]	

TABLE 2

No. OF ROWS	"BODY CALLOUT"	"SOCKET WAFER"	"WELD TAB"	"C"
-04	SEAF-XX-01-RA-04-XX	SUB-IM-C-242-01-04-X-X	WT-28-01-T	0.315 [8.00]
-06	SEAF-XX-01-RA-06-XX	SUB-IM-C-242-01-06-X-X	WT-28-02-T	0.415 [10.54]
*-08	SEAF-XX-01-RA-08-XX	SUB-IM-C-242-01-08-X-X	WT-83-01-T	0.415 [10.54]
*-10	SEAF-XX-01-RA-10-XX	SUB-IM-C-242-01-10-X-X	WT-83-02-T	0.415 [10.54]

TABLE 1

No. OF POS. PER ROW	"A"	"B"	"D"	"E"	"F"	"N"
-20	0.950 [24.13]	1.130 [28.70]	1.290 [32.77]	1.210 [30.73]	1.270 [32.26]	1.090 [27.69]
-30	1.450 [36.83]	1.630 [41.40]	1.790 [45.47]	1.710 [43.43]	1.770 [44.96]	1.590 [40.39]
-40	1.950 [49.53]	2.130 [54.10]	2.290 [58.17]	2.210 [56.13]	2.270 [57.66]	2.090 [53.09]
-50	2.450 [62.23]	2.630 [66.80]	2.790 [70.87]	2.710 [68.83]	2.770 [70.36]	2.590 [65.79]

TABLE 4

No. OF ROWS	"M"				"BACK STRAP"
	20 POS	30 POS	40 POS	50 POS	
-04	1.182 [30.02]	1.682 [42.72]	2.182 [55.42]	2.682 [68.12]	N/A
-06,*-08 & *-10	N/A	N/A	N/A	N/A	SEAX-RA-BS-XX-01

NOTES:

1. REPRESENTS A CRITICAL DIMENSION.
2. MINIMUM PUSH-OUT FORCE: .50 LBS[2.2N].
3. INSPECT DIMENSION AT FIRST POSITION WAFER LOCATION ONLY, FIRST AND LAST PIN.
4. ONLY FULL REEL QUANTITIES ARE SHIPPED ON A REEL WITH LEADER AND TRAILER.
5. NOTE DELETED
6. NOTE DELETED
7. ATTACH LABEL "SEAX-0001" TO EACH TAPE & REEL PACKAGE.
8. ON -08 & -10 ROW ASSEMBLIES, SEE FIG 10, SHEET 5 FOR CAT FIXTURE VIEW.
9. CHECK DIMENSION ON FIRST AND LAST ROW OF TAILS.
10. A 20-30°C TEMPERATURE DIFFERENCE MAY EXIST BETWEEN THIS HIGH-DENSITY COMPONENT AND THE BOARD SURFACE DURING REFLOW. SAMTEC RECOMMENDS A THERMAL STUDY BE PERFORMED TO UNDERSTAND THE TEMPERATURE GRADIENTS YOU MAY EXPERIENCE.
11. SOME RELAXATION/WARPING OF THE BACK STRAP IS ACCEPTABLE AFTER PROCESSING.
12. SEE SHEET 5 FOR PROCESSING INFORMATION.
13. VOID PATTERN MAY VARY BY ROW AND END OPTION.

UNLESS OTHERWISE SPECIFIED, DIMENSIONS ARE IN INCHES.  
TOLERANCES ARE:  
DECIMALS ANGLES  
.XX: ±.01 [.3]  
.XXX: ±.005 [.13]  
.XXXX: ±.0020 [.051]

PROPRIETARY NOTE  
THIS DOCUMENT CONTAINS CONFIDENTIAL AND PROPRIETARY INFORMATION AND ALL DESIGN, MANUFACTURING, REPRODUCTION, USE, PATENT RIGHTS AND SALES RIGHTS ARE EXPRESSLY RESERVED BY SAMTEC, INC. THIS DOCUMENT SHALL NOT BE DISCLOSED, IN WHOLE OR PART, TO ANY UNAUTHORIZED PERSON OR ENTITY NOR REPRODUCED, TRANSFERRED OR INCORPORATED IN ANY OTHER PROJECT IN ANY MANNER WITHOUT THE EXPRESS WRITTEN CONSENT OF SAMTEC, INC.



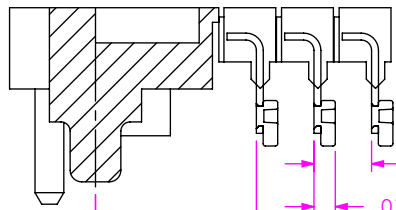
520 PARK EAST BLVD. NEW ALBANY, IN 47150  
PHONE: 812-944-6733 FAX: 812-948-5047  
e-Mail info@SAMTEC.com code 55322

MATERIAL: DO NOT SCALE DRAWING SHEET SCALE: 2:1  
INSULATOR: LCP COLOR: BLACK UL 94 V-0  
CONTACT: COPPER ALLOY .006 THICK

DESCRIPTION:  
SEAF-RA ASSEMBLY

DWG. NO.  
SEAF-XX-XX-X-XX-X-RA-XX-TR

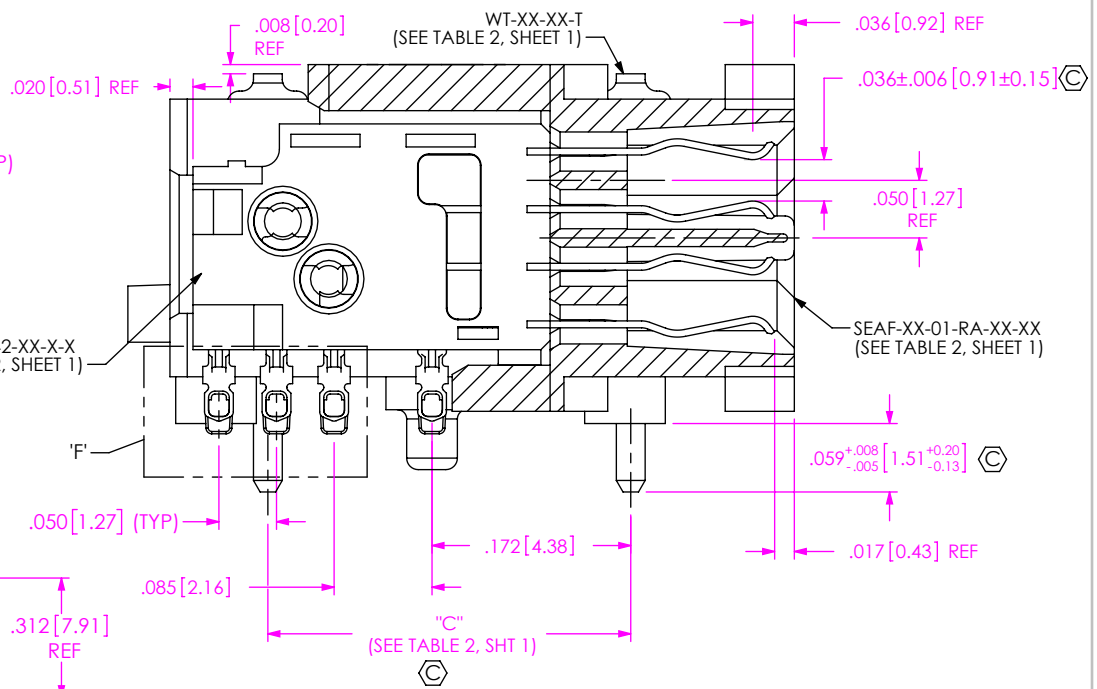
BY: C. PIERCE 12/15/2007 SHEET 1 OF 5



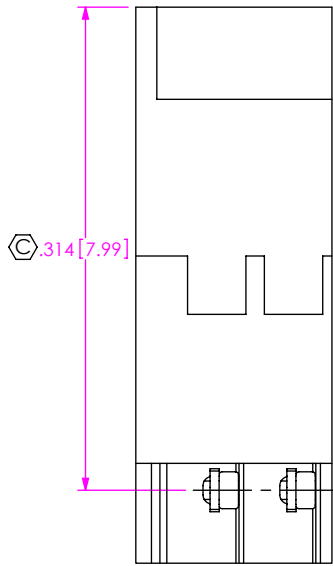
.050 [1.27] (TYP)  
 .0185±.0030 [0.470±0.076] (TYP)  
 .140 [3.55] REF  
 "N" REF (SEE TABLE 1, SHT 1)

SECTION "E"-"E"  
 SCALE 6:1

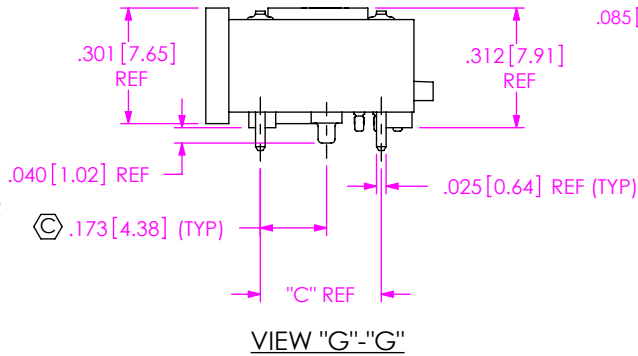
SUB-IM-C-242-XX-X-X  
 (SEE TABLE 2, SHEET 1)



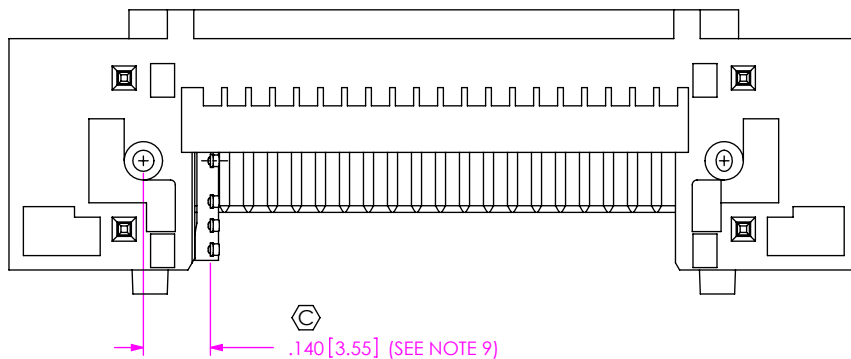
SECTION "A"-"A"  
 SCALE 6:1



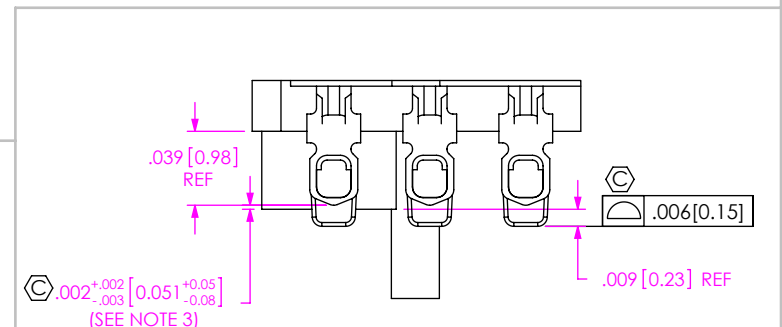
DETAIL 'J'  
 SCALE 8:1



VIEW "G"-"G"



IN-PROCESS VIEW  
 (SEAF-20-01-X-04-X-RA-GP SHOWN)  
 (FILL FIRST WAFER TO DIMENSIONS SHOWN)



DETAIL 'F'  
 SCALE 10:1

**PROPRIETARY NOTE**  
 THIS DOCUMENT CONTAINS CONFIDENTIAL AND PROPRIETARY INFORMATION AND ALL DESIGN, MANUFACTURING, REPRODUCTION, USE, PATENT RIGHTS AND SALES RIGHTS ARE EXPRESSLY RESERVED BY SAMTEC, INC. THIS DOCUMENT SHALL NOT BE DISCLOSED, IN WHOLE OR PART, TO ANY UNAUTHORIZED PERSON OR ENTITY NOR REPRODUCED, TRANSFERRED OR INCORPORATED IN ANY OTHER PROJECT IN ANY MANNER WITHOUT THE EXPRESS WRITTEN CONSENT OF SAMTEC, INC.

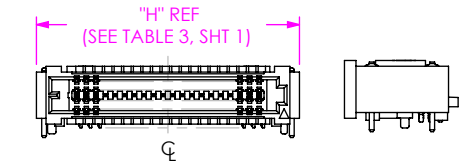
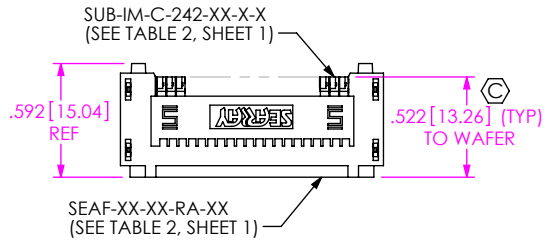


520 PARK EAST BLVD, NEW ALBANY, IN 47150  
 PHONE: 812-944-6733 FAX: 812-948-5047  
 e-Mail info@SAMTEC.com code 55322

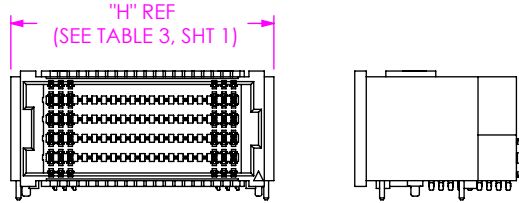
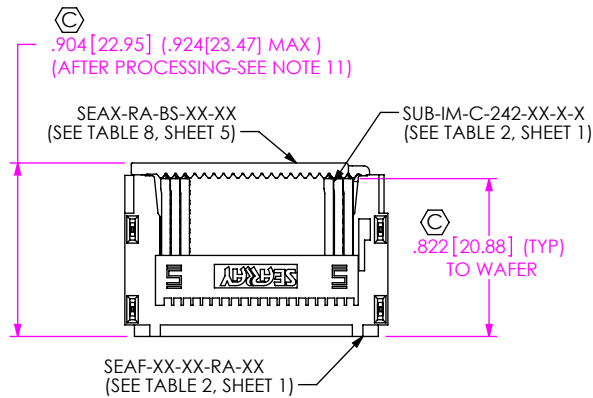
DO NOT SCALE DRAWING  
 SHEET SCALE: 2:1

DESCRIPTION:  
**SEAF-RA ASSEMBLY**  
 DWG. NO.  
**SEAF-XX-XX-X-XX-X-RA-XX-TR**

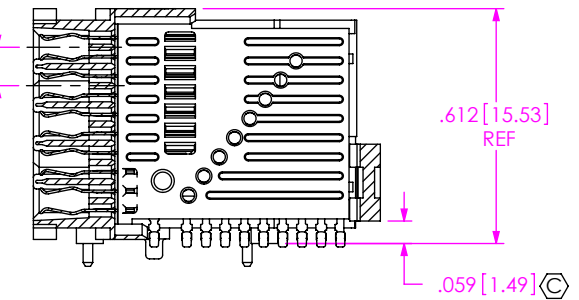
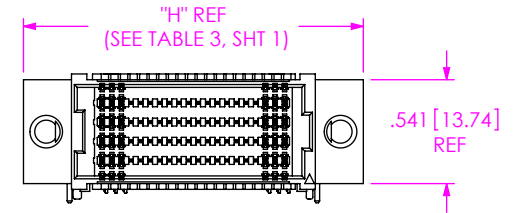
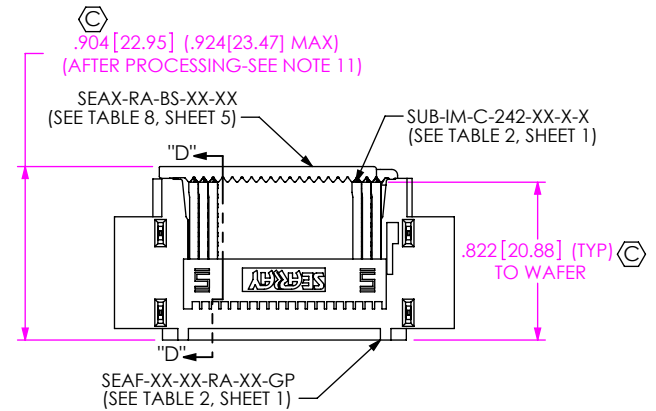
BY: C. PIERCE 12/15/2007 SHEET 2 OF 5



**FIG 2**  
(SEAF-20-01-X-04-X-RA SHOWN)  
(SAME AS FIG 1 EXCEPT AS NOTED)  
(SOME DETAIL REMOVED FOR CLARITY)

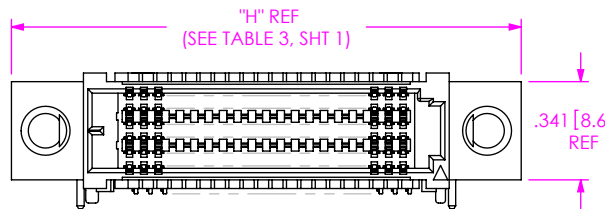
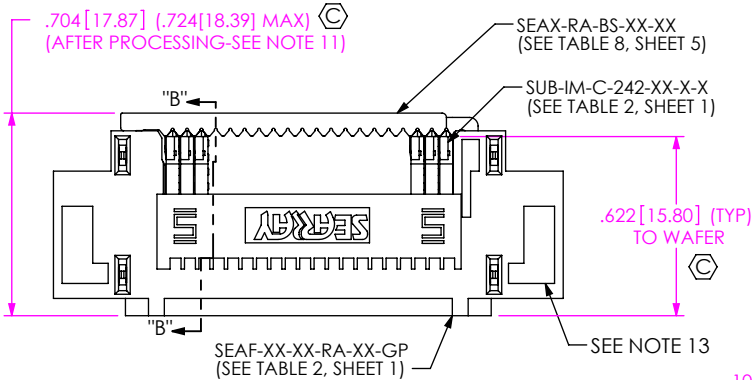


**FIG 9**  
(SEAF-20-01-X-10-X-RA SHOWN)  
(SAME AS FIG 4 EXCEPT AS NOTED)  
(SOME DETAIL REMOVED FOR CLARITY)

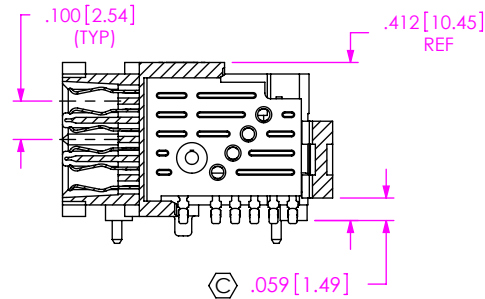


**SECTION "D"-"D"**  
**SCALE 2 : 1**

**FIG 4**  
(SEAF-20-01-X-10-X-RA-GP)  
(SAME AS FIG 1 EXCEPT AS NOTED)  
(SOME DETAIL REMOVED FOR CLARITY)



**FIG 3**  
(SEAF-20-01-X-06-X-RA-GP)  
(SAME AS FIG 1 EXCEPT AS NOTED)  
(SOME DETAIL REMOVED FOR CLARITY)



**SECTION "B"-"B"**  
**SCALE 2 : 1**

**PROPRIETARY NOTE**  
THIS DOCUMENT CONTAINS CONFIDENTIAL AND PROPRIETARY INFORMATION AND ALL DESIGN, MANUFACTURING, REPRODUCTION, USE, PATENT RIGHTS AND SALES RIGHTS ARE EXPRESSLY RESERVED BY SAMTEC, INC. THIS DOCUMENT SHALL NOT BE DISCLOSED, IN WHOLE OR PART, TO ANY UNAUTHORIZED PERSON OR ENTITY NOR REPRODUCED, TRANSFERRED OR INCORPORATED IN ANY OTHER PROJECT IN ANY MANNER WITHOUT THE EXPRESS WRITTEN CONSENT OF SAMTEC, INC.



520 PARK EAST BLVD. NEW ALBANY, IN 47150  
PHONE: 812-944-6733 FAX: 812-948-5047  
e-Mail info@SAMTEC.com code 55322

DO NOT SCALE DRAWING

SHEET SCALE: 1:1

DESCRIPTION:

SEAF-RA ASSEMBLY

DWG. NO.

SEAF-XX-XX-X-XX-X-RA-XX-TR

BY: C. PIERCE 12/15/2007 SHEET 3 OF 5

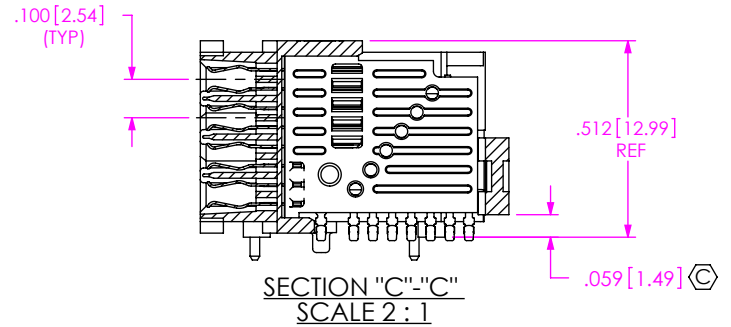
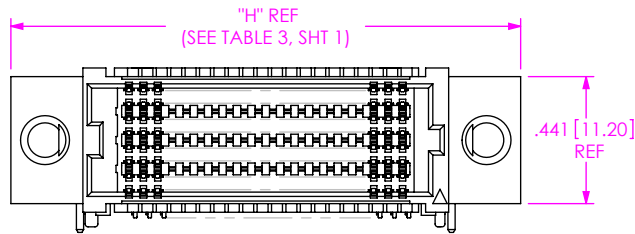
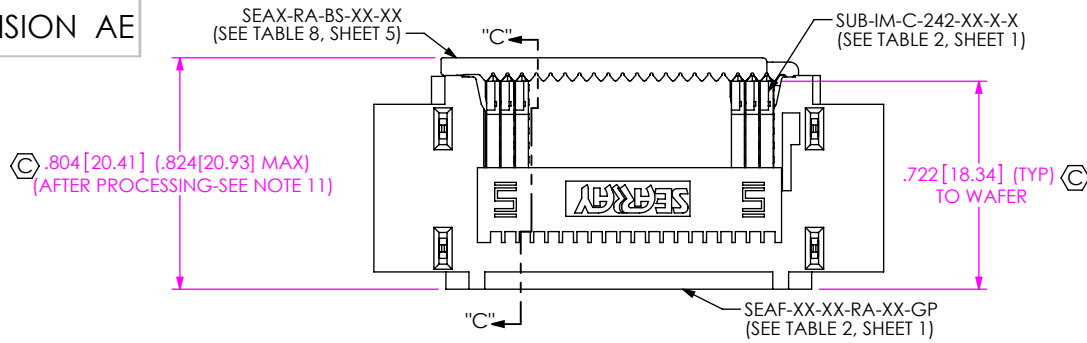


FIG 5  
(SEAF-20-01-X-08-X-RA-GP)  
(SAME AS FIG 1 EXCEPT AS NOTED)  
(SOME DETAIL REMOVED FOR CLARITY)

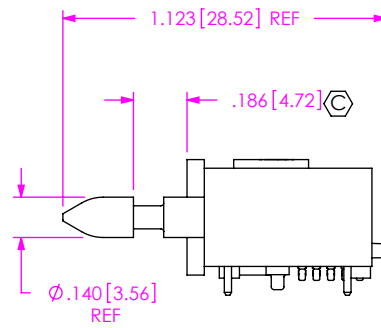
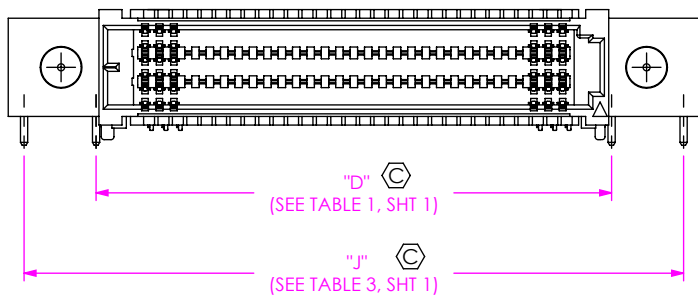
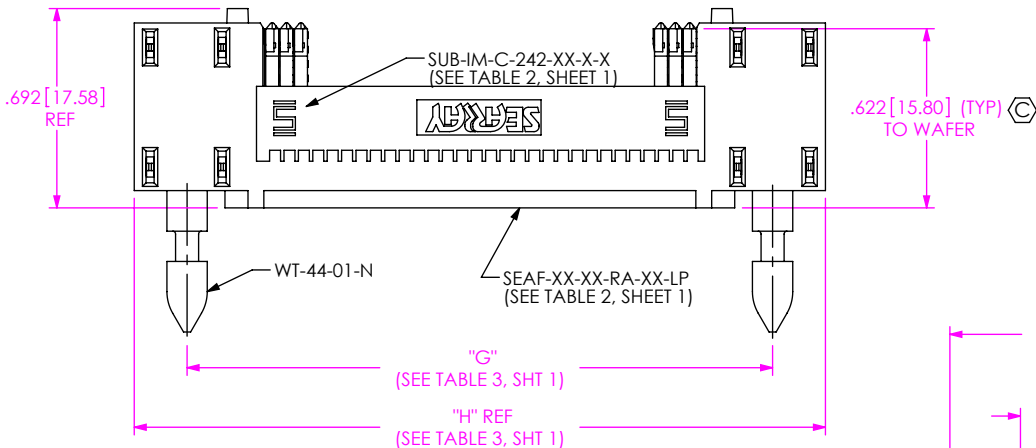


FIG 6  
(SEAF-30-01-X-06-X-RA-LP)  
(SOME DETAIL OMITTED FOR CLARITY)  
(SAME AS FIG 3 EXCEPT AS SHOWN)

<p><b>PROPRIETARY NOTE</b></p> <p>THIS DOCUMENT CONTAINS CONFIDENTIAL AND PROPRIETARY INFORMATION AND ALL DESIGN, MANUFACTURING, REPRODUCTION, USE, PATENT RIGHTS AND SALES RIGHTS ARE EXPRESSLY RESERVED BY SAMTEC, INC. THIS DOCUMENT SHALL NOT BE DISCLOSED, IN WHOLE OR PART, TO ANY UNAUTHORIZED PERSON OR ENTITY NOR REPRODUCED, TRANSFERRED OR INCORPORATED IN ANY OTHER PROJECT IN ANY MANNER WITHOUT THE EXPRESS WRITTEN CONSENT OF SAMTEC, INC.</p>		
	<p>520 PARK EAST BLVD, NEW ALBANY, IN 47150 PHONE: 812-944-6733 FAX: 812-948-5047 e-Mail info@SAMTEC.com code 55322</p>	
DO NOT SCALE DRAWING	DESCRIPTION: SEAF-RA ASSEMBLY	
SHEET SCALE: 1:1	DWG. NO. SEAF-XX-XX-X-XX-X-RA-XX-TR	
	BY: C. PIERCE 12/15/2007	SHEET 4 OF 5

ROWS	TABLE 5																
	"L"		"P" $\phi$		"K" NO -GP OPTION				"K" WITH -GP OPTION				"K" WITH -LP OPTION				"Q"
	20 POS	30 POS	40 POS	50 POS	20 POS	30 POS	40 POS	50 POS	20 POS	30 POS	40 POS	50 POS	20 POS	30 POS	40 POS	50 POS	
-04	.276 [7.01]	.295 [7.49]	.538 [13.65]	.788 [20.00]	1.038 [26.35]	1.288 [32.70]	.738 [18.73]	.988 [25.08]	1.238 [31.43]	1.488 [37.78]	N/A	N/A	N/A	N/A	N/A	N/A	.124 [3.15]
-06	.376 [9.55]	.295 [7.49]	.538 [13.65]	.788 [20.00]	1.040 [26.40]	1.288 [32.70]	.738 [18.73]	.988 [25.08]	1.238 [31.43]	1.488 [37.78]	.803 [20.38]	1.053 [26.73]	1.303 [33.08]	1.553 [39.43]	N/A	N/A	.124 [3.15]
-08	.483 [12.27]	.649 [16.48]	.361 [9.16]	.611 [15.51]	.861 [21.86]	1.111 [28.21]	.561 [14.24]	.811 [20.59]	1.061 [26.94]	1.311 [33.29]	.626 [15.89]	.876 [22.24]	1.126 [28.59]	1.376 [34.94]	N/A	N/A	.030 [0.76]
-10	.583 [14.81]	.649 [16.48]	.361 [9.16]	.611 [15.51]	.861 [21.86]	1.111 [28.21]	.561 [14.24]	.811 [20.59]	1.061 [26.94]	1.311 [33.29]	N/A	N/A	N/A	N/A	N/A	N/A	.030 [0.76]

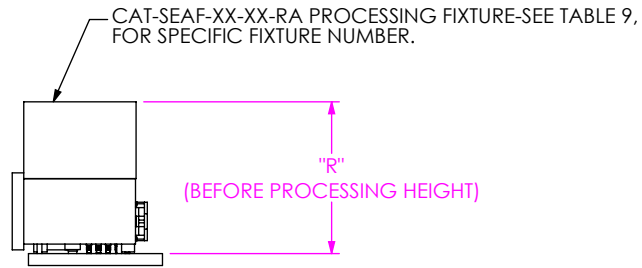
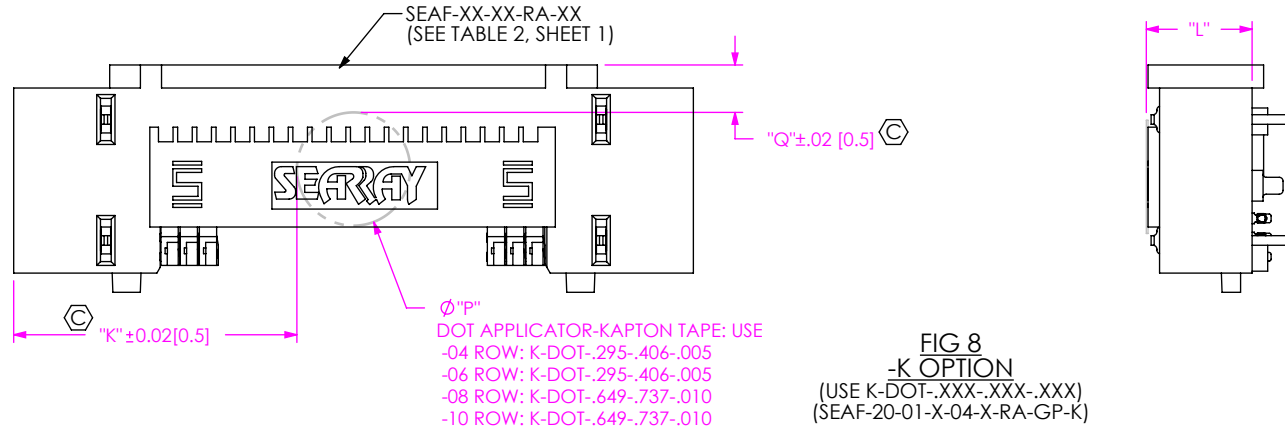


TABLE 7	
ROW	"R"
-08	.892 [22.66]
-10	.992 [25.20]

NOTE:  
 FIG 10, DIMENSION "R" INDICATES CONNECTOR/FIXTURE HEIGHT ON PCB. TO GUARANTEE ENOUGH REFLOW OVEN WORKING SPACE, DIMENSION "R", PCB THICKNESS, AND THE HEIGHT OF THE COMPONENTS ON THE OPPOSITE SIDE OF THE BOARD NEED TO BE CONSIDERED.

FIG 10  
 SEAF-RA PROCESSING FIXTURE  
 (USE CAT-SEAF-XX-XX-RA FIXTURE)

TABLE 9		
SEARAY™ FIXTURE TOOLS		
PART NUMBER	POSITIONS	ROW
CAT-SEAF-20-01-RA	20	-08 AND -10
CAT-SEAF-30-01-RA	30	-08 AND -10
CAT-SEAF-40-01-RA	40	-08 AND -10
CAT-SEAF-50-01-RA	50	-08 AND -10

TABLE 8	
No. OF POSITIONS	"BACKSTRAP"
-20	SEAX-RA-BS-20-01
-30	SEAX-RA-BS-30-01
-40	SEAX-RA-BS-40-01
-50	SEAX-RA-BS-50-01

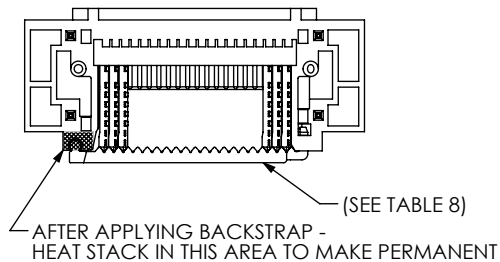


FIG 11  
 HEAT STAKING BACKSTRAP

**PROPRIETARY NOTE**  
 THIS DOCUMENT CONTAINS CONFIDENTIAL AND PROPRIETARY INFORMATION AND ALL DESIGN, MANUFACTURING, REPRODUCTION, USE, PATENT RIGHTS AND SALES RIGHTS ARE EXPRESSLY RESERVED BY SAMTEC, INC. THIS DOCUMENT SHALL NOT BE DISCLOSED, IN WHOLE OR PART, TO ANY UNAUTHORIZED PERSON OR ENTITY NOR REPRODUCED, TRANSFERRED OR INCORPORATED IN ANY OTHER PROJECT IN ANY MANNER WITHOUT THE EXPRESS WRITTEN CONSENT OF SAMTEC, INC.

**samtec**  
 520 PARK EAST BLVD, NEW ALBANY, IN 47150  
 PHONE: 812-944-6733 FAX: 812-948-5047  
 e-Mail info@SAMTEC.com code 55322

DO NOT SCALE DRAWING  
 SHEET SCALE: 2:1

DESCRIPTION:  
 SEAF-RA ASSEMBLY

DWG. NO.  
**SEAF-XX-XX-X-XX-X-RA-XX-TR**

BY: C. PIERCE 12/15/2007 SHEET 5 OF 5