

M5Core2

U:K010

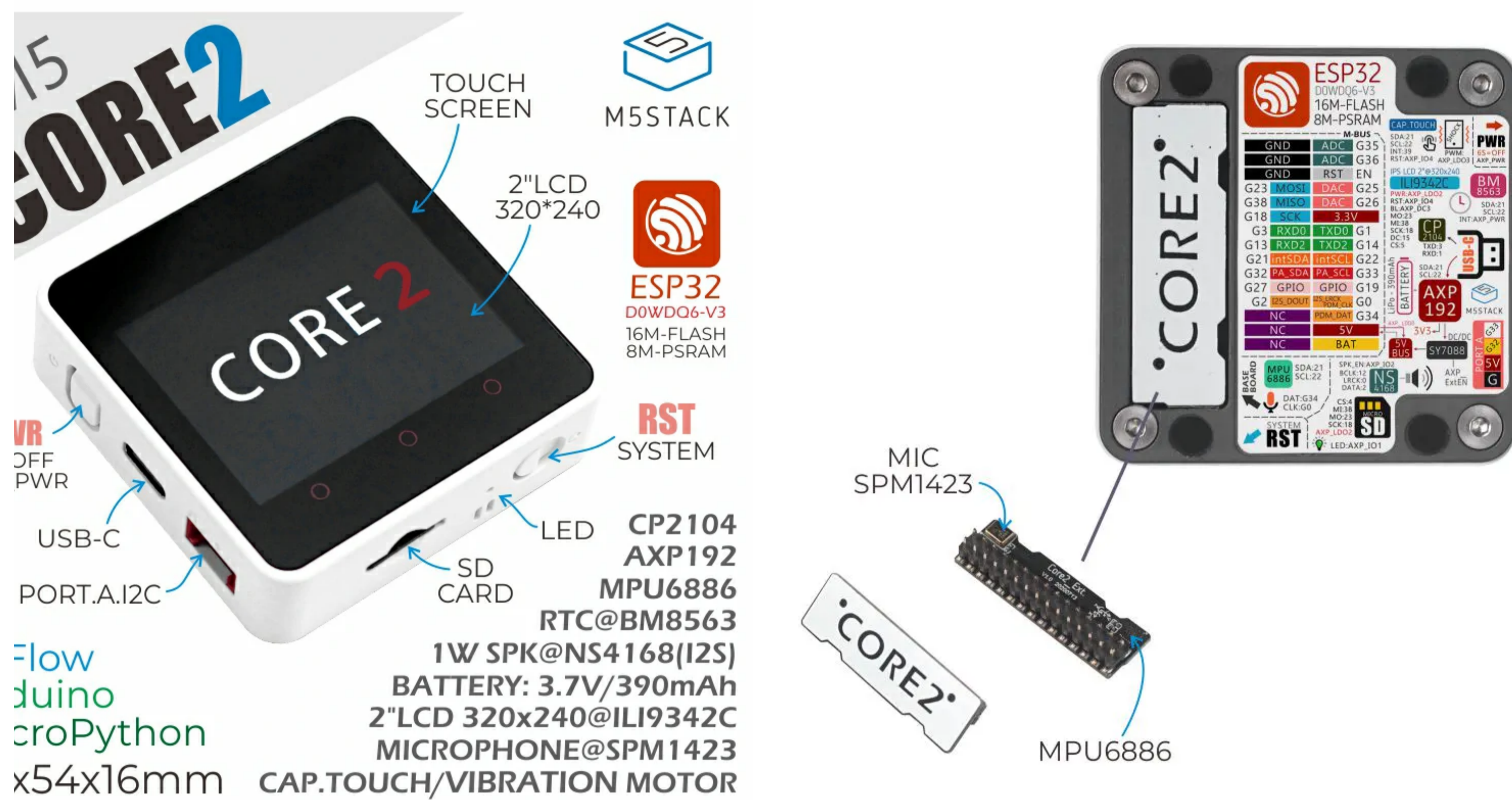

Tutorial & Quick-Start

Use the development platform you want to use, view the corresponding tutorial & quick-start.

Flow [Arduino](#)

Description

M5Core2 is the second generation core device in the M5Stack development kit series, which further enhances the functions of the original generation of M5Stack.

M5Core2 MCU is an ESP32 model D0WDQ6-V3 and has dual core Xtensa® 32-bit 240Mhz LX6 processors that can be controlled separately. WiFi and Bluetooth are supported as standard and it includes an on board 16MB Flash and 8MB PSRAM, USB TYPE-C interface for charging, downloading of programs and data communication, a 2.0-inch integrated capacitive touch screen, and a built-in vibration motor.

M5Core2 also features a built-in RTC module which can provide accurate timing. The power supply is managed by an AXP192 power management chip, which can effectively control the power consumption of the base and a built-in green LED power indicator helps to notify the user of battery level. The battery capacity has been upgraded to 390mAh, which can power the core for much longer than the previous model.

M5Core2 retains the TF-card(microSD) slot and speakers. However, in order to ensure higher quality sound output, the I2S digital audio interface peripheral chip is used to effectively prevent signal distortion. There are independent power and reset buttons on the left side and bottom of the base.

Three icons on the front of the screen are capacitive buttons which are programmable. There is a small expansion board on the back of the base with a MPU6886 sensor and microphone. The development platform and programming language supported by M5Stack Core2: Arduino, [UIFlow](#) (using Blockly, JavaScript, Python language) No matter what level of your development and programming skills, M5Stack will help You gradually turn your ideas into reality.

Power Management

Operations:

Power on: One click the power button on the left

Power off: Long press the left power button for 6 seconds

Reset: Click the RST button on the bottom side

Core2 is adopting AXP192 as power chip. Please initialize the 'mbus' mode per the powering method, as below:

```
//mbus_mode_t:  
//kMbusModeOutput: Powered by USB or battery  
//kMbusModeInput: Powered by external 5V or DC jack  
  
M5.begin(bool LCDEnable = true, bool SDEnable = true, bool SerialEnable = true, bool I2CEnable = false, mbus_mode_t mode =  
MbusModeOutput);
```

USB drive

Before using, please go to [download page](#) to download the USB driver that matches your operating system, and install it.

Note: **Core2** currently has two CP2104/CH9102F A USB chip version, users can install the drivers (**CH34x** and **CP210x**) that are compatible with two ICs at the same time to ensure that the device drivers work normally.

Extensions

To stack M5Core2 with M5 modules, you need to remove/eliminate the battery bottom of Core2; If you wish to keep I2S Mic, IMU and Battery functions, a **M5GO Bottom2** is required.**The CP2104 chip interface is reserved on the PCB of CORE2 to interface with the lithium battery.

Product Features

SP32-based, built-in Bluetooth,WiFi

6M Flash,8M PSRAM

Built-in speaker, power indicator, vibration motor, RTC, I2S amplifier, capacitive touch screen, power button, reset button

TF card slot (16G Maximum size)

Built-in lithium battery, equipped with power management chip

Independent small board built-in 6-axis IMU, PDM microphone

I2C-Bus Socket & Pins

Program Platform: [UIFlow](#), [MicroPython](#), [Arduino](#)

Package include

1 x M5Stack Core2

1 x Type-C USB(20cm)

Applications

Internet of things terminal controller

STEM education product

DIY creation

Smart home equipment

Specification

Resources	Parameter
ESP32-D0WDQ6-V3	240MHz dual core, 600 DMIPS, 520KB SRAM, Wi-Fi, dual mode Bluetooth
Flash	16MB
PSRAM	8MB
Input Voltage	5V @ 500mA
Interface	TypeC x 1, GROVE(I2C+I/O+UART) x 1
IPS LCD Screen	2.0"@320*240 ILI9342C
Touch Screen	FT6336U
Speaker amplifier	NS4168
LED	Green power indicator light
Button	Power button, RST button, Virtual screen button*3
Vibration reminder	Vibration motor
MIC	SPM1423
I2S Power Amplifier	NS4168
6-axis IMU	MPU6886
RTC	BM8563
PMU	AXP192
USB Chip	CP2104/CH9102F (two chip versions, there is no difference in function and use)
DC-DC Boost	SY7088
TF card slot	16G Max
Lithium Battery	390mAh @ 3.7V
Antenna	2.4G 3D antenna
Operating temperature	0°C to 60°C
Net Weight	52g
Gross Weight	70g
Product Size	54 x 54 x 16mm
Package Size	75 x 60 x 20mm

Resources	Parameter
Case Material	Plastic (PC)

asyLoader

EasyLoader is a concise and fast program writer, which has a built-in case program related to the product. It can be burned to the main control by simple steps to perform a series of function verification.

[Download Windows Version Easyloader](#)

[Download MacOS Version Easyloader](#)

Description:

This case will perform hardware running tests for speakers, wifi, buttons, accelerometer, TF-card(microSD), screen, etc.

inMap

& TF card

: 320x240 TF card Maximum size 16GB

SP32 Chip	GPIO38	GPIO23	GPIO18	GPIO5	GPIO15		
XP192 Chip						AXP_IO4	AXP_DC3
ILI9342C	MISO	MOSI	SCK	CS	DC	RST	BL

ESP32 Chip	GPIO38	GPIO23	GPIO18	GPIO4
TF Card	MISO	MOSI	SCK	CS

TOUCH

ESP32 chip	GPIO21	GPIO22	GPIO39
AXP192			
FT6336U	SDA	SCL	INT

& NS4168(Speaker)

ESP32 Chip	GPIO12	GPIO0	GPIO2	AXP_IO2	GPIO34
NS4168	BCLK	LRCK	DATA	SPK_EN	
Mic		CLK			DATA

Power Indicator Light

AXP192	AXP_IO1	AXP_LDO3

Green LED	Vcc	AXP_PWR
Vibration motor		Vcc

ESP32 Chip	GPIO21	GPIO22
AXP192		AXP_PWR
BM8563	SDA	SCL
		INT

(3-axis gyroscope & 3-axis accelerometer)

ESP32 Chip	GPIO21	GPIO22
MPU6886	SDA	SCL

to serial chip

ESP32 Chip	GPIO1	GPIO3
CP2104	RXD	TXD

nal I2C connection

ESP32 Chip	GPIO21	GPIO22
MPU6886	SDA	SCL
AXP192	SDA	SCL
BM8563	SDA	SCL
FT6336U	SDA	SCL

ging current measured value

charging current	Fully charged current(Power OFF)	Fully charged current(Power ON)
0.219A	0.055A	0.147A

45Core2 M-BUS Schematic diagram

GND	ADC	G35	
GND	ADC	G36	
GND	RST	EN	
23	MOSI	DAC	G25
38	MISO	DAC	G26
18	SCK	3.3V	
G3	RXD0	TXD0	G1
13	RXD2	TXD2	G14
21	intSDA	intSCL	G22
22	DA_SDA	DA_SCL	G22

G15	PA_SDA	PA_SCL	G33
G27	GPIO	GPIO	G19
G2	I2S_DOUT	I2S_LRCK PDM_CLK	G0
	NC	PDM_DAT	G34
	NC	5V	
	NC	BAT	

15PORT EXPLAIN

PORT	PIN	Note:
PORT-A(Red)	32/33	I2C

SP32 ADC/DAC

ADC1	ADC2	DAC1	DAC2
8 channels	10 channels	2 channels	2 channels
G32-39	G0/2/4/12-15/25-27	G25	G26

For more information about Pin assignment and Pin Remapping, Please refer to [ESP32 Datasheet](#)

Related Link

Datasheet

- [ESP32](#)
- [FT6336U](#)
- [NS4168](#)
- [MPU6886](#)
- [ILI9342C](#)
- [SPM1423](#)
- [BM8563](#)
- [SY7088](#)
- [AXP192](#)
- [ATECC608A](#)

API

- [Arduino API](#)

Schematic

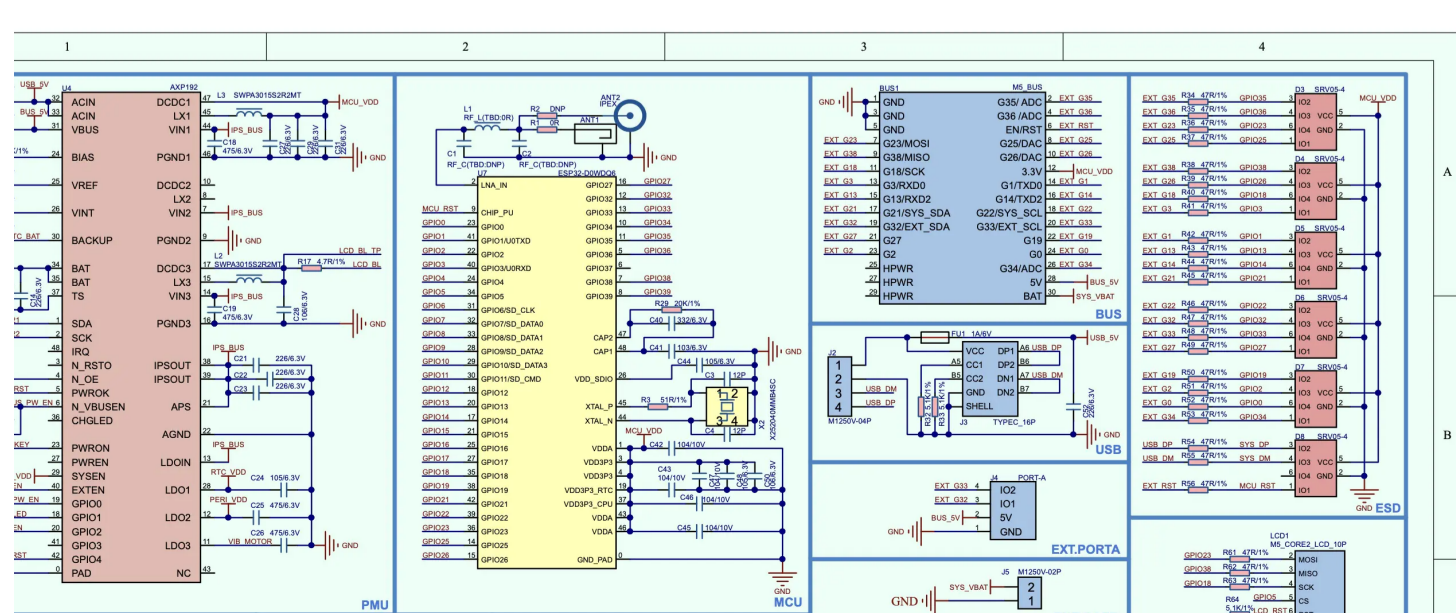

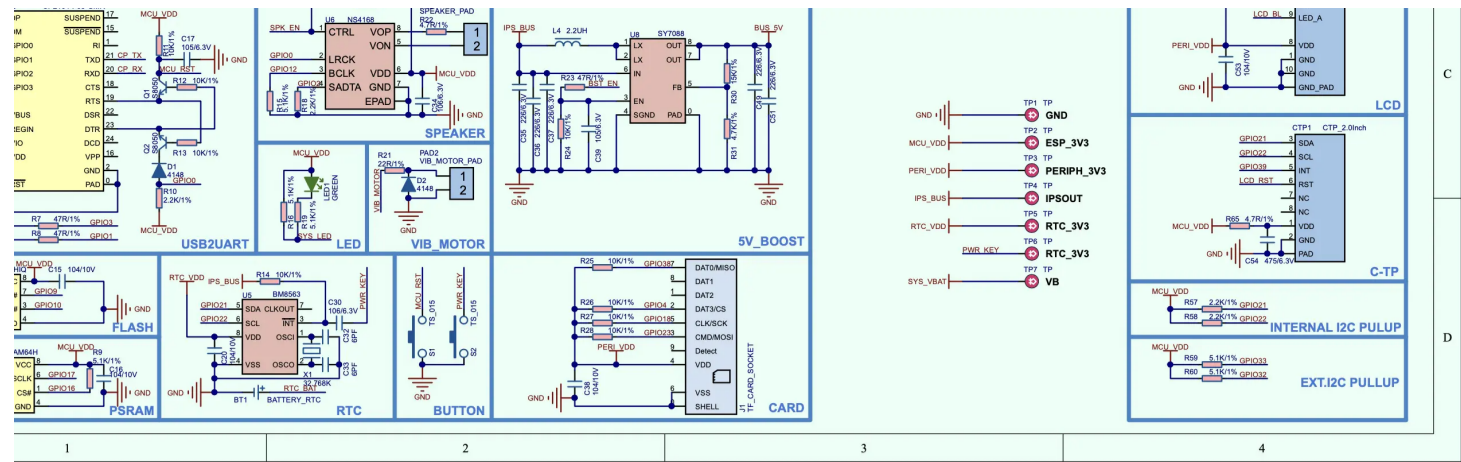

Core2-Schematic

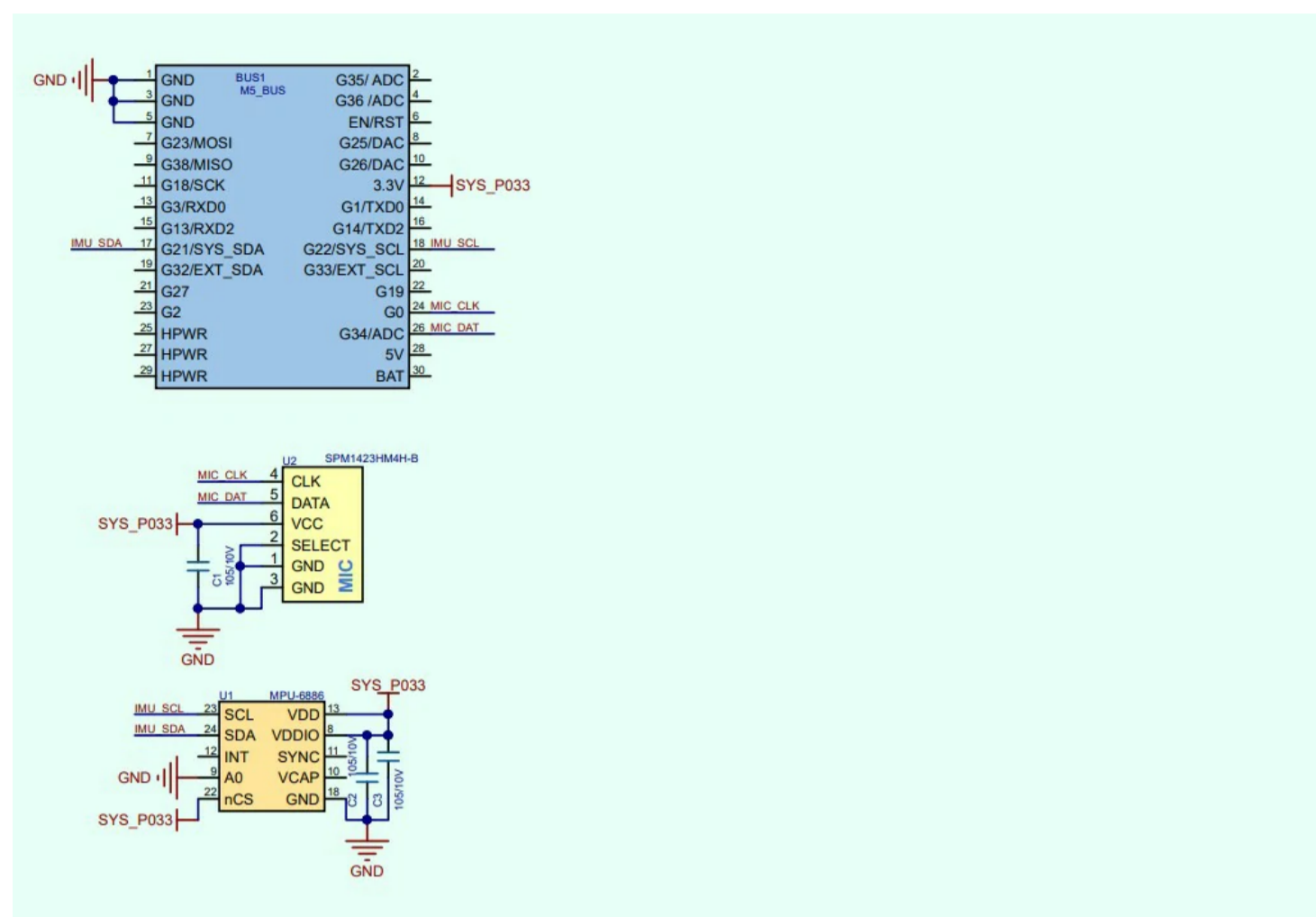

Core2 Expansion board-Schematic

Learn



Health monitor - Waylay IO

Health monitoring using the M5Stack Mini Heart Rate Unit and Non-Contact Infrared Thermometer Unit and the Waylay IO IoT platform.



One-Wheel Balancing Robot Using Reaction Wheels

I made one-wheel balancing robot. This robot can be operated remotely from a smartphone using Blynk.

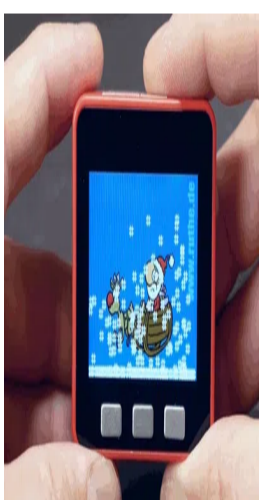

M5Stack Christmas Snow Globe

Modern times make modern solutions possible. Therefore, the step to a digital snow globe is not that far.

Example

Arduino

Click [here](#) to get Arduino code

Tutorial

JIFlow

Arduino

Version Change

Release Date

Product Change

Note:

2020.6	Initial public release<	/
2021.7	USB Chip changed from CP2104 to CH9102F	The actual delivery has two chip versions, CP2104/CH9102F, and there is no difference function and use