

May.1.2023 Copyright 2023 HIROSE ELECTRIC CO., LTD. All Rights Reserved.  
 In case of consideration for using Automotive equipment / device which demand high reliability, kindly contact our sales window correspondents.

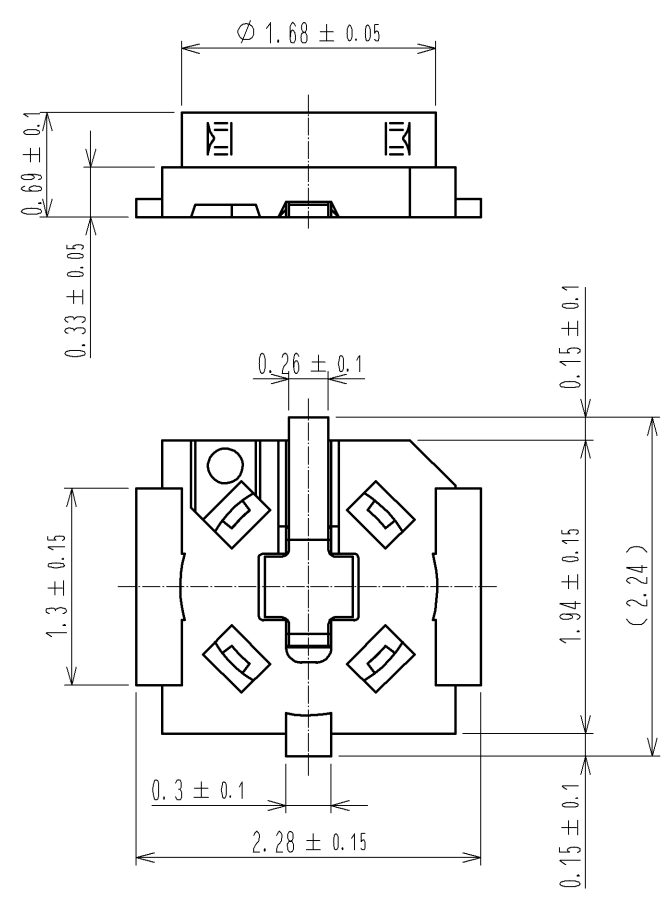

RECOMMENDED PC BOARD PATTERN DRAWING (5:1)

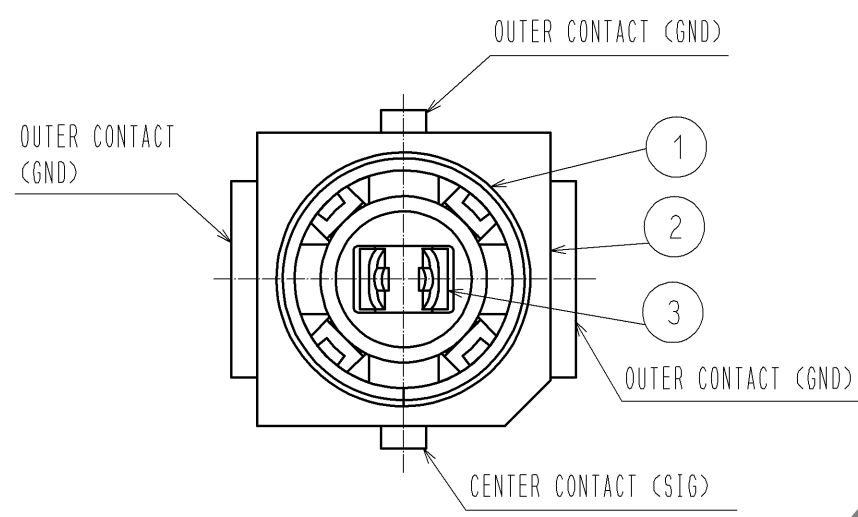
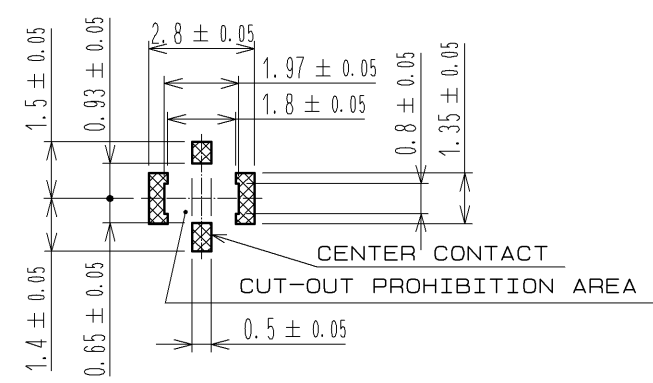

RECOMMENDED METAL MASK PATTERN DRAWING (5:1)

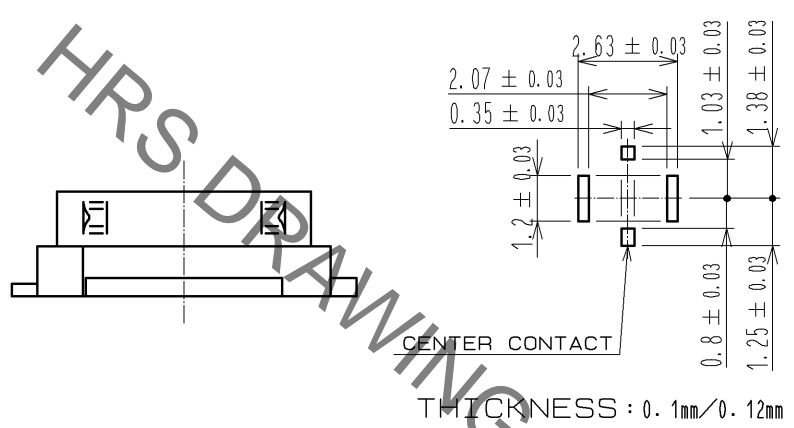

EMBOSSED TAPING DRAWING (4:1)

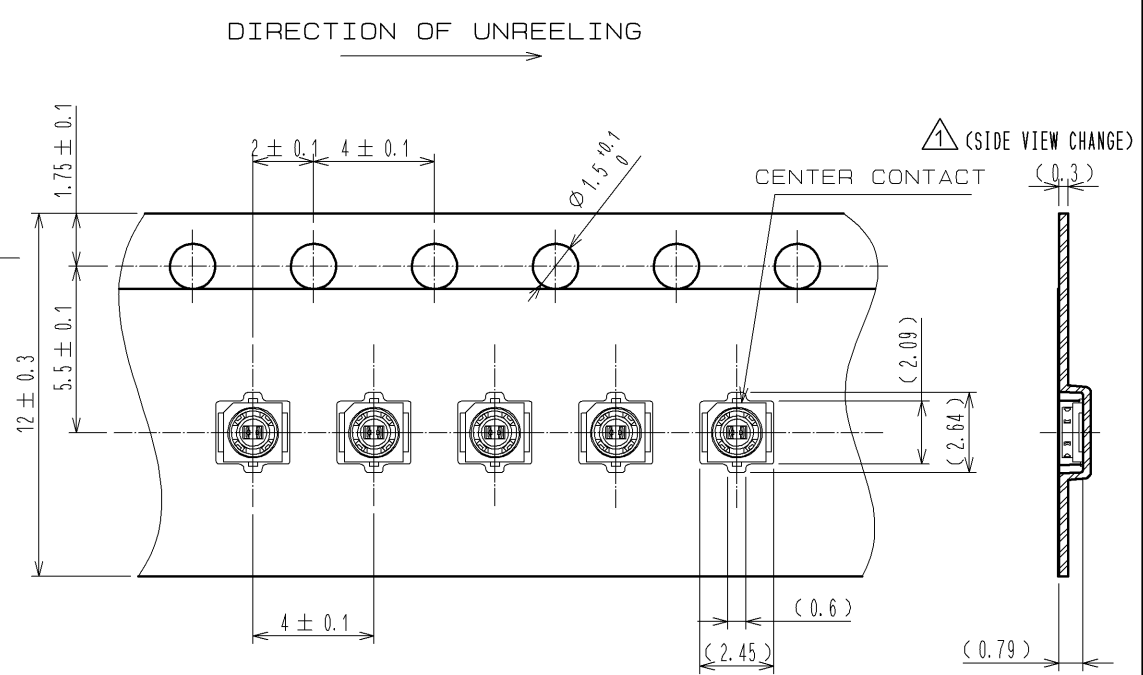

REEL DRAWING (SCALE FREE)

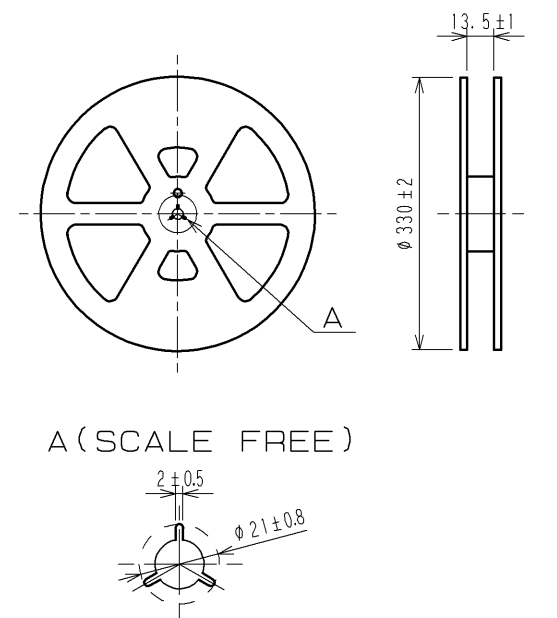

MOUNTING TEMPERATURE PROFILE (REFERENCE)

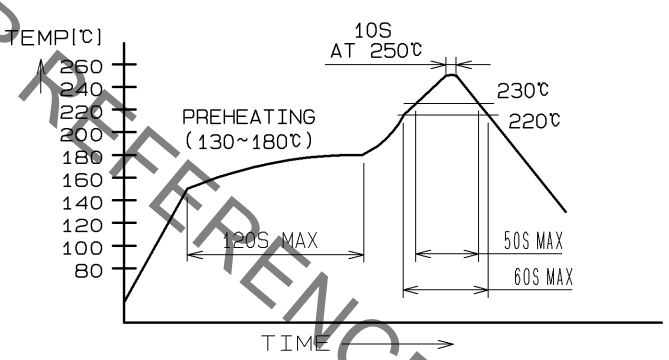

NOTE  
 MOUNTING TEMPERATURE PROFILE VARIES ACCORDING TO BOARD SIZE, SOLDER TYPE APPLIED AND SOLDER THICKNESS.  
 ·METAL MASK THICKNESS: 0.1mm / 0.12mm  
 ·Up to 2 cycles of Reflow.

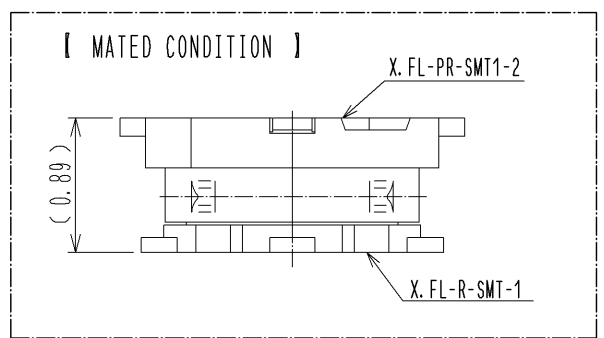
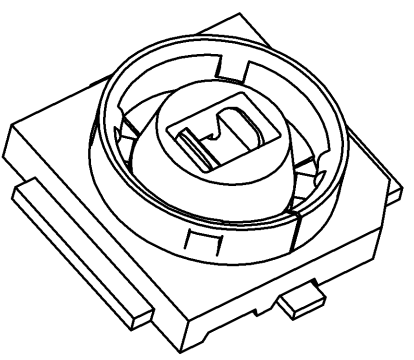

NOTES:

- 1: THE QUANTITY OF X.FL-PR-SMT1-2 IS 10000 CONNECTORS PER REEL.
- 2: LEAD CO-PLANARITY SHALL BE 0.08MAX.
- 3: FOR THE POSSIBILITY OF BREAKAGE OR DEFORMATION, DO NOT MATE THIS CONNECTOR WITH PARTNER, X.FL-R-SMT-1 BEFORE MOUNTING ON PC BOARD.

RoHS COMPLIANT, Halogen Free

2	LCP	(BLACK), UL94V-0	3	PHOSPHOR BRONZE	UNDER PLATING : NICKEL
1	PHOSPHOR BRONZE	UNDER PLATING : NICKEL OVER PLATING : SELECTIVE GOLD			OVER PLATING : SELECTIVE GOLD
NO.	MATERIAL	FINISH . REMARKS	NO.	MATERIAL	FINISH . REMARKS
UNITS mm		SCALE 20:1	COUNT 1	DESCRIPTION OF REVISIONS DIS-D-002899	DESIGNED TS. SAWAI
<b>HRS</b> HIROSE ELECTRIC CO., LTD.		APPROVED : MH. YAMANE	13.05.08	DRAWING NO.	EDC3-341481-80
		CHECKED : MH. TSUCHIDA	13.05.07	PART NO.	X.FL-PR-SMT1-2(80)
		DESIGNED : TS. SAWAI	13.04.23	CODE NO.	CL331-0713-7-80
		DRAWN : TS. SAWAI	13.04.23		
					DATE 13.05.24
					CHECKED MH. TSUCHIDA

May.1.2023 Copyright 2023 HIROSE ELECTRIC CO., LTD. All Rights Reserved.  
In case of consideration for using Automotive equipment / device which demand high reliability, kindly contact our sales window correspondents.

**■ MOUNTING PRECAUTIONS**

a. FPC MOUNTING

FPC must have suitable stiffener to prevent peeling of the solder joints during mating/ unmating. We recommend the FPC to be supported with the reinforcement.

b. MULTI-CONNECTOR PLACEMENT

When mounting on a solid PCB on both sides do not place more than one connector on each side. When mounting one side on a rigid PCB and other on the flexible printed circuit several connectors can be mounted on the rigid side. The FPC must have slots between each of the connectors to allow alignment with each corresponding connector.

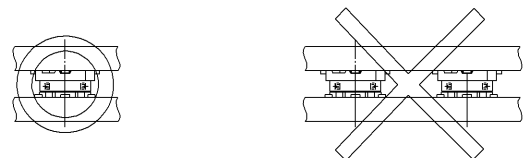

**■ UNMATING PRECAUTIONS**

Unmate by applying even vertical force to the mount plug (X.FL-PR-SMT1-2) as shown on fig. 4. Do not rock or lift by one side only. FPC must have suitable stiffener.



FIG. 4

**■ MATING PRECAUTIONS**

Connectors must be mated by hand only. Application of excessive forces may damage the connectors.

**● MATING PROCEDURES**

1) Align mount plug (X.FL-PR-SMT1-2) and receptacle (X.FL-R-SMT-1) by slight touch as shown on fig. 1.

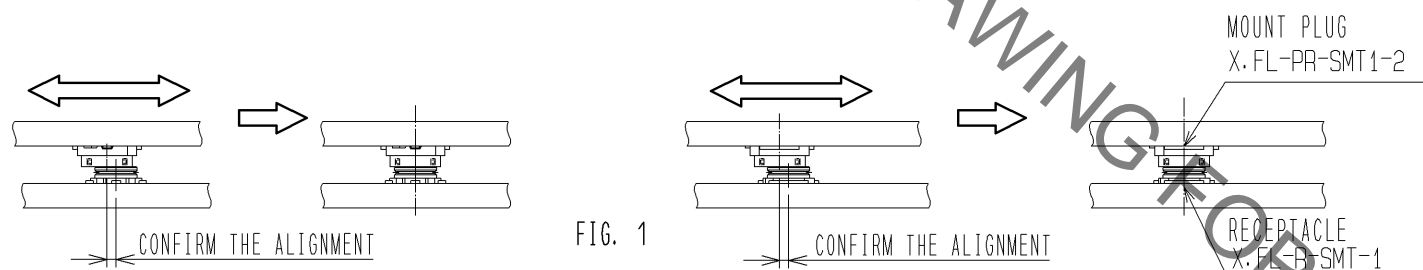

FIG. 1

2) Confirm the alignment by applying slight even pressure to the mount plug (X.FL-PR-SMT1-2) partially inserting it in the mount receptacle (X.FL-R-SMT-1), as shown in fig. 2. The plug should not move sideways or be slanted.

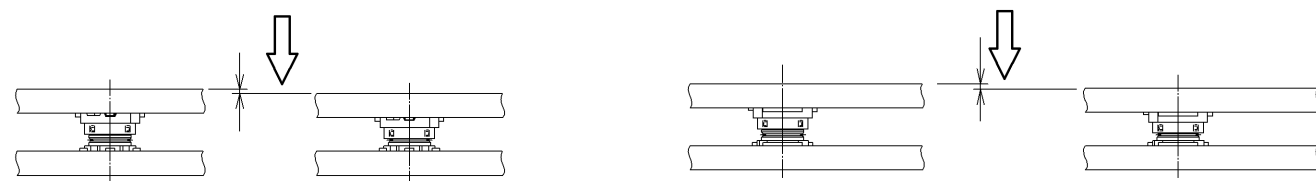

FIG. 2

3) Push-down on the mount plug (X.FL-PR-SMT1-2) until is fully inserted, confirming it with a tactile 'CLICK'.

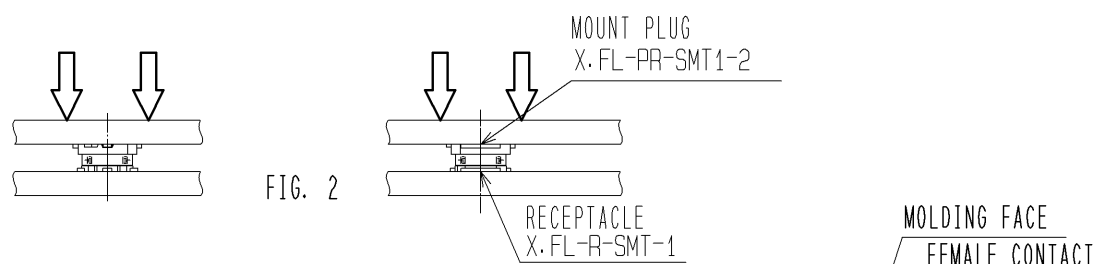

FIG. 2

4) When mating was not possible, please use it after confirming that a plug receptacle female contact by the transformation of the mold part does not have transformation before just using a plug receptacle.

If encountering some resistance during the unmating start lifting from side, as shown on fig. 5. Do not attempt unmating by lifting it from any of the other side.

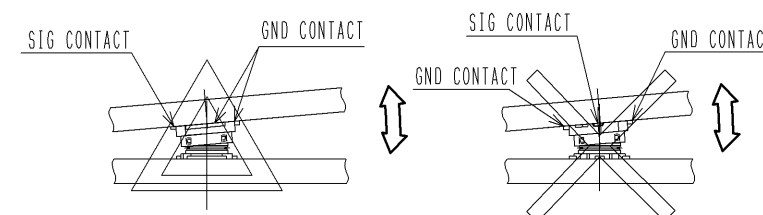

FIG. 5

**■ SUGGESTIONS TO PREVENT ACCIDENTAL UNMATING**

In environments where the connectors may encounter severe shock, vibration or FPC's bend spring-back it is advisable to provide additional support when connectors are fully mated. E.G. : device chassis or compressive cushion.



図番:	EDC3-341481-80
製品名:	X.FL-PR-SMT1-2<80>
製品コード:	CL331-0713-7-80

